



- Fixed Coaxial Attenuators
- Terminations & Loads
- Variable & Step Attenuators
- Power Dividers & Splitters
- Mechanical Phase Shifters
- DC Blocks
- Coaxial Adapters
- Connector Systems
 - PLANAR BLINDMATE®
 - PLANAR CROWN®
- Programmable Attenuators
- Subsystems & Accessories



**Microwave & RF
Components &
Subsystems**

Microwave & RF Components & Subsystems



Table of Contents

Aeroflex / Weinschel	2
Model Number Index	4-6
Product Index	6-8
Express & Argosy Sales	9-11
New Products	12-14
Fixed Coaxial Attenuators	15-80
Terminations & Loads	81-132
Variable Attenuators (Continuously & Step)	133-150
Power Splitters & Dividers	151-164
Phase Shifters	165-170
DC Blocks	171-176
Coaxial Adapters	177-184
Planar Blind-Mate® Connectors	185-192
Planar Crown® Connector System	193-198
Programmable Attenuators & Attenuator / Switch Controllers	199-260
Subsystems & Accessories	261-282
US Sales Representatives	283
Worldwide Sale Representatives	284
Ordering Information	285
Alphabetical Index	286-287
RoHs Compliance	287
Directions to Aeroflex / Weinschel	288

General Information

Each section of this catalog contains individual data sheets outlining product features, specifications, and outline drawings. These data sheets are preceded by a quick reference guide to help you select the product(s) that fits your needs. The page number for each is given in the quick reference guide.

NOTE: **EXPRESS** Shipment available via www.argosysales.com or 800-542-4457. Check with distributor for current products and stocking quantities.

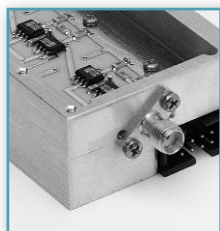



For over 60 years the name Weinschel has become synonymous with leadership in RF and microwave technologies and superior quality components and subsystems for wireless, defense, test and measurement, and

broadband markets throughout the world. Among its many technological achievements, Weinschel was the first to design and manufacture commercially available coaxial attenuators. Today, built upon a strong heritage, Aeroflex / Weinschel continues to provide a vast array of standard products together with custom-engineered solutions to satisfy demanding market needs for precision and high reliability coaxial components.

Aeroflex / Weinschel's product offering includes fixed attenuators for test, metrology and space applications; continuously variable, manual step, solid-state digital step and programmable step attenuators; high power terminations; resistive splitters and dividers; manual phase shifters; Planar Blind-Mate®, Planar Crown® connectors. In addition to coaxial components covering DC-50 GHz, Aeroflex / Weinschel offers a complete range of standard and custom-designed multi-path switching, combining, and attenuation subsystems for cable infrastructure and mobile wireless test applications, including RF simulation, multi-path and fading, high-power hot-switching attenuation, RF signal conditioning, RF and IF signal routing, and production testing.

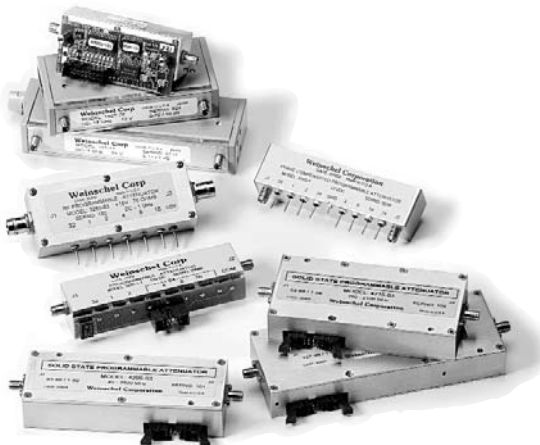

Aeroflex / Weinschel is fully dedicated to continuous improvement in all phases of its business (technical and administrative) through the application of TQM concepts and philosophies at every level. Our Quality Mission is to ensure that all products, services, and technical support are of the highest attainable level of quality.



Aeroflex / Weinschel's 35,000 square-foot facility in Frederick, MD houses more than 100 employees and is Certified to ISO 9001:2008 standards.

Attenuators & Terminations



From the company's very first DC - 1 GHz tee attenuator, came the technology that enabled the design of the first DC - 5 GHz, the first DC - 10 GHz, and the first DC - 18 GHz coaxial attenuators. These designs led to the development of the distributed resistor card attenuator element, which is the basis for most all attenuators

manufactured today from DC - 65 GHz. Until the original patents expired a few years ago, most major attenuator manufacturers in the U.S. were licensed under one or more Weinschel Engineering, Co., patents.

Today, our product line includes a wide variety of standard and custom designed fixed, continuously variable, manual step, and programmable binary step attenuators and terminations covering the DC to 50 GHz frequency range, at power levels up to 1,000 watts. Aeroflex / Weinschel is also a major supplier of HI-Rel MIL-3933 and Space qualified attenuators.

Connectors & Adapters



The superior performance Aeroflex / Weinschel components enjoy is due to our connector design capabilities. Utilizing proprietary design techniques, we offer connectorized devices that are mechanically robust, stable over environmental extremes, and highly reliable. We offer a comprehensive line of between-series adapters, blind-mate connectors, and our patented PLANAR CROWN® Connector System.

Our Planar Blind-mate Connector Series provides threadless connector mating which is useful when mating an array of connectors from one RF module to another in seconds with a “Forgiving” Mechanical Interface that permits a 0.02 Mis-Alignment. These connectors offer DC to 40 GHz operation, a contact life of 1.0 m cycles and a repeatability of 0.05 dB typical per connection. Other features of this connector series include pressurized and unpressurized designs, SMA and 2.92mm (SMK) connector options, space saving, and rugged construction.

Other Components

Aeroflex / Weinschel offers a comprehensive product line of Power Dividers, and Power Splitters. Many of these standard products were designed for particularly demanding broadband requirements, SWR, and high power system applications. As with the development of all Aeroflex / Weinschel products, high performance at competitive prices is of paramount importance.



Although Aeroflex / Weinschel’s product line contains a wide variety of standard components, a large number of our sales are custom products, that are mainly a result of adapting a standard or generic product to specific customer needs. This process provides our customers with reliable, high quality products at competitive prices to meet demanding technical and schedule requirements.

Subsystems

Aeroflex/Weinschel’s unique design approach provides the customer with a flexible, low cost solution for the operation and packaging of programmable step attenuators and other components such as amplifiers, power combines / dividers / splitters, switches, filters, etc.



Options can include standard controller interfaces (IEEE-488.1, RS-232, RS-422 Ethernet and others); multiple attenuation/switching schemes; individual to complex matrix/channel configurations; specialized testing and calibration; and customized packaging. These subsystems are ideal for use in specific test, simulation and emulation of cellular, wireless, mobile, defense, cable and telecommunication applications.



Aeroflex / Weinschel, Inc.
Aeroflex Microelectronic Solutions
 5305 Spectrum Drive, Frederick, MD 21742
 800-638-2048, 301-846-9222
 Fax: 301-846-9116
www.aeroflex.com/weinschel
weinschel-sales@aeroflex.com

This Index provides a complete Model/Part number listing of all products offered by Aeroflex / Weinschel within this catalog.

MODEL	DESCRIPTION	PAGE
AS-6	Calibrated Attenuator Set (N, dc-18 GHz)	.40
AS-18	Calibrated Attenuator Set (Precision N, dc-18 GHz)	.40
AS-20	Calibrated Attenuator Set (3.5mm, dc-26.5 GHz)	.40
RS3016	Subminiature Termination (SMA, 1 W, dc-18 GHz, Low Cost)	.90
1	Fixed Coaxial Attenuator (Type N, dc-12.4 GHz)	.36
1W	General Purpose Attenuator (Type N, dc-4 GHz, Low Cost)	.34
2	Fixed Coaxial Attenuator (Type N, dc-18 GHz)	.36
3M	Fixed Coaxial Attenuator (SMA, dc-12.4 GHz)	.27
3T	Fixed Coaxial Attenuator (Miniature SMA, dc-12.4 GHz)	.26
4H	Fixed Coaxial Attenuator (Hex, SMA, dc-18.6 GHz)	.29
4M	Fixed Coaxial Attenuator (SMA, dc-18 GHz)	.27
4T	Fixed Coaxial Attenuator (Miniature SMA, dc-18 GHz)	.26
23	Medium Power Fixed Coaxial Attenuator (N, 10 W, dc-18 GHz)	.47
24	Medium Power Fixed Coaxial Attenuator (N, SMK, 50 W, dc-8.5 GHz)	.55
32	High Reliability Fixed Coaxial Attenuator (SMA, dc-18 GHz)	.42
32J	High Reliability Fixed Coaxial Attenuator (SMK, dc-32 GHz)	.43
32K	High Reliability Fixed Coaxial Attenuator (SMK, dc-40 GHz)	.44
33	Medium Power Fixed Coaxial Attenuator (N, SMK, 25 W, dc-8.5 GHz)	.51
34	Medium Power Fixed Coaxial Attenuator (N, SMK, 25 W, dc-4 GHz)	.49
37	Medium Power Fixed Coaxial Attenuator (N, 10 W, dc-8.5 GHz)	.46
40	High Power Fixed Coaxial Attenuator (N, 150 W, dc-1.5 GHz)	.62
41	Medium Power Fixed Coaxial Attenuator (SMA, 10 W, dc-18 GHz)	.45
44	Lab Standard Fixed Coaxial Attenuator (N, dc-18 GHz)	.37
45	High Power Fixed Coaxial Attenuator (N, 250 W, dc-1.5 GHz)	.68
46	Medium Power Fixed Coaxial Attenuator (N, 3.5mm, 25 W, dc-18 GHz)	.52
47	Medium Power Fixed Coaxial Attenuator (N, 3.5mm, 50 W, dc-18 GHz)	.57
48	High Power Fixed Coaxial Attenuator (N, 3.5mm, 100 W, dc-18 GHz)	.61
49	High Power Fixed Coaxial Attenuator (N, SMK, 150 W, dc-8.5 GHz)	.65
53	High Power Fixed Coaxial Attenuator (N, 500 W, 2.5 GHz)	.70
54A	Fixed Coaxial Attenuator (SMK, dc-42 GHz)	.33
55	Fixed Coaxial Attenuator (TNC, dc-18 GHz)	.35
56	Fixed Coaxial Attenuator (3.5mm, dc-28 GHz)	.30
57	High Power Fixed Coaxial Attenuator (N, SMK, 150 W, dc-5.0 GHz)	.62
58	High Power Fixed Coaxial Attenuator (N, 250 W, dc-5.0 GHz)	.68
59	High Power Fixed Coaxial Attenuator (Conduction Cooled, N, SMK, 100 W, dc-2.5 GHz)	.76
65	High Power Fixed Coaxial Attenuator (N, SMK, 50 W, dc-2.5 GHz)	.63
66	High Power Fixed Coaxial Attenuator (N, 3.5mm, 150 W, dc-18 GHz)	.66
67	High Power Fixed Coaxial Attenuator (N, 350 W, dc-12.7 GHz)	.69
68	High Power Fixed Coaxial Attenuator (N, SMK, 100 W, dc-4 GHz)	.58
69A	Medium Power Fixed Coaxial Attenuator (SMA, 5 W, dc-18 GHz)	.38
72	Medium Power Fixed Coaxial Attenuator (Conduction Cooled, N, SMK, 50 W, dc-4 GHz)	.74
73	High Power Fixed Coaxial Attenuator (N, SMK, 100 W, dc-8.5 GHz)	.59
74	Medium Power Fixed Coaxial Attenuator (3.5mm, 25 W, dc-28 GHz)	.53
75A	Medium Power Fixed Coaxial Attenuator (SMK, 5 W, dc-40 GHz)	.39
77	Medium Power Fixed Coaxial Attenuator (7/16, 25 W, dc-6 GHz)	.50
78	Medium Power Fixed Coaxial Attenuator (7/16, 50 W, dc-6 GHz)	.54

MODEL	DESCRIPTION	PAGE
79	High Power Fixed Coaxial Attenuator (7/16, 150 W, dc-6 GHz)	.64
81	High Power Fixed Coaxial Attenuator (N, 500 W, dc-10 GHz)	.71
82	High Power Fixed Coaxial Attenuator (N, 1,000 W, dc-3 GHz)	.72
84A	Fixed Coaxial Attenuator (2.4mm, dc-40 GHz)	.32
86	Medium Power Fixed Coaxial Attenuator (Conduction Cooled, 3.5mm, 50 W, dc-22 GHz)	.75
87	High Reliability Fixed Coaxial Attenuators (SMK, dc-32 GHz)	.31
89	Medium Power Fixed Coaxial Attenuators (SMK, dc-40 GHz)	.48
90	Medium Power Fixed Coaxial Attenuators (N, 3.5mm, 50 W, dc-18 GHz)	.56
115A	Manual Step Attenuator (N, SMA, 0-9 dB, dc-4/18 GHz)	.146-148
116A	Manual Step Attenuator (N, SMA, 0-60 dB, dc-4/18 GHz)	.146-148
117A	Manual Step Attenuator (N, SMA, 0-69 dB, dc-4/18 GHz)	.146-148
118A	Manual Step Attenuator (N, SMA, 0-90 dB, dc-4/18 GHz)	.146-148
119A	Manual Step Attenuator (N, SMA, 0-99 dB, dc-4/18 GHz)	.146-148
150	Relay Switched Programmable Attenuator (3.5mm, dc-18 GHz)	.228-231
150T	SmartStep® Relay Switched Programmable Attenuator with built-in Microprocessor-Based Driver (3.5mm, dc-18 GHz)	.224-227
151	Relay Switched Programmable Attenuator (3.5mm, dc-4 GHz)	.228-231
151T	SmartStep® Relay Switched Programmable Attenuator with built-in Microprocessor-Based Driver (3.5mm, dc-4 GHz)	.224-227
152	Relay Switched Programmable Attenuator (3.5mm, dc-26.5 GHz)	.228-231
152T	SmartStep® Relay Switched Programmable Attenuator with built-in Microprocessor-Based Driver (3.5mm, dc-26.5 GHz)	.224-227
153	Relay Switched Programmable Attenuator (SMK, dc-40 GHz)	.233-234
251	High Power Fixed Coaxial Attenuator, Bi-directional (N, 200 W, dc-6 GHz)...New	.67
253	High Power Fixed Coaxial Attenuator (Conduction Cooled, N, SMK, 550 W, dc-6 GHz)...New	.80
257	High Power Fixed Coaxial Attenuator (Conduction Cooled, N, SMK, 250 W, dc-6 GHz)...New	.78
258	High Power Fixed Coaxial Attenuator (Conduction Cooled, N, SMK, 400 W, dc-6 GHz)...New	.79
260	High Power Fixed Coaxial Attenuators (N, SMK, 50 W, dc-18 GHz)...New	.60
268	High Power Fixed Coaxial Attenuator	.77
272N/S	High Reliability Attenuators (N, 5 W, dc-18 GHz)...New	.41
273N/S	High Reliability Attenuators (SMA, 2 W, dc-18 GHz)...New	.41
274N/S	High Reliability Attenuators (SMA, 2 W, dc-18 GHz)...New	.41
275	Medium Power Fixed Coaxial Attenuator (Conduction Cooled, SMK, 5 W, dc-40 GHz)...New	.73
276N/S	High Reliability Attenuators (N, 3.5mm, 25 W, dc-18 GHz)...New	.41
917	Miniature In-Line Phase Shifter (SMK, dc-20 GHz)	.169
940-60	Precision Continuously Variable Attenuator (N, SMA, dc-4 GHz)	.136-137
940-114	Precision Continuously Variable Attenuator (N, SMA, dc-2.0 GHz)	.136-137
940Z	Attenuator Stand	.136-137
980-X	Coaxial In-Line Phase Shifter (SMA, dc-3/7/12 GHz)	.167-168
980-XK	Coaxial In-Line Phase Shifter with Knob (SMA, dc-3/7/12 GHz)	.167-168
981	Coaxial Phase Shifters (3.5mm, dc-18 GHz)	.170
1404N	Precision Coaxial Termination (N, dc-18 GHz)	.91
1406A	Subminiature Coaxial Termination (SMA, dc-18 GHz)	.92
1408	Subminiature Coaxial Termination (SMA, dc-18 GHz)	.92
1418	Medium Power Coaxial Termination (N, 10 W, dc-18 GHz)	.103
1419	Medium Power Coaxial Termination (SMA, 10 W, dc-18 GHz)	.100
1424	Medium Power Coaxial Termination (N, 5 W, dc-12.4 GHz)	.97
1425	Medium Power Coaxial Termination (N, 10 W, dc-12.4 GHz)	.102
1426	High Power Coaxial Termination (N, SMK, 50 W, dc-8.5 GHz)	.111
1427	Medium Power Coaxial Termination (N, SMK, 25 W, dc-10 GHz)	.106
1428	High Power Coaxial Termination (N, SMK, 150 W, dc-1.5 GHz)	.119

Model Number Index



MODEL	DESCRIPTION	PAGE	MODEL	DESCRIPTION	PAGE
1429	Medium Power Coaxial Termination (N, 25 W, dc-18 GHz) . . .	107	1870A	Broadband Resistive Power Splitters (N, dc-18 GHz)	156
1430	Medium Power Coaxial Termination (N, 50 W, dc-18 GHz) . . .	112	3003	Manual Step Attenuator (SMA, 0-70 dB, dc-2.5 GHz) . . .	139-140
1431	High Power Coaxial Termination (N, 100 W, dc-18 GHz)	116	3006	Manual Step Attenuator (SMA, 0-100 dB, dc-1.25 GHz) .	139-140
1432	High Power Coaxial Termination (N, SMK, 150 W,	121	3007	Manual Step Attenuator (SMA, 0-10 dB, 2.5 GHz)	139-140
	dc-8.5 GHz)		3010	Manual Step Attenuator (SMA, 0-70 dB, 2.5 GHz)	139-140
1433	High Power Coaxial Termination (N, 250 W, dc-6 GHz)	122	3014	Manual Step Attenuator (SMA, 0-110 dB, dc-1.25 GHz) .	139-140
1434	High Power Coaxial Termination (N, 500 W, dc-2.5 GHz) . . .	123	3053	Manual Step Attenuator (SMA, 0-10 dB, dc-6 GHz) . . .	141-142
1435	High Power Coaxial Termination (N, SMK, 150 W, dc-6 GHz) .	119	3054	Manual Step Attenuator (SMA, 0-70 dB, dc-6 GHz) . . .	141-142
1437RA	Subminiature Coaxial Termination (SMA, 2 W, dc-6 GHz)	90	3056	RF Manual Step Attenuator (SMA, 0-70 dB,	138
1439	High Power Coaxial Termination (N, SMK, 150 W,	118		dc-3 GHz)..NEW	
	dc-2.5 GHz)		3200-XE	Programmable Attenuators with optional TTL	209-214
1440	Medium Power Coaxial Termination (N, SMK, 100 W,	114		Interface (SMA, 8-cell, dc-3 GHz)	
	dc-6 GHz)		3200T-XE	SmartStep® Programmable Attenuators with built-in . . .	215-217
1441	Medium Power Coaxial Termination (Conduction Cooled, . . .	126		Microprocessor-Based Driver (SMA, 8-cell, dc-3 GHz)	
	N, SMK, 50 W, dc-4 GHz)		3201-XE	Programmable Attenuators with optional TTL	209-214
1442	Medium Power Coaxial Termination	115		Interface (SMA, 5-cell, dc-3 GHz)	
	(N, SMK, 100 W, dc-8.5 GHz)		3201T-XE	SmartStep® Programmable Attenuators with built-in . . .	215-217
1443A	Medium Power Coaxial Termination (SMA, 5 W, dc-18 GHz) . .	98		Microprocessor-Based Driver (SMA, 5-cell, dc-3 GHz)	
1444	Medium Power Termination (3.5mm, 25 W, dc-26.5 GHz) . . .	108	3205-XE	Programmable Attenuators with optional TTL	209-214
1445A	Medium Power Coaxial Termination (SMK, 5 W,	99		Interface (SMA, 4-cell, dc-3 GHz)	
	dc-40 GHz)		3205T-XE	SmartStep® Programmable Attenuators with built-in . . .	215-217
1446	Medium Power Coaxial Termination (7/16, 25 W, dc-6 GHz) . .	105		Microprocessor-Based Driver (SMA, 4-cell, dc-3 GHz)	
1447	Medium Power Coaxial Termination (7/16, 50 W, dc-6 GHz) . .	110	3206-1E	Programmable Attenuators with optional TTL	209-214
1448	High Power Coaxial Termination (7/16, 150 W, dc-6 GHz) . .	120		Interface (SMA, 6-cell, dc-3 GHz)	
1452	Medium Power Coaxial Termination (N, SMK, 25 W,	104	3206T-1E	SmartStep® Programmable Attenuators with built-in . . .	215-217
	dc-4 GHz)			Microprocessor-Based Driver (SMA, 6-cell, dc-3 GHz)	
1453	Medium Power Coaxial Termination (N, 10 W, dc-8.5 GHz) . .	101	3209-1E	Programmable Step Attenuators with optional TTL . . .	209-214
1455	General Purpose Coaxial Termination (N, 18 GHz)	93		Interface (SMA, 10-cell, dc-3 GHz)	
1456	High Power Coaxial Termination (N, 1,000 W, dc-3 GHz) . . .	124	3209T-1E	SmartStep® Programmable Attenuators with built-in . . .	215-217
1458	Medium Power Coaxial Termination (3.5mm, 50 W,	127		Microprocessor-Based Driver (SMA, 10-cell, dc-2 GHz)	
	dc-22 GHz)		3404-XX	Programmable Attenuators with optional TTL Interface .	218-221
1459	Precision Coaxial Termination (SMK, dc-40 GHz)	95		(SMA, 4-cell, dc-6 GHz)..New	
1460	Precision Coaxial Termination (2.4mm, dc-50 GHz)	96	3406-XX	Programmable Attenuators with optional TTL Interface .	218-221
1465	Precision Coaxial Termination (3.5mm, dc-32 GHz)	94		(SMA, 6-cell, dc-6 GHz)	
1467	Medium Power Coaxial Termination (3.5mm, N,	113	3408-XX	Programmable Attenuators with optional TTL Interface .	218-221
	dc-20 GHz, 50 W)			(SMA, 6-cell, dc-6 GHz)	
1468	Medium Power Coaxial Termination(BNC, SMA, N,	109	3404T-XX	SmartStep® Programmable Attenuators with built-in . . .	222-223
	dc-6 GHz, 50 W)..New			Microprocessor-Based Driver (SMA, 6-cell,	
1469	High Power Coaxial Termination (N, 3.5mm, 100 W,	117		dc-6 GHz)..New	
	dc-20 GHz)..New		3406T-XX	SmartStep® Programmable Attenuators with built-in . . .	222-223
1470	High Power Coaxial Termination (Conduction Cooled, N, . . .	128		Microprocessor-Based Driver (SMA, 6-cell,	
	SMK, 100 W, dc-6 GHz)..New			dc-6 GHz)	
1471	High Power Coaxial Termination (Conduction Cooled, N, . . .	129	3408T-XX	SmartStep® Programmable Attenuators with built-in . . .	222-223
	SMK, 250 W, dc-6 GHz)..New			Microprocessor-Based Driver (SMA, 8-cell,	
1472	High Power Coaxial Termination (Conduction Cooled, N, . . .	130		dc-6 GHz)..New	
	SMK, 400 W, dc-6 GHz)..New		3330A	General Purpose Attenuator (Round body, SMA, 2 W,	28
1473	High Power Coaxial Termination (Conduction Cooled, N, . . .	131		dc-18 GHz)	
	SMK, 100 W, dc-6 GHz)..New		3331A	General Purpose Attenuator (Hex body, SMA, 2 W,	28
1474	Coaxial Termination (Conduction Cooled, SMK, 550 W,	125		dc-18 GHz)	
	dc-40 GHz)..New		4202-XX	Digital Attenuators with TTL Driver	235-236
1506A	Broadband Resistive Power Divider (N, dc-18 GHz)	161		(SMA, 0.4-6.0 GHz, 1 W)..New	
1507R	Broadband Resistive Power Splitter (Matching, SMA,	154	4203-XX	Digital Attenuators with TTL Driver	237-238
	dc-4 GHz, Low Cost)			(SMA, 0.2-6.0 GHz, 1 W)..New	
1513	Precision Coaxial Adapters (N to N, dc-18 GHz)	182	4205-XX	Digital Attenuators with TTL & USB Driver	239-240
1515	Broadband Miniature Resistive Power Divider	160		(SMA, 0.2-6.0 GHz, 1 W)..New	
	(SMA, dc-18 GHz)		4226-XX	Pin Switched Solid-State Programmable Attenuators . . .	241-242
1515-1	Broadband Miniature Resistive Power Divider	160		(SMA, 0.8-2.5/3.0 GHz, 1 W, 6-cell)..New	
	(SMA, dc-18 GHz)		4228-XX	Pin Switched Programmable Attenuators	241-242
1534	Broadband Resistive Power Splitter (Matching, SMK,	158		(SMA, 2.5/.3 GHz, 1 W, 8-cell)..New	
	dc-40 GHz)		4238-XX	GaAs Switched Programmable Attenuator	243-244
1548	Precision Coaxial Adapter (N to SMA, 18 GHz)	184		(SMA, 10 MHz-2.5 GHz, 1 W, 8-cell)	
1549R	Broadband Resistive Power Divider (SMA, Low Cost	159	4246-XX	Phase Compensated GaAs Switched Programmable . . .	245-246
	dc-4 GHz)			Attenuators (SMA, 10 MHz-2.5 GHz, 4 W, 6-cell)	
1550A	4-Way Resistive Power Dividers (SMA, dc-3 GHz)	164	4248-XX	Phase Compensated GaAs Switched Programmable . . .	245-246
1568	Precision Coaxial Panel Adapter (SMA, dc-26.5 GHz)	180		Attenuators (SMA, 10 MHz-2.5 GHz, 4 W, 8-cell)	
1568-1	Precision Coaxial Panel Adapter (SMA, dc-26.5 GHz)	180	4258	Digitally Controlled Variable PIN Attenuator	247
1575	Broadband Resistive Power Divider (SMK, dc-40 GHz)	163		with TTL Driver..New	
1579	Broadband Resistive Power Splitter (3.5mm, dc-26.5 GHz) .	155	7002	High Performance Coaxial Adapter (SMA to N, dc-18 GHz) .	183
1580	Broadband Resistive Power Divider (3.5mm, dc-26.5 GHz) .	162	7003	Inside DC Block (N, dc-18 GHz)	172
1580-1	Broadband Resistive Power Divider (3.5mm, dc-26.5 GHz) .	162	7004A	PLANAR CROWN® Universal Connector System	195-198
1587	Precision Coaxial Adapter (SMA to SMA, dc-26.5 GHz) . . .	181		(SMK Bulkhead, dc-18 GHz)	
1588	Precision Coaxial Adapter (SMA to SMA, dc-26.5 GHz) . . .	181	7005A	PLANAR CROWN® Universal Connector System	195-198
1589	Precision Coaxial Adapter (SMA to SMA, dc-26.5 GHz) . . .	181		(Crowns)	
1591	Open / Load / Short (TNC, dc-2 GHz)	132	7006	Inside DC Block (SMA, 9 kHz-26.5 GHz)	173
1593	Broadband Resistive Power Splitter (Matching, 3.5mm,	157	7006-1	Inside DC Block (SMA, 9 kHz-20 GHz)	174
	dc-26.5 GHz)		7008	SMA Planar Blindmate® Connector (Pressurized, 40 GHz) .	188
1594	4-Way Resistive Power Dividers (3.5mm, dc-18 GHz)	164	7010-1, -2	PLANAR BULKHEAD with DC Block (10 MHz-26.5 GHz) . .	175

MODEL	DESCRIPTION	PAGE
7012	Inside/Outside DC Block (500 MHz-8.6 GHz)	176
7034	Rear Locking Planar Blindmate® Connector (Floating)	189
7034-1	Rear Locking Planar Blindmate® Connector (Fixed)	189
7035	Front Locking Planar Blindmate® Connector (Floating)	190
7035-1	Front Locking Planar Blindmate® Connector (Fixed)	190
7035R	Front Locking Planar Blindmate® Connector (Floating)	190
7035R-1	Front Locking Planar Blindmate® Connector (Fixed)	190
7041	Rear Locking Planar Blindmate® Connector (Floating, Lower Cost Design)	191
8210A-1	SmartStep® Programmable Attenuator/Switch Controller (IEEE-488)	258-260
8210A-2	SmartStep® Programmable Attenuator/Switch Controller (RS232/RS422/RS485)	258-260
8304-5	RF Switching Subsystem	273-275
8310	SmartStep® Programmable Attenuator Unit	248-251
8311	SmartStep® Programmable Attenuator Unit, 6 Channel	248-251
8312	SmartStep® High Power Programmable Attenuator (100 W, Hot switching)	255-257
8314	SmartStep® WLAN Roaming Simulator	265-266
8331	Programmable Attenuator Unit with Ethernet & RS232 ...preliminary data sheet	252-254

MODEL	DESCRIPTION	PAGE
8390	Amplifier / Switch Unit (3.4 -4.2 GHz)	269-270
8390-1	Amplifier / Switch Unit (0.95-13 GHz)	269-270
8501	SmartStep® High Power Programmable Switch (100 W, Hot Switching)	271-272
9003	Manual Step Attenuator (0-69 dB, SMA, 2 W, dc-4/18 GHz)	143-145
9004	Manual Step Attenuator (0-99 dB, SMA, 2 W, dc-4/18 GHz)	143-145
9009	Manual Step Attenuator (0-9 dB, SMA, 2 W, dc-4/18 GHz)	143-145
9010	Manual Step Attenuator (0-60 dB, SMA, 2 W, dc-4/18 GHz)	143-145
9011	Manual Step Attenuator (0-90 dB, SMA, 2 W, dc-4/18 GHz)	143-145
9012-9	Manual Step Attenuator (0-9 dB, 26.5 GHz, SMK)	149-150
9012-70	Manual Step Attenuator (0-70 dB, 26.5 GHz, SMK)	149-150
10044	Programmable Attenuator/Switch Unit with Ethernet (10/100 BaseT) Control...New	267-268
10077	L-Band 8 X 8 Switch Matrix with Ethernet Control (10/100 BaseT)...New	276-277

Product Index

This Index provides a complete page by page listing of all products and services offered by Aeroflex / Weinschel.

DESCRIPTION	PAGE
FIXED ATTENUATORS	15-80
General Information	15
Quick Reference Guide, Low Power (DC-42 GHz, 1-5 Watts)	16
Quick Reference Guide, Hi-Reliability & Space (DC-40 GHz, 2 Watts)	16
Quick Reference Guide, Medium Power (DC-40 GHz, 10-50 Watts)	17
Quick Reference Guide, High Power (DC-18 GHz, 100-1,000 Watts)	18
Quick Reference Guide, Low IMD (dc-18 GHz, 25-500 Watts)	19
Quick Reference Guide, Conduction Cooled (dc-40 GHz, 5-550 Watts)	20
Frequently Asked Questions	21-22
Attenuator Selection Guide	23
Article: Understanding Temperature & Power Coefficient in Attenuators	24-25
Low Power (1-5 W, DC-40 GHz)	26-39
SMA Fixed Coaxial Attenuator (Models 3T & 4T)	26
SMA Fixed Coaxial Attenuator (Models 3M & 4M)	27
Low Cost SMA Fixed Coaxial Attenuator (Models 3330A/3331A)	28
Hex Body Attenuator (Model 4H)	29
3.5mm Fixed Coaxial Attenuator (Model 56)	30
SMK Fixed Coaxial Attenuators (Model 87)	31
2.4mm Fixed Coaxial Attenuator (Model 84A)	32
SMK Fixed Coaxial Attenuator (Model 54A)	33
Type N General Purpose Attenuator (Model 1W)	34
TNC Fixed Coaxial Attenuator (Models 55)	35
Coaxial Fixed Attenuator (Models 1 & 2)	36
Lab Standard Coaxial Attenuator (Model 44)	37
SMA Fixed Coaxial Attenuator (Model 69A)	38
SMK Fixed Coaxial Attenuator (Model 75A)	39
Calibrated Attenuator Sets (AS-6, AS-18, AS-20)	40
High Reliability & Space (2-25 W, dc-40 GHz)	41-44
High Reliability Attenuators (Models 272N/S, 273N/S, 274N/S, 276N/S)...New	41
High Reliability Fixed Coaxial Attenuators (Model 32)	42
SMK High Reliability Fixed Coaxial Attenuators (Model 32J)	43
SMK High Reliability Fixed Coaxial Attenuators (Model 32K)...New	44

DESCRIPTION	PAGE
Medium Power (10 – 50 Watts)	45-57
Medium Power Fixed Coaxial Attenuator (Model 41)	45
Medium Power Fixed Coaxial Attenuator (Model 37)	46
Medium Power Fixed Coaxial Attenuator (Model 23)	47
Medium Power Fixed Coaxial Attenuator (Model 89)	48
Medium Power Fixed Coaxial Attenuator (Model 34)	49
Medium Power Fixed Coaxial Attenuator (Model 77)	50
Medium Power Fixed Coaxial Attenuator (Model 33)	51
Medium Power Fixed Coaxial Attenuator (Model 46)	52
Medium Power Fixed Coaxial Attenuator (Model 74)	53
High Power Fixed Coaxial Attenuator (Model 78)	54
Medium Power Fixed Coaxial Attenuator (Model 24)	55
Medium Power Fixed Coaxial Attenuator (Model 90)	56
Medium Power Fixed Coaxial Attenuator (Model 47)	57
High Power (100-1,000 W)	58-72
High Power Fixed Coaxial Attenuator (Model 68)	58
High Power Fixed Coaxial Attenuator (Model 73)	59
High Power Fixed Coaxial Attenuator (Model 260) ...New	60
High Power Fixed Coaxial Attenuator (Model 48)	61
High Power Fixed Coaxial Attenuators (Model 40 & 57)	62
High Power Fixed Coaxial Attenuator (Model 65)	63
High Power Fixed Coaxial Attenuator (Model 79)	64
High Power Fixed Coaxial Attenuator (Model 49)	65
High Power Fixed Coaxial Attenuator (Model 66)	66
High Power Fixed Coaxial Attenuator (Model 251)...New	67
High Power Fixed Coaxial Attenuator (Model 45 & 58)	68
High Power Fixed Coaxial Attenuator (Model 67)	69
High Power Fixed Coaxial Attenuator (Model 53)	70
High Power Fixed Coaxial Attenuator (Model 81)	71
High Power Fixed Coaxial Attenuator (Model 82)	72
Conduction Cooled (Flat Packs)	73-80
Conduction Cooled Coaxial Attenuator (Model 275)...New	73
Conduction Cooled Fixed Coaxial Attenuator (Model 72)	74
Conduction Cooled Fixed Coaxial Attenuator (Model 86)	75
Conduction Cooled Fixed Coaxial Attenuator (Model 59)	76
Conduction Cooled Fixed Coaxial Attenuator (Model 268) ...New	77
Conduction Cooled Fixed Coaxial Attenuator (Model 257)...New	78
Conduction Cooled Coaxial Attenuator (Model 258)...New	79
Conduction Cooled Coaxial Attenuator (Model 253)...New	80
Low IMD Attenuators	50-80
Medium Power Fixed Coaxial Attenuator (Model 33-XX-XX-LIM)	51

<u>DESCRIPTION</u>	<u>PAGE</u>
Medium Power Fixed Coaxial Attenuator (Model 46-XX-XX-LIM)	52
Medium Power Fixed Coaxial Attenuator (Model 24-XX-XX-LIM)	55
Medium Power Fixed Coaxial Attenuator (Model 90-XX-XX-LIM)	56
High Power Fixed Coaxial Attenuators (Model 260-XX-XX-LIM)	60
High Power Fixed Coaxial Attenuators (Model 57-XX-XX-LIM)	62
High Power Fixed Coaxial Attenuators (Model 79-XX-XX)	64
High Power Fixed Coaxial Attenuator (Model 49-XX-XX-LIM)	65
High Power Fixed Coaxial Attenuator (Model 58-XX-XX-LIM)	68
High Power Fixed Coaxial Attenuator (Model 53-XX-XX-LIM)	70
Conduction Cooled Fixed Coaxial Attenuator (Model 268-XX-XX-LIM) ...New	77
Conduction Cooled Fixed Coaxial Attenuator (Model 257 XX-XX-LIM)...New	78
Conduction Cooled Coaxial Attenuator (Model 258 XX-XX-LIM)...New	79
Conduction Cooled Coaxial Attenuator (Model 253 XX-XX-LIM)... ..	80
TERMINATIONS & LOADS	81-132
General Information	81
Quick Reference Guide (dc-50 GHz, 1-5 W)	82
Quick Reference Guide (dc-26.5 GHz, 10-50 W)	83
Quick Reference Guide (dc-18 GHz, 100-1000 W)	84
Low IM Terminations (dc-20 GHz, 25-550 W)	85
Conduction Cooled Termination & Load Reference Guide	86
Termination Selection Guide	87
Frequently Asked Questions	88-89
Low Power (1-5 W, DC-40 GHz)	90-99
SMA Subminiature Coaxial Termination (Models 1437R & RS3016)	90
Precision Coaxial Termination (Model 1404N)	91
Subminiature Coaxial Termination (Model 1406A & 1408)	92
General Purpose Coaxial Termination (Model 1455)	93
Subminiature Coaxial Termination (Model 1465/A)	94
Subminiature Coaxial Termination (Model 1459/A)	95
Subminiature Coaxial Termination (Model 1460/A)	96
Coaxial Termination (Model 1424)	97
Coaxial Termination (Model 1443A)	98
Coaxial Termination (Model 1445A)	99
Medium Power (10 – 50 Watts)	100-113
Medium Power Coaxial Termination (Model 1419)	100
Medium Power Coaxial Termination (Model 1453)	101
Medium Power Coaxial Termination (Model 1425)	102
Medium Power Coaxial Termination (Model 1418)	103
Medium Power Coaxial Termination (Model 1452)	104
Medium Power Coaxial Termination (Model 1446)	105
Medium Power Coaxial Termination (Model 1427)	106
Medium Power Coaxial Termination (Model 1429)	107
Medium Power Coaxial Termination (Model 1444)	108
Medium Power Coaxial Termination (Model 1468)...New	109
Medium Power Coaxial Termination (Model 1447)	110
Medium Power Coaxial Termination (Model 1426)	111
Medium Power Coaxial Termination (Model 1430)	112
Low Cost Medium Power Coaxial Termination (Model 1467) ...New	113
High Power (100-1,000 W)	114-124
High Power Coaxial Termination (Model 1440)	114
High Power Coaxial Termination (Model 1442)	115
High Power Coaxial Termination (Model 1431)	116
High Power Coaxial Termination (Model 1469) ...New	117
High Power Coaxial Termination (Model 1439)	118
High Power Coaxial Termination (Model 1428 & 1435)	119
High Power Coaxial Termination (Model 1448)	120
High Power Coaxial Termination (Model 1432)	121
High Power Coaxial Termination (Model 1433)	122

<u>DESCRIPTION</u>	<u>PAGE</u>
High Power Coaxial Termination (Model 1434)	123
High Power Coaxial Termination (Model 1456)	124
Conduction Cooled (All Flat Packs)	154-130
Conduction Cooled Coaxial Termination (Model 1474)	125
Conduction Cooled Coaxial Termination (Model 1441)	126
Conduction Cooled Coaxial Termination (Models 1458)	127
Conduction Cooled Coaxial Termination (Model 1470) ...New	128
Conduction Cooled Coaxial Termination (Model 1471) ...New	129
Conduction Cooled Coaxial Termination (Model 1472) ...New	130
Conduction Cooled Coaxial Termination (Model 1473) ...New	131
Open / Load / Shorts	132
Open / Short / Load (Model 1591) ...New	132
Low IMD Terminations	111-131
Medium Power Coaxial Termination (Model 1426-X-LIM)	111
Medium Power Coaxial Termination (Model 1427-X-LIM)	106
Medium Power Coaxial Termination (Model 1429-X-LIM)	107
Medium Power Coaxial Termination (Model 1430-X-LIM)	112
High Power Coaxial Termination (Model 1431-X-LIM)	116
High Power Coaxial Termination (Model 1467-X-LIM) ...New	112
High Power Coaxial Termination (Model 1469-X-LIM) ...New	117
High Power Coaxial Termination (Model 1435-X-LIM)	119
High Power Coaxial Termination (Model 1432-X-LIM)	121
High Power Coaxial Termination (Model 1433-X-LIM)	122
High Power Coaxial Termination (Model 1434-X-LIM)	123
Conduction Cooled Coaxial Termination (Model 1470-X-LIM) ...New	128
Conduction Cooled Coaxial Termination (Model 1471-X-LIM) ...New	129
Conduction Cooled Coaxial Termination (Model 1472-X-LIM) ...New	130
Conduction Cooled Coaxial Termination (Model 1473-X-LIM) ...New	131
VARIABLE & MANUAL STEP ATTENUATORS	133-150
General Information	133
Quick Reference Guide (Continuously Variable)	134
Quick Reference Guide (Manual Step)	134
Frequently Asked Questions	135
Precision Continuously Variable Attenuator (Model 940-60 & 940-114)	136-137
Manual Step Attenuators (Models 3003, 3006, 3007, 3010, 3014)	138-139
RF Manual Step Attenuators (Model 3056)...New	140
Manual Step Attenuators (Models 3053 & 3054)	141-142
Manual Step Attenuator (Models 9003, 9004, 9009, 9010 & 9011)	143-145
Manual Step Attenuators (Models 115A through 119A)	146-148
Manual Step Attenuators (Models 9012)	149-150
POWER SPLITTERS & DIVIDERS	151-162
General Information	151
Quick Reference Guide (Resistive Power Splitters)	152
Quick Reference Guide (Resistive Power Dividers)	152
Quick Reference Guide (Open / Short / Load) ...New	152
Frequently Asked Questions	153
Broadband Resistive Power Splitter (Model 1507R)	154
Broadband Resistive Power Splitter (Model 1579)	155
Broadband Resistive Power Splitter (Model 1870A)	156
Broadband Resistive Power Splitter (Model 1593)	157
Broadband Resistive Power Splitter (Model 1534)	158
Low Cost Broadband Miniature Resistive Power Divider (Model 1549R)	159
Broadband Miniature Resistive Power Divider (Models 1515 & 1515-1)	160
Broadband Miniature Resistive Power Divider (Model 1506A)	161
Broadband Miniature Resistive Power Divider (Models 1580 & 1580-1)	162
Broadband Miniature Resistive Power Divider (Model 1575)	163

<u>DESCRIPTION</u>	<u>PAGE</u>
4-Way Resistive Power Dividers (Models 1550A)	164
4-Way Resistive Power Dividers (Models 1594)	164
MECHANICAL PHASE SHIFTERS	165-170
General Information	165
Quick Reference Guide	166
Phase Shifters (Model 980)	167-168
Miniature In-Line Phase Shifter (Model 917)	169
Coaxial Phase Shifter (Model 981)	170
DC BLOCKS	171- 176
General Information	171
Quick Reference Guide	171
Inside dc Block (Models 7003)	172
Inside dc Block (Models 7006)	173
Inside dc Block (Models 7006-1)	174
PLANAR BULKHEAD with Inside dc Block (Model 7010)	175
Inside/Outside dc Block (Model 7012)	176
COAXIAL ADAPTERS	177
General Information	177
Quick Reference Guide	178
Frequently Asked Questions	179
OEM Precision Coaxial Panel Adapters (Models 1568	180
& 1568-1)	
Precision Coaxial Adapter (Models 1587, 1588, 1589)	181
Precision Coaxial Adapter (Model 1513)	182
High Performance Coaxial Adapter (Model 7002)	183
Precision Coaxial Adapter (Model 1548)	184
Planar Blindmate® Connectors	185-192
Quick Reference Guide (Blindmate® Connectors,	186
dc-40 GHz)	
Applications	187
Pressurized SMA Planar Blind-Mate® Connectors	188
(Model 7008)	188
Rear Locking Planar Blindmate® Connectors (Model 7034)	189
Front Locking Planar Blindmate® Connectors (Model 7035	190
& 7035R)	
Rear Locking Planar Blindmate® Connectors (Model 7041)	191
Custom Blind-mate Connector Examples	190-192
Planar Crown® Universal Connector System	193-198
DIGITAL & PROGRAMMABLE ATTENUATORS &	199-242
ATTENUATOR/SWITCH CONTROLLERS	
General Information	199
Quick Reference Guide (Relay Switched, dc-3 GHz)	200
Quick Reference Guide (Edge-Line Switched,	201
dc-4/18/25 GHz)	
Quick Reference Guide (Solid-State)	202
Attenuator Units & Controllers (dc-26.5 GHz, 100 W)	203
Frequently Asked Questions	204-205
Article: Intermodulation Distortion in Programmable	206-208
Attenuators	206-208
Relay Switched	209-223
Programmable Attenuators with optional TTL Interface	209-214
(Models 3200-XE, 3201-XE, 3205-XE, 3206-XE,	
& 3209-XE)	
SmartStep Programmable Attenuators with built-in	215-217
Microprocessor-Based Driver (Models 3200T-XE,	
3201T-XE, 3205T-XE, 3206-XE, & 3209T-XE)	
Programmable Attenuators with optional TTL Interface	218-221
(3404..New, 3406 & 3408)	
SmartStep® Programmable Attenuators with built-in	222-223
Microprocessor-Based Driver (Models 3404T..New),	
3406T & 3408T)	
Edge line Switched	224-234
SmartStep® Relay Switched Programmable Attenuators	224-227
with Built-in Microprocessor-Based Driver (Models 150T,	
151T & 152T)	

<u>DESCRIPTION</u>	<u>PAGE</u>
Relay Switched Programmable Attenuator (Models 150,	228-232
151, & 152)	
Relay Switched Programmable Attenuator	233-234
(Models 153)...New	
Digital & MMIC	235-247
Digital Attenuator with built-in TTL Driver	235-236
(Model 4202-63)...New	
Digital Attenuator with built-in TTL Driver	237-238
(Model 4203-31.75 & 4203-63)...New	
Digital Attenuator with built-in TTL or USB Drivers	239-240
(Model 4205-31.75, 4205-63 & 4203-95)...New	
Pin Switched Programmable Attenuators (Models 4226	241-242
& 4228)	
GaAs Switched Programmable Attenuator (Model 4238)	243-244
Phase Compensated GaAs Switched Programmable	245-246
Attenuators (Models 4246 & 4248)	
Variable Attenuator (4258-63.75)	247
Programmable Attenuator Units & Attenuator Switch	248-260
Controllers	
SmartStep® Programmable Attenuator Units	248-251
(Models 8310/8311)	
SmartStep® Programmable Attenuator Units	252-254
(Models 8331) ...New	
SmartStep® High Power Programmable Attenuator Unit	255-257
(Model 8312)	
Attenuator / Switch Controllers	258-260
SmartStep® Programmable Attenuator/Switch	258-260
Controller (8210A)	258-260
Subsystems	261-281
Subsystems & Accessories (rewrite)	261
Subsystem Product Overview	262
Attenuator Matrices (Model 8340 concept)	263
Switch Matrices & RF Distribution Subsystems	264
WLAN System Simulator (Model 8314)	265-266
Programmable Attenuator/Switch Unit	267-268
(Model 10044)...New	
Programmable Attenuator/Switch Unit (Model 8390, -1)	269-270
SmartStep® High Power Programmable Switch (8501)	271-272
RF Switching Subsystem (8304-5)...New	273-275
L-Band 8X8 Switch Matrix (Model 10077)...New	276-277
Mobile Unit Fading Simulators	278
Complex Multi-Channel Attenuator	279
Application Specific Subsystems	280-281
Low IM Subsystems & signal Conditioning Networks	282

SPECIFICATION CHANGES: Aeroflex / Weinschel reserves the right to discontinue any item without notice and to change specifications (without notice) at any time without incurring any obligation to incorporate new features into instruments or parts previously sold.



BERYLLIUM OXIDE WARNING

Most Aeroflex / Weinschel products contain beryllium oxide substrate. DO NOT sand, scrap or tamper with this substrate in any way. For more information about beryllium oxide or disposal, refer to the Material Safety Data Sheet or contact Aeroflex / Weinschel.

 **RoHS**

Through out this catalog products that can be manufactured as RoHs compliant products will contain the  RoHS symbol located at the upper right corner of the individual data sheet.

Available Express Products



Available in US &
Canada Only....

RF & MICROWAVE COMPONENTS HIGH AVAILABILITY FOR TODAY'S APPLICATIONS

Aeroflex / Weinschel has partnered with Argosy Component Sales to provide unmatched availability of high quality RF and microwave components. As Aeroflex / Weinschel's sole product distributor in North America, Argosy carries a robust inventory of attenuators, terminations, adapters and planar blind mate connectors. Argosy ensures responsive customer service and rapid shipment anywhere in North America.

Stocked items include...

- Fixed Coaxial Attenuators
- Terminations & Loads
- Manual Step, Variable & Programmable Attenuators
- Connectors & Adapters
- Power Splitters & Dividers
- DC Blocks
- Mechanical Phase Shifters



Argosy Component Sales is increasing the efficiency and speed with which we respond to your component needs. Your application and engineering questions should still be directed to our headquarters in Maryland.

ORDERING: Just dial our existing EXPRESS distribution number (1-800-542-4457) OR visit our website www.argosysales.com, and your order will automatically be processed by Argosy's state-of-the-art distribution facility. An Argosy sales representative will take orders between the hours of 7 am to 4:30 pm Pacific Standard Time, or you can visit our website 24 hours a day, seven days a week. You will receive immediate confirmation of the product availability, pricing and delivery information.

PRODUCT AVAILABILITY: Quantities are generally limited to 20 per dB value for any given model number series. If a larger quantity of a product is desired, consult one of our sales representatives for delivery and quantity price discounts. Should you require special delivery of any product not included in the distribution service, please ask our sales representatives for availability and price.

DELIVERY SERVICES: Aeroflex / Weinschel and Argosy offers you the choice of any current delivery service offered by UPS or Federal Express. Delivery services and rates are subject to change without notice. Carrier depends upon availability of services offered.

CREDIT TERMS: Prices will be confirmed over the phone at the time of your order, or can be confirmed on our website, assuming you have pre-approved credit (with P.O. number). You can pay for your Express order in one of three ways.

1. Your...   
2. COD when supported by a purchase order number or authorization number.
3. Aeroflex / Weinschel - Argosy approved credit (with P.O number). Most accounts can be approved instantly for amounts up to \$2,000. **PAYMENT TERMS ARE NET 30 DAYS.**

For those customers not in the US or Canada who may need Express type delivery, please contact your local sales representative or Aeroflex / Weinschel for product availability and special shipping requirements.

Distribution services via Argosy Component Sales is not available to international customers or exporters.

ARGOSY COMPONENT SALES IS LOCATED AT:

13401 Bellevue-Redmond Road
Suite A-5
Bellevue, WA 98005
Telephone: (425) 562-6112
Toll-Free: (800) 542-4457
Toll-Free Fax: (866) 562-2271
Local Fax: (425) 562-2271
Email: sales@argosysales.com



Fixed Attenuators....

Model Number	Connector Type	Frequency Range (GHz)	Average Power (W)	Peak Power (kW)	Stocked Attenuation Values (dB)	SWR ¹ (maximum)	Page No.
1-XX	N (f-m)	dc-12.4	5	1	3, 5, 6, 10, 20, 30, 40, 60	1.15-1.25	36
2-XX	N (f-m)	dc-18.0	5	1	3, 4, 5, 6, 8, 10, 20, 30, 40, 50, 60	1.15-1.35	
1W-XX	N (f-m)	dc-4.0	2	0.25	3, 4, 6, 10, 20	1.25	34
3T-XX	SMA (f-m)	dc-12.4	2	0.5	1 - 10, 20, 30, 40, 50, 60	1.15-1.25	26
4T-XX	SMA (f-m)	dc-18.0	2	0.5	1 - 10, 20, 30, 40, 50, 60	1.15-1.35	
4H-XX	SMA (f-m)	dc-18.6	2	0.25	1, 2, 3, 5, 6, 7, 8, 9, 10, 20, 30	1.25-1.35	29
3M-XX	SMA (f-m)	dc-12.4	2	0.5	1 - 10, 20, 30, 40, 50, 60	1.15-1.25	27
4M-XX	SMA (f-m)	dc-18.0	2	0.5	1 - 10, 20, 30, 40, 50, 60	1.15-1.35	
23-XX-34	N (f-m)	dc-18.0	10	1	3, 6, 10, 20, 30, 40, 50, 60	1.15-1.35	47
24-XX-12	3.5mm (f-m)	dc-8.5	50	5	40	1.20-1.30	55
24-XX-33	N (f-f)	dc-8.5	50	5	6, 30	1.20-1.30	
24-XX-34	N (f-m)	dc-8.5	50	5	3, 6, 10, 20, 30, 40	1.20-1.30	
33-XX-33	N (f-f)	dc-8.5	25	5	6, 10, 20, 30	1.20-1.30	51
33-XX-34	N (f-m)	dc-8.5	25	5	3, 6, 10, 20, 30	1.20-1.30	
34-XX-33	N (f-f)	dc-4.0	25	5	10, 20, 30	1.10	49
34-XX-34	N (f-m)	dc-4.0	25	5	3, 6, 10, 20, 30	1.10	
37-XX-33	N (f-f)	dc-8.5	10	1	30	1.15-1.25	46
37-XX-34	N (f-m)	dc-8.5	10	1	3, 6, 10, 30	1.15-1.25	
40-XX-33	N (f-f)	dc-1.5	150	10	10, 20, 30, 40	1.10	62
40-XX-34	N (f-m)	dc-1.5	150	10	3, 6, 10, 20, 30	1.10	
40-XX-43	N (m-f)	dc-1.5	150	10	3, 10, 30, 40	1.10	
41-XX-11	SMA (f-f)	dc-18.0	10	1	10, 20, 30	1.20-1.35	45
41-XX-12	SMA (f-m)	dc-18.0	10	1	3, 6, 10, 20, 30	1.20-1.35	
44	N (f-m)	dc-18.0	5	1	3, 6, 10, 20, 30, 40, 50, 60	1.15-1.25	37
45-XX-33	N (f-f)	dc-1.5	250	10	30, 40	1.10	68
46-XX-34	N (f-m)	dc-18.0	25	1	3, 10, 20, 30, 40	1.20-1.35	52
47-XX-34	N (f-m)	dc-18.0	50	1	3, 6, 10, 20, 30, 40	1.20-1.45	57
48-XX-21	N (m-f)	dc-18.0	100	1	40	1.25-1.55	61
48-XX-33	N (f-f)	dc-18.0	100	1	20	1.25-1.55	
48-XX-34	N (f-m)	dc-18.0	100	1	30	1.25-1.55	
48-XX-43	N (m-f)	dc-18.0	100	1	20, 30, 40	1.25-1.55	
49-XX-33	N (f-f)	dc-8.5	150	5	3, 10, 20, 40	1.25-1.35	65
49-XX-34	N (f-m)	dc-8.5	150	5	10, 20, 30, 40	1.25-1.35	
49-XX-43	N (m-f)	dc-8.5	150	5	3, 10, 30, 40	1.25-1.35	
53-XX-33	N (f-f)	dc-2.5	500	10	20, 30	1.15	70
53-XX-34	N (f-m)	dc-2.5	500	10	30, 40	1.15	
54A-XX	SMK (f-m)	dc-40.0	2	0.2	3, 6, 10, 20, 30	1.25-1.45	33
55-XX	TNC (f-m)	dc-18.0	5	1	3, 6, 10, 20, 30	1.15-1.35	35
56-XX	3.5mm (f-m)	dc-26.5	2	0.5	3, 6, 10, 20, 30	1.10-1.25	30
57-XX-33	N (f-f)	dc-5.0	150	10	30, 40	1.20	62
57-XX-43	N (m-f)	dc-5.0	150	10	30	1.20	
58-XX-33	N (f-f)	dc-5.0	250	10	30, 40	1.20-1.25	68
58-XX-34	N (f-m)	dc-5.0	250	10	30	1.20-1.25	
58-XX-43	N (m-f)	dc-5.0	250	10	30	1.20-1.25	
59-XX-33	N (f-f)	dc-2.5	100	10	3, 10	1.15	76
59-XX-34	N (f-m)	dc-2.5	100	10	30	1.15	
59-XX-43	N (m-f)	dc-2.5	100	10	10, 20	1.15	
68-XX-33	N (f-f)	dc-4.0	100	10	30	1.20	58
68-XX-34	N (f-m)	dc-4.0	100	10	3, 20, 30	1.20	
68-XX-43	N (m-f)	dc-4.0	100	10	30	1.20	
69A-XX-12	SMA (f-m)	dc-18.0	5	0.5	3, 6, 10, 20, 30	1.15-1.35	38
72-XX-33	N (f-f)	dc-4.0	50	5	10, 20, 30	1.20	74
72-XX-43	N (f-f)	dc-4.0	50	5	20	1.20	
73-XX-43	N (m-f)	dc-8.5	100	5	3	1.25-1.35	59
74-XX-12	3.5mm (f-m)	dc-26.5	25	0.5	20	1.30-1.35	53
82-XX-34	N (f-m)	dc-3.0	1,000	10	20	1.15-1.25	72
84A-XX	2.4mm (f-m)	dc-40.0	2	0.2	3, 6, 10	1.35-1.50	32
3330A-XX	SMA (f-m)	dc-18.0	2	0.25	2 - 10, 15, 20, 30	1.25-1.40	28
3331A-XX	SMA (f-m)	dc-18.0	2	0.25	0, 1, 3 - 10, 20, 30		

Variable Attenuators....

Model No.	Frequency Range (GHz)	Atten Range (dB)	Insertion Loss (MAX dB)	SWR ¹	Connector TYPE	Page No.
940-60-11	dc-4.0	0-60	6 dB	1.50-1.60	SMA (f-f)	136
940-60-33	dc-4.0	0-60	6 dB	1.50-1.60	N (f-f)	
940-60-33-1	dc-4.0	0-60	6 dB	1.50-1.60	N (f-f)	

* VARIES WITH FREQUENCY. f = female, m = Male

Programmable Attenuators....

Model No.	Frequency Range (GHz)	Atten Range (dB)	Insertion Loss (MAX dB)	SWR ¹	Connector TYPE	Page
3200-1E	dc-2.0	0-127/1	2.80-4.75	1.25-1.35	SMA (f)	209
3200-2E	dc-2.0	0-63.75/25	2.80-4.75	1.25-1.35	SMA (f)	
3200-1E-2	dc-3.0	0-127	4.90	1.25-1.40	SMA (f)	
3201-1E	dc-2.0	0-31/1	1.80-3.75	1.30-1.35	SMA (f)	
3206-1E	dc-2.0	0-63/1	2.00-4.00	1.30-1.35	SMA (f)	

Available Express Products



Terminations....

Model No.	Frequency Range (GHz)	Average Power (Watts)	Peak Power (kW)	SWR1	Connector Type	Page No.
F1404N M1404N	dc-18.0	1	1	1.02-1.08*	N Female N Male	91
F1406A F1408	dc-18.0	2	0.5	1.05-1.21* 1.04-1.15*	SMA Female	93
M1406A M1408	dc-18.0	2	0.5	1.05-1.21* 1.04-1.15*	SMA Male	93
F1437RA M1437RA	dc-6.0 dc-6.0	2 2	0.25 0.25	1.05-1.10* 1.05-1.10*	SMA Female SMA Male	92
RS3016	dc-18.0	1	0.25	105-1.20*	SMA Male	92
1443A-1 1443A-2	dc-18.0 dc-18.0	5 5	0.5 0.5	1.20 1.20	SMA Female SMA Male	98
1455-3 1455-4 1455-4C	dc-18.0 dc-18.0 dc-18.0	2 2 2	1 1 1	1.20-1.30* 1.20-1.30* 1.20-1.30*	N Female N Male N Male w/chain	93
M1459 M1459A	dc-40.0 dc-40.0	2 2	0.5 0.5	1.15-1.25 1.10-1.15*	SMK (m) SMK (m)	95
F1418 M1418	dc-18.0 dc-18.0	10 10	1 1	1.15-1.40* 1.15-1.40*	N Female N Male	103
F1419 M1419	dc-18.0 dc-18.0	10 10	1 1	1.20-1.35* 1.20-1.35*	SMA Male SMA Male	100
1424-3 1424-4	dc-12.4 dc-12.4	5 5	5 5	1.03-1.30* 1.03-1.30*	N Female N Male	97
1425-3 1425-4	dc-12.4 dc-12.4	10 10	1 1	1.03-1.40* 1.03-1.40*	N Female N Male	102
1426-3 1426-4	dc-8.5 dc-8.5	50 50	5 5	1.20-1.30* 1.20-1.30*	N Female N Male	111
F1428 M1428	dc-1.5 dc-1.5	150 150	10 10	1.10-1.15* 1.10-1.15*	N Female N Male	119
1429-3 1429-4	dc-18.0 dc-18.0	25 25	1 1	1.20 1.20	N Female N Male	107
1430-3 1430-4	dc-18.0 dc-18.0	50 50	1 1	1.15-1.30* 1.15-1.30*	N Female N Male	112
1431-3 1431-4	dc-18.0 dc-18.0	100 100	1 1	1.20-1.30* 1.20-1.30*	N Female N Male	116
1434-3 1434-4	dc-2.5 dc-2.5	500 500	10 10	1.10 1.10	N Female N Male	123
1433-3 1433-4	dc-5.0 dc-5.0	250 250	10 10	1.10-1.15* 1.10-1.15*	N Female N Male	122
1439-3	dc-2.5	150	10	1.20	N Female	118
1440-3	dc-4.0	100	10	1.15	N Female	114
1441-3	dc-4.0	50	5	1.15	N Female	126
1452-3	dc-4.0	25	5	1.10-1.20*	N Female	104
1453-3 1453-4	dc-8.5 dc-8.5	10 10	1 1	1.15-1.25* 1.15-1.25*	N Female N Male	101

Power Splitters & Dividers....

Model No.	Type	Frequency Range (GHz)	Input Power CW (W)	Insertion Loss (MAX dB)	SWR1	Connector TYPE	Page
1506A	Divider	dc-18.0	1	7.5	1.25-1.35	N	161
1507R	Splitter	dc-4.0	1	6.5	1.15-1.25	SMA	154
1515 1515-1	Divider	dc-18.0	1	7.5	1.25-1.35	SMA	160
1534	Divider	dc-4.0	1	10.5	1.25-1.60	SMK	158
1549R	Divider	dc-4.0	1	6.5	1.25	SMA	159
1550A	Divider	dc-3.0	1	13.5	1.25	SMA	164
1575	Divider	dc-40.0	1	8.5	1.40-1.70	SMK	163
1579	Splitter	dc-26.5	0.5	8.5	1.50	3.5 mm	155
1580	Divider	dc-26.5	1	8.5	1.25-1.7	3.5 mm	162
1593	Splitter	dc-26.5	1	6.0	1.25-1.35	3.5mm	157
1594	Divider	dc-18.0	2	14.5	1.30	3.5mm	164
1870A	Splitter	dc-18.0	1	7.5	1.30	N	156

Manual Step Attenuators....

Model No.	Frequency Range (GHz)	Atten Range/ Step (dB)	Insertion Loss (MAX dB)	Maximum SWR	Connector TYPE	Page
3003-100 3010-100	dc-2.50 dc-2.5	0-70/10 0-70/1	0.3 0.7	1.20 1.35	SMA (f) SMA (f)	139
3053-100 3054-100	dc-6.0 dc-6.0	0-10/1 0-70/1	0.3-0.7* 0.8-1.3*	1.40 1.55	SMA (f) SMA	141

Planar Crown Connectors....

Model No.	Connector Type	Frequency Range (GHz)	SWR1' (max.)	Insertion Loss (dB)	Page
7004A-1 7004A-2	SMK (f) Bulkhead SMK (m) Bulkhead	dc-40.0 dc-40.0	- - - - - -	- - - - - -	195
7005A-3 7005A-4 7005A-6 7005A-7 7005A-8 7005A-10	N (f) Crown N (m) Crown 3.5mm (f) Crown 3.5mm (M) Crown TNC (F) Crown SMK (f) Crown	dc-18.0 dc-18.0 dc-34.0 dc-34.0 dc - 18 dc-40.0	1.20 1.20 1.20-1.30 1.20-1.30 1.20 1.20-1.35	0.25 0.25 0.25-0.35 0.25-0.35 0.25 0.25-0.45	195

Blindmate-Connectors, Planar....

Model No.	Connector Type	Frequency Range (GHz)	SWR1' (max.)	Insertion Loss (dB)	Page
7008	Pressurized - SMA (F)	dc-40.0	1.30-1.65	0.3-1.5	188
7034	Floating, Rear Locking - SMA (F)	dc-40.0	1.35-1.55	0.85	189
7034-1	Fixed, Rear Locking - SMA (F)	dc-40.0	1.35-1.55	0.85	189
7035	Floating, Front Locking -SMA (F)	dc-40.0	1.35-1.55	0.85	190
7035-1	Fixed, Front Locking -SMA (F)	dc-40.0	1.35-1.55	0.85	190

Adapters....

Model No.	Connector Type	Frequency Range (GHz)	SWR1' (max.)	Insertion Loss (dB)	Repeatability1'	Page
F1513 M1513	N (f) - N (f) N (m) - N (m)	dc - 18	1.10-1.15*	<0.25	0.020 dB	182
1548-13 1548-24	SMA (f) - N (f) SMA (m) - N (m)	dc-18	1.10	0.43 (max)	N: 0.006-0.010 SMA: 0.01-0.02	184
1568 1568-1	SMA (f-f) Bulkhead	dc-26.5	1.15-1.25	<0.20-<0.35	0.010-0.020	180
1587 1588 1589	SMA (f-f) SMA (m-f) SMA (m-m)	dc-26.5 dc-26.5 dc-26.5	1.15-1.20 1.15-1.20 1.15-1.20	<0.20-<0.35 <0.20-<0.35 <0.20-<0.35	0.010-0.020 0.010-0.020 0.010-0.020	181
7002-13 7002-14 7002-23 7002-24	SMA (f)-N (f) SMA (f)-N (m) SMA (m)-N(f) SMA (m)-N(m)	dc-18 dc-18 dc-18 dc-18	1.12 1.12 1.12 1.12	<0.40-<0.50 <0.40-<0.50 <0.40-<0.50 <0.40-<0.50	0.010-0.020 0.010-0.020 0.010-0.020 0.010-0.020	183

Mechanical Phase Shifters....

Model No.	Frequency Range (GHz)	Incremental Phase Shift (minimum)	Insertion Phase (Typical)	SWR (Max)	Connector TYPE	Page
917-11	dc-20.0	225° @ 20 100° @ 9	890° @ 10	1.50	SMA (F)	169
980-2 980-2K 980-3	dc-3.0 dc-3.0 dc-7.0	340° @ 3.0 340° @ 3.0 85° @ 3.0	780° @ 3.0 780° @ 3.0 700° @ 3.0	1.35 1.35 1.30	SMA (F) SMA (F) SMA (F)	167
980-4	dc-12.0	170° @ 7.0 290° @ 12.0	1200° @ 12.0	1.45	SMA (F)	170
981	dc-26.5	60° /GHz	- - -	1.80	SMA (F)	170

dc Blocks....

Model No.	Type	Connector Type	Frequency Range (GHz)	SWR1	Insertion Loss (dB)	Page No.
7003	Inside	N (f-m)	0.01-18.0	1.35-1.50	0.8	172
7006-1	Inside	SMA(f-m)	9 kHz - 20	1.30-1.50*	0.8	174
7012	Inside /Outside	SMA (f-m)	0.5 to 8.6	1.25	0.4	176

High Reliability Attenuators (dc to 28 / 40 GHz)

Since 1952, Weinschel has supplied high quality precision coaxial attenuators and terminations to Test and calibration labs throughout the world. These products offer rugged construction, frequency ranges now up to 52 GHz, many standard dB values and power handling to 1,500 Watts.

Aeroflex / Weinschel would like to announce the release of Model 32K, dc to 40 GHz, 2 Watt High Reliability Fixed Coaxial Attenuator designs. Model 32K available with SMK (SMK) (Model 32K) in dB values of 3, 6, 10, 20, and 30. Other features include 1.25-1.45 maximum SWR, ± 1.00 -1.50 dB deviation, quality connectors, and a operating temperature range of -55 °C to +100 °C.

As well as the new design Aeroflex / Weinschel is extending the upper frequency limits and the performance of a few of its standard products, i.e., Models 56 and 74 from 26.5 to 28 GHz.



Model Number	Connector Type	Frequency Range (GHz)	Average Power (W)	Peak Power (kW)	Stocked Attenuation Values (dB) ²	SWR ¹ (maximum)	Page No.
32K	SMK (f-m)	dc-40.0	2	0.50	3, 6, 10, 20, 30	1.25-1.45	44
54A-XX	SMK (f-m)	dc-40.0	2	0.2	3, 6, 10, 20, 30	1.25-1.45	33
84A-XX	2.4mm (f-m)	dc-40.0	2	0.2	3, 6, 10, 20, 30	1.35-1.50	32
56-XX	3.5mm (f-m)	dc-28.0	2	0.5	0, 3, 6, 10, 20, 30	1.10-1.25	30
74-XX-12	3.5mm (f-m)	dc-28.0	25	0.5	3, 6, 10, 20, 30	1.30-1.35	53

40 GHz Programmable Attenuators



Aeroflex / Weinschel's new 153 Series of programmable operate in the dc to 40 GHz frequency range and are available in 0 to 70 dB in 10 dB steps and 0 to 110 dB in 10 dB steps. Other features include low insertion loss & excellent repeatability; Life of 5 million operations and compact rugged construction and light weight. The table below provides a brief specification overview for these new models. (pages 233-234)

Model Number	Frequency Range (GHz)	Attenuation Range (dB)	Step Size (dB)	Insertion Loss, Max. (dB)	Maximum SWR ¹	Connector Type	Average Power (Watts)	Peak Power (Watts)
153-70 153-110	dc-40.0	0-70 0-110	10 10	3.00 4.00	1.30-2.10	SMK (2.2mm)	1	100

- Notes: 1. VARIES WITH FREQUENCY.
 2. Custom dB values available.
 XX = Standard dB Value, f = female, m = Male
 Complete Data Sheets available at www.aeroflex.com/weinschel-newproducts

Model 4205 Series Digital Attenuators

Aeroflex / Weinschel's new line of MMIC Digital Attenuator operates over the 0.2 to 6 GHz frequency range and is in a variety of attenuation ranges. These unit can be controlled using either standard TTL or USB interfaces. (pages 239-240)



- /// Ideal for Automated Test Equipment (ATE), WiMAX, 3G/4G Fading Simulators, Engineering/Production Test Lab environments
- /// Excellent Repeatability & Performance
- /// Custom Configurations Available Upon Request
- /// Ruggedized Construction

Digitally Controlled Variable PIN Attenuator, Model 4258-63.75

This new digitally controlled PIN diode attenuator provides excellent performance in the frequency range of 2-6 GHz. Attenuation levels up to 63.75 dB are programmable in increments of 0.25 dB while maintain continues signal. Each unit has an integrated driver consists of EEPROM, D/A, and V/I converter with stable attenuation from -20 to +75 °C. (page 247)



- /// Low Cost Design Solution
- /// Excellent Repeatability & Performance
- /// Custom Configurations Available Upon Request
- /// Highly Accurate Stepping
- /// Ruggedized Construction

Model 251 Bi-directional High Power Coaxial Attenuator



The Model 251 is a convection cooled, 200 W Bi-directional design that operates over the dc to 6 GHz frequency range. Available in standard dB values of 10, 20, 30, 40. Standard Type N Connectors. (page 67)

50 & 100 Attenuators & Terminations

Available as Models 90 (50 W) and 260 (100 W) Fixed Attenuators and Models 1467 (50 W) & 1468 (100 W) Terminations. (pages 58, 60, 113 & 117)



- /// Standard dB values: 3, 6, 10, 20, 30
- /// dc-18 GHz frequency operation
- /// Choice of N or SMK connectors

3-Port Short /Open / Load for Test Applications

This all in one Short/Open/Load is specifically designed for use in the wireless communications bands the Model 1591 operates over the dc to 2 GHz. (page 132)



Other Model 1591 electrical specifications:

SWR: 1.05 maximum	DC-1 GHz
1.25 maximum	1-2 GHz

Short/Open Phase Tracking:	
3° maximum	DC-1 GHz
7° maximum	1-2 GHz

Model 3204 Programmable Attenuators

Ideal for Wireless/Test Applications (page 218-221)



- /// Higher Frequency range to 6 GHz.
- /// Selection of Attenuation Ranges & Step Sizes
 - 0 to 15 dB in 1 dB steps
 - 0 to 55 dB in 1 dB steps
 - 0 to 70 dB in 10 dB steps
- /// High Quality Construction & Connectors
- /// Special Configurations Available Upon Request

Model 8331 Series Programmable Attenuator Units

Ethernet, USB & RS-232 Control (page 252-254)







- /// Provides a flexible, easy to program, low cost solution for your bench test/calibration setups and subsystem applications.
- /// Multi-Channel attenuation paths (up to 12 channels)
- /// Electromechanical & Solid-State designs with choice of frequency ranges & attenuation ranges:
 - dc to 3, 6, 18 & 26.5 GHz
 - Attenuation ranges up to 127 dB
 - Solid-State (GaAs FET & PIN)
 - New MMIC switched digital attenuators
 - Relay Switched
- /// Ideal for Automated Test Equipment (ATE), WiMAX, 3G/4G Fading Simulators, LTE, Engineering/Production Test Lab environments.

Conduction Cooled (Flat-Pack) Fixed Attenuators & Terminations





Aeroflex / Weinschel announces a New line of conduction Cooled flat-pack coaxial fixed attenuators and terminations. These product operate over the dc to 40 GHz frequency range and offer several models with power handling up to 550 watts.



Fixed Attenuators...dc-40 GHz, 5-550 Watts

Model Number	Frequency Range (GHz)	Average Power (Watts)	Peak Power (kW)	Nominal Attenuation Value (dB)	SWR	Connector Type	Page No	
253 <i>NEW</i>	dc-6.0	550	10	10, 20, 30, 40	1.10-1.20*	SMK (2.92mm) / N	80	
257 <i>NEW</i>	dc-6.0	250	10	10, 20, 30, 40	1.10	SMK (2.92mm) / N	78	
258 <i>NEW</i>	dc-6.0	250	10	10, 20, 30, 40	1.10-1.25*	SMK (2.92mm) / N	79	
268 <i>NEW</i>	dc-6.0	100	10	6, 10, 20, 30, 40	1.10-1.15*	SMK (2.92mm) / N	77	
275 <i>NEW</i>	dc-40.0	5	1	3, 6, 10, 20, 30	1.25-1.45*	SMK (2.92mm)	73	

Terminations . . . dc-22 GHz, 50-550 Watts

Model Number	Frequency Range (GHz)	Average Power (Watts)	Peak Power (kW)	SWR	Connector Type	Page No.	
1470 <i>New</i>	dc-6.0	100	1	1.20	SMK (2.92mm) / N	128	
1471 <i>New</i>	dc-6.0	250	1	1.20	SMK (2.92mm) / N	129	
1472 <i>New</i>	dc-6.0	400	1	1.20	SMK (2.92mm) / N	130	
1473 <i>New</i>	dc-6.0	550	1	1.20	SMK (2.92mm) / N	131	
1474 <i>New</i>	dc-40.0	5	1	1.25-1.45	SMK (2.92mm)	125	



Visit our website @
www.aeroflex.com/weinschel

Aeroflex / Weinschel's website is updated daily and outlines their wide variety of Standard RF & Microwave Components & Subsystems that operate over the dc to 50 GHz frequency range. Aeroflex / Weinschel also designs and manufactures Custom RF and Microwave Components and subsystems for application specific customer requirements.



Fixed Coaxial Attenuators



- /// dc to 40 GHz, up to 1,000 Watts
- /// New Conduction Cooled Designs
- /// High reliability
- /// Rugged injection molded connectors
- /// Low Intermodulation (LIM) versions available
- /// Custom connector options

General Information

In this section of the catalog, each Fixed Coaxial Attenuator is outlined utilizing individual data sheets containing product features, specifications, and outline drawings. These data sheets are preceded by a quick reference guide to help you select the Fixed Coaxial Attenuator(s) that fits your needs. The page number for each Fixed Coaxial Attenuator data sheet is given in the quick reference guide.

From the company's very first DC - 1 GHz tee attenuator, came the technology that enabled the design of the first DC - 5 GHz, the first DC - 10 GHz, and the first DC - 18 GHz coaxial attenuators. These designs led to the development of the distributed resistor card attenuator element, which is the basis for most all attenuators manufactured today from DC - 60 GHz. Until the original patents expired a few years ago, most major attenuator manufacturers in the U.S. were licensed under one or more Weinschel Engineering, Co., patents.

Also MIL-DTL-3933 Qualified - Aeroflex / Weinschel is a QPL supplier of Fixed Attenuators. Most Aeroflex / Weinschel Fixed Coaxial Attenuators can be supplied according to customer specified testing, environmental or military or government specification requirements (page 41).















Attenuator Sets of Aeroflex / Weinschel Fixed Attenuators are also available...see page 40.

NOTE: *EXPRESS* Shipment available via www.argosysales.com or 800-542-4457. Check with our distributor for current products and stocking quantities.



Low Power Fixed Attenuators...dc-40 GHz, 1-5 Watts





Model Number	Frequency Range (GHz)	Average Power (Watts)	Peak Power (kW)	Nominal Attenuation Value (dB)	SWR	Connector Type	Page No	
♦ 1 ♦ 2	dc-12.4 dc-18.0	5	1	1-6, 10, 20, 30, 40, 50, 60	1.15-1.25* 1.15-1.35*	N	36	
♦ 1W	dc-4.0	2	0.25	1-6, 10, 20	1.25	N	34	
♦ 3T ♦ 4T	dc-12.4 dc-18.0	2	0.50	1-6, 10-12, 20, 30, 40, 50, 60 1-6, 10-12, 20, 30	1.15-1.25*	SMA 1.15-1.35*	26	
♦ 3M ♦ 4M	dc-12.4 dc-18.0	2	0.50	1-10, 20, 30, 40, 50, 60	1.15-1.25* 1.15-1.35*	SMA	27	
♦ 4H	dc-18.6	2	0.25	0-10, 12, 15, 20, 30	1.15-1.35*	SMA	29	
87	dc-32.0	2	0.50	0-30 in 0.5 dB Increments	1.25	SMK (2.92mm)	31	
♦ 44	dc-18.0	5	1	1-10, 20, 30, 40, 50, 60	1.15-1.25*	N	37	
♦ 54A	dc-40.0	2	0.5	3, 6, 10, 20, 30	1.25-1.40*	SMK (2.92mm)	33	
♦ 55	dc-18.0	5	1	3, 6, 10, 20, 30	1.15-1.35*	TNC	35	
♦ 56	dc-26.5	2	0.5	0-10, 20, 30	1.10-1.25*	3.5mm	30	
♦ 69A	dc-18.0	5	0.5	1-10, 20, 30	1.15-1.35*	SMA	38	
75A	dc-40.0	5	0.2	3, 6, 10, 20, 30	1.20-1.35*	SMK (2.92mm)	39	
♦ 84A	dc-40.0	2	0.5	3, 6, 10, 20, 30	1.35-150*	2.4mm	32	
♦ 3330A ♦ 3331A	dc-18.0	2	0.25	1-10, 20, 30	1.15-1.40*	SMA	28	

* VARIES WITH FREQUENCY.

- ♦ EXPRESS Shipment available via www.argosysales.com or 800-542-4457.
Note: Other models may also be available from Express delivery.

Hi-Reliability & Space Fixed Attenuators...dc-40 GHz, 2 Watts



Model Number	Frequency Range (GHz)	Average Power (Watts)	Peak Power (kW)	Nominal Attenuation Value (dB)	SWR	Connector Type	Page No	
32	dc-18.0	2	0.50	0-20 in 0.5 dB Increments	1.15-1.35*	SMA	42	
32J	dc-32.0	2	0.50	0-30 in 0.5 dB Increments	1.25	SMK (2.92mm)	43	
32K <i>(NEW)</i>	dc-40.0	2	0.50	3, 6, 10, 20, 30	1.25-1.45*	SMK (2.92mm)	44	

* VARIES WITH FREQUENCY.

Fixed Coaxial Attenuators



Medium Power Fixed Attenuators...dc-40 GHz, 10-50 Watts

















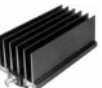

Model Number	Frequency Range (GHz)	Average Power (Watts)	Peak Power (kW)	Nominal Attenuation Value (dB)	SWR	Connector Type	Page No	
♦ 23	dc-18.0	10	1	3, 6, 10, 20, 30, 40, 50, 60	1.15-1.35*	N	47	
♦ 37	dc-8.5	10	1	3, 6, 10, 20, 30	1.15-1.25*	N	46	
♦ 24	dc-8.5	50	5	3, 6, 10, 20, 30	1.20-1.30*	SMK (2.92mm) / N	55	
♦ 33	dc-8.5	25	5	3, 6, 10, 20, 30	1.20-1.30*	SMK (2.92mm) / N	51	
♦ 34	dc-4.0	25	5	3, 6, 10, 20, 30	1.10-1.20*		49	
♦ 41	dc-18.0	10	1	1, 2, 3, 6, 10, 20, 30	1.20-1.30*	SMA	45	
♦ 46	dc-18.0	25	1	3, 6, 10, 20, 30, 40	1.15-1.35*	3.5mm / N	52	
♦ 47	dc-18.0	50	1	3, 6, 10, 20, 30, 40	1.20-1.45*	3.5mm / N	57	
♦ 74	dc-28	25	0.5	3, 6, 10, 20, 30	1.30-1.35*	3.5mm	53	
77	dc-18.0	25	1	3, 6, 10, 20, 30, 40	1.20-1.35*	7/16	50	
89	dc-40.0	20	0.2	10, 20, 30	1.25-1.40*	SMK (2.92mm)	48	
90	dc-18.0	50	1	3, 6, 10, 20, 30	1.15-1.30	3.5mm / N	56	
279	dc-40.0	10	0.2	6, 10, 20, 30	1.20-1.35*	SMK (2.92mm)	47a	

* VARIES WITH FREQUENCY.

- ♦ EXPRESS Shipment available via www.argosysales.com or 800-542-4457.
Note: Other models may also be available from Express delivery.

High Power Fixed Attenuators...dc-18.0 GHz, 100-1000 Watts



Model Number	Frequency Range (GHz)	Average Power (Watts)	Peak Power (kW)	Nominal Attenuation Value (dB)	SWR	Connector Type	Page No.	
♦ 40 ♦ 57	dc-1.5 dc-6.0	150 150	10 10	3, 6, 10, 20, 30, 40 6, 10, 20, 30, 40	1.10 1.20	N N	62	
♦ 45 ♦ 58	dc-1.5 dc-6.0	250 250	10 10	3, 6, 10, 20, 30, 40 6, 10, 20, 30, 40	1.10 1.15-1.20*	N	68	
♦ 48	dc-18.0	100	1	6, 10, 20, 30, 40	1.25-1.55*	3.5mm / N	61	
♦ 49	dc-8.5	150	5	3, 6, 10, 20, 30, 40	1.25-1.35*	SMK (2.92mm) / N	65	
♦ 53	dc-2.5	500	10	3, 6, 10, 20, 30, 40	1.10	N	70	
65	dc-2.5	150	10	3, 6, 10, 20, 30	1.20	N	63	
66	dc-18.0	150	1	10, 20, 30, 40	1.90	3.5mm / N	66	
67	dc-12.7	350	5	10, 20, 30	1.30-1.60*	N	69	
♦ 68	dc-4.0	100	10	1, 2, 3, 6, 10, 20, 30, 40	1.20	SMK (2.92mm) / N	58	
♦ 73	dc-8.5	100	5	3, 6, 10, 20, 30, 40	1.25-1.35*	SMK (2.92mm) / N	59	
78	dc-6.0	150	1	10, 20, 30, 40	1.90	7/16	54	
79	dc-6.0	150	10	6, 10, 20, 30, 40	1.20	7/16	64	
81	dc-10.0	500	5	10, 20, 30, 40	1.65-1.90*	N	71	
82	dc-3.0	1,000	10	10, 20, 30, 40	1.15-1.25*	N	72	
251 <i>NEW</i>	dc-6.0	200	10	10, 20, 30, 40	1.10-1.20	SMK (2.92mm) / N	67	
260 <i>NEW</i>	dc-18.0	100	1	3, 6, 10, 20, 30	1.15-1.30	3.5mm / N	60	

* VARIES WITH FREQUENCY.

♦ EXPRESS Shipment available via www.argosysales.com or 800-542-4457.
Note: Other models may also be available from Express delivery.

Fixed Coaxial Attenuators



Low IMD Fixed Attenuators...dc-18.0 GHz, 25-550 Watts











Model Number	Frequency Range (GHz)	Average Power (Watts)	Peak Power (kW)	Nominal Attenuation Value (dB)	SWR	Connector Type	Page No	
24-XX-XX-LIM	dc-8.5	50	5	3, 6, 10, 20, 30	1.20-1.30*	SMK (2.92mm) / N	55	
33-XX-XX-LIM	dc-8.5	25	5	10, 20, 30, 40	1.20-1.30*	SMK (2.92mm) / N	51	
46-XX-XX-LIM	dc-18.0	25	1	10, 20, 30, 40	1.15-1.30*	3.5mm / N	52	
47-XX-XX-LIM	dc-18.0	50	1	10, 20, 30, 40	1.20-1.45*	3.5mm / N	57	
48-XX-XX-LIM	dc-18.0	100	1	10, 20, 30, 40	1.25-1.55*	3.5mm / N	61	
57-XX-XX-LIM	dc-6.0	150	10	10, 20, 30, 40	1.20	N	62	
58-XX-XX-LIM	dc-6.0	250	10	10, 20, 30, 40	1.20-1.25*	N	68	
49-XX-XX-LIM	dc-8.5	150	5	10, 20, 30, 40	1.25-1.35*	N	65	
53-XX-XX-LIM	dc-2.5	500	10	10, 20, 30, 40	1.10	N	70	
77-XX-XX	dc-18.0	50	1	3, 6, 10, 20, 30, 40	1.20-1.35*	7/16	50	
78-XX-XX	dc-18.0	150	1	10, 20, 30, 40	1.90	7/16	54	
79-XX-XX	dc-6.0	150	10	10, 20, 30, 40	1.20	7/16	64	
90-XX-XX-LIM <i>NEW</i>	dc-18.0	50	1	3, 6, 10, 20, 30	1.15-1.30	3.5mm / N	56	
253-XX-XX-LIM <i>NEW</i>	dc-6.0	550	10	10, 20, 30, 40	1.10-1.20*	SMK (2.92mm) / N	80	
257-XX-XX-LIM <i>NEW</i>	dc-6.0	250	10	10, 20, 30, 40	1.10	SMK (2.92mm) / N	78	
258-XX-XX-LIM <i>NEW</i>	dc-6.0	250	10	10, 20, 30, 40	1.10-1.25	SMK (2.92mm) / N	79	
260-XX-XX-LIM <i>NEW</i>	dc-18.0	100	1	3, 6, 10, 20, 30	1.15-1.30	3.5mm / N	60	
268-XX-XX-LIM	dc-6.0	100	10	10, 20, 30, 40	1.10-1.15*	SMK (2.92mm) / N	77	

* VARIES WITH FREQUENCY.

Conduction Cooled...dc-40 GHz, 5-550 Watts



Model Number	Frequency Range (GHz)	Average Power (Watts)	Peak Power (kW)	Nominal Attenuation Value (dB)	SWR	Connector Type	Page No	
♦ 59	dc-2.5	100	10	3, 6, 10, 20, 30, 40	1.15	SMK (2.92mm) / N	76	
72	dc-4.0	50	1	3, 6, 10, 20, 30, 40	1.20	SMK (2.92mm) / N	74	
86	dc-22.0	50	1	3, 6, 10, 20, 30	1.30	3.5mm	75	
253 <i>NEW</i>	dc-6.0	550	10	10, 20, 30, 40	1.10-1.20*	SMK (2.92mm) / N	80	
257 <i>NEW</i>	dc-6.0	250	10	10, 20, 30, 40	1.10	SMK (2.92mm) / N	78	
258 <i>NEW</i>	dc-6.0	400	10	10, 20, 30, 40	1.10-1.25*	SMK (2.92mm) / N	79	
268 <i>NEW</i>	dc-6.0	100	10	6, 10, 20, 30, 40	1.10-1.15*	SMK (2.92mm) / N	77	
275 <i>NEW</i>	dc-40.0	5	1	6, 10, 20, 30	1.25-1.45*	SMK (2.92mm)	73	
284 <i>NEW</i>	dc-10.0	50	5	3, 6, 10, 20, 30, 40	1.15-1.30*	SMK (2.92mm) / N	74a	

* VARIES WITH FREQUENCY.

Fixed Coaxial Attenuators



Frequently Asked Questions about Fixed Coaxial Attenuators....

What are the advantages of Weinschel's fixed attenuators?

Aeroflex / Weinschel low power fixed attenuators feature a combination of advantages over other designs:*

1. Most Aeroflex / Weinschel attenuators feature injection molded dielectric for better center pin captivation and alignment. Injection molded dielectric also eliminates the need for the epoxy hole "stake" as seen in other designs. This epoxy hole in other designs is subject to RF leakage and movement when exposed to environmental extremes and prolonged use.
2. Aeroflex / Weinschel fixed attenuators have a proprietary resistor element, fired at 950°C for superior long term stability over temperature, power and time. The attenuator element is trimmed for precise custom attenuation values.
3. Aeroflex / Weinschel fixed attenuators have no solder contacts. They feature spring loaded plunger contacts to the resistor cards that provide expansion tolerance over wide temperature and power ranges.
4. Aeroflex / Weinschel fixed attenuators are made with high quality materials and machined to very close tolerances. The result is a design that stands up to severe environmental and multiple matings.
5. High power designs feature special high temperature dielectric support beads.

Does Aeroflex / Weinschel offer high reliability fixed attenuators?



Yes, most Most Aeroflex / Weinschel Fixed Coaxial Attenuators can be supplied according to customer specified testing, environmental or military or government specification requirements.

Hi-Rel units can be laser-marked and are manufactured from materials which have a TML of less than 1% and CVCM less than 0.1%.

What is a bidirectional and unidirectional attenuator?

All Aeroflex / Weinschel attenuators are bidirectional unless they are specified as unidirectional in the power rating specification. Bidirectional means the maximum specified power can be applied to either the input or output of the attenuator. Unidirectional means the maximum specified power can only be applied to the input port of the attenuator. Unidirectional designs allow for smaller overall package sizes and reduced costs. All our attenuators have maximum average and peak pulse input power limits. The average power limit decreases linearly as the ambient temperature increases. If these limits are exceeded, burnout of the attenuator element results or its calibration may be permanently changed. When used within its specifications, an attenuator is an indispensable component in measurement and system applications.

*Most designs, some features may not apply to certain low cost attenuator designs.

What dB values are available besides those in the catalog?

Most any dB value is available; however you should consult your local sales representative or the factory for design availability for a particular dB value for the selected model. There is generally an additional charge for non-catalog values.

Can Aeroflex / Weinschel provide attenuators for space applications?

Yes. Aeroflex / Weinschel fixed attenuators are being used on a wide variety of military and commercial communication satellites. "S" level fixed attenuators can be provided for any dB value up to 40 dB from dc to 52 GHz. Aeroflex / Weinschel has recently introduced Models 32K (page 30) and 32L (page 31) standard fixed attenuators that operates from dc to 42 or 52 GHz. These attenuators offer superior electrical and mechanical design that is ideally suited for space applications.

Aeroflex / Weinschel's use of precision connectors, injection molded captivation of connector contacts (no solder or contact fingers) and very precise and stable resistors result in a superior electrical and mechanical design that is ideally suited for space applications.

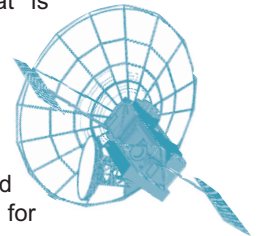

Aeroflex / Weinschel program experience includes:

Aussat (Optus)	SSTI	JCSAT
KOREASAT	GlobalStar	GEM
TDRSS	ICO	SMTS
TELSTAR	INTELSAT	AGILA
GOES	ACeS	MSAT
MILSTAR	EOS	TOMS
...and many others.		

Aeroflex / Weinschel offers extensive testing programs for space qualified attenuators and other components that can include:

Random Vibration: Random and/or Sine Vibration up to 100 g rms.

Monitored Thermal Cycle: Units monitored for open condition over -55 °C to +100 °C, 15 cycles.S.

Thermal Shock: Performed per MIL-STD-202G, Method 107.

Burn-In Testing: Performed at rated power and operating temperature from 96 to 360 hours typical.

Mechanical Shock: Performed per MIL-STD-202, Method 213 Test Condition F up to 1000 G peak.

Moisture Resistance Testing: Performed per MIL-STD-202, Method 106. (except sub-cycle 7b is not applicable) with connectors capped.

Salt Spray: Performed per MIL-STD-202, Method 101 with connectors capped.



Can Weinschel provide special fixed attenuators?

Yes. Aeroflex / Weinschel has produced over 2000 custom fixed attenuator designs. Specials continue to be a significant part of Weinschel's product offering. Special features may include:

1. Custom Connector Configurations
2. Matched Pairs or Sets
3. Lower VSWR & Higher Accuracy
4. Special Mounting & Environmental Conditions
5. Unique Test Requirements & Data

Does Weinschel offer any attenuators with IM3 specified?

Yes Aeroflex / Weinschel has recently introduced new as well as updated models specifically for applications requiring low intermodulation distortion. Models are available with the low IM options are...24, 33, 40, 45, 46, 47, 48, 48, 53, 57, & 58. Refer to the page 15 for a product line overview or the specific data sheet for IM3 details.

How is the temperature or power coefficient specification applied?

These specifications tell how much the attenuation will change when the ambient temperature or input power changes. First multiply the catalog temperature coefficient or power coefficient by the ambient temperature range or input power range to which the attenuator will be exposed. Then multiply that number by the dB value of the attenuator. The result is the maximum change in attenuation than can be expected over the ambient temperature range or power range that was specified.

How is the attenuator power rating calculated?

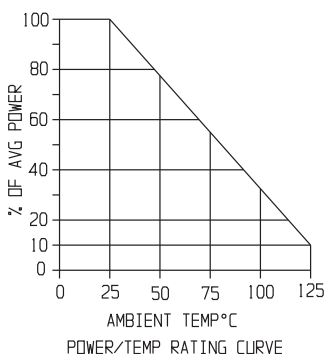

An attenuator will handle specified power at ambient temperatures as specified in the catalog. No special fan cooling is required. At higher temperatures the power rating is calculated by using catalog specifications and a straight line graph (Example shown above). For instance the power rating of the Model 48 attenuator is 100 watts to 25°C and 10 watts at

125°C. Using linear graph paper, plot a straight line between these two points. This plot shows that the power rating at 75°C is approximately 56 Watts.

Does Aeroflex / Weinschel offer attenuators sets or attenuation test kits?

Aeroflex / Weinschel offers a variety of attenuation standard sets consisting of precision designed fixed attenuators. These sets are ideally suited for standards and research laboratories as well as production, quality control, and inspection departments. Aeroflex / Weinschel attenuation sets are available in either 3, 6, 10, 20 dB or 1, 3, 6, 10, 20,

30 dB attenuation values. Each attenuator is tested in 1 GHz intervals to minimize interpolation error. The attenuator sets are available in stainless steel type N (Model 1 & 44), and 3.5mm (Model 56) connectors. Custom sets with other connector type and higher power sets are also available upon request. Refer to page 66 for more details.



What is Third-Order Intermodulation Distortion?

(IM3) Intermodulation distortion (IM) consists of the spurious signals which result from the mixing of nth order frequencies in the non-linear elements of a component. Third order intermodulation distortion is of particular interest because third order products typically represent the highest level distortion appearing close to the desired signal, and as such the highest level non-filterable distortion. Third order IM level (IM3) is tested by injecting two pure tones of equal magnitude (f1 and f2) into the component to be tested. The third order IM products will appear in the output spectrum at the frequencies 2f1-f2 and 2f2-f1. These products are characterized by defining their level (in dBc) relative to the fundamental output tones at either f1 or f2.

Applications...

Aeroflex / Weinschel Attenuators are used in a wide variety of applications in the electronic field for the control or measurement of radio frequency energy. Attenuators are used as accurate standards in the measurement of loss or gain by the RF substitution method. They are used as a means of extending the dynamic range of measuring equipment such as power meters, field intensity meters, spectrum analyzers, and amplifiers, or to prevent overloading of receivers and amplifiers. They also reduce, by masking, the effects of variable or mismatched impedances on such circuit elements as oscillator, T-junctions, mixers, etc.

Fixed Attenuators can satisfy almost any requirement involving a reduction in power. Attenuators designed and manufactured by Aeroflex / Weinschel are very stable and remain precision calibrated over wide ranges of humidity, temperature, and other ambient conditions for long periods of time.

Fixed Coaxial Attenuators

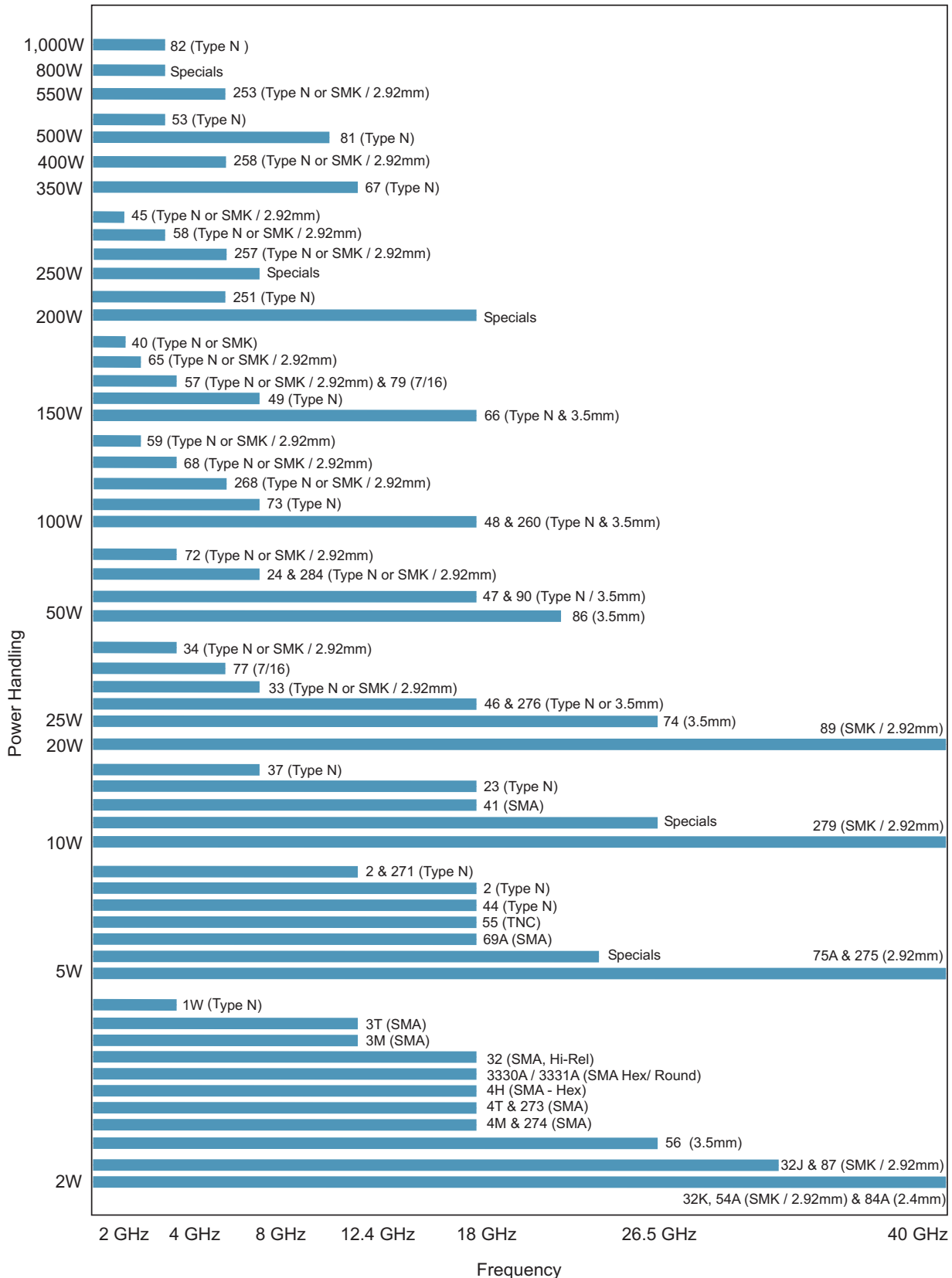

Attenuation Selection Guide: Power Handling / Frequency / Connector Type

Understanding Temperature & Power Coefficient in Attenuators

By the Components Engineering Staff @ Aeroflex / Weinschel
 Article written By Jimmy Dholoo, VP Engineering & Rob Sinno, Design Engineer

Temperature Coefficient of Resistance, TCR, is a well-known parameter in the Electronics Industry. Power Coefficient of Resistance, PCR, is not such a familiar term. Manufacturers seldom provide PCR specifications for their resistors. TCR and PCR are usually expressed in parts per million per degree (ppm / °C), or parts per million per watt (ppm / W). Applying PCR in an example, a 10-Watt, 100-ohm resistor with a PCR of +/- 200ppm/W could change by +/- 0.2 ohms when subjected to 10 Watts of average power at ambient temperature (100Ωx10Wx200x10⁻⁶ /W).

Attenuators in their discrete form are usually a combination of chip resistors in a Pi or T network, and the type of resistors selected for such networks depends on the desired frequency, temperature and power handling requirements. The individual chips in such a network might either be thin- or thick-film resistors. For higher frequency applications, attenuators usually take on a distributed form, with a resistive sheet of thick-film or thin-film terminated with suitable metalization, Figure 1. The most common material for thick-film resistors is ruthenium dioxide. Popular thin film materials are nichrome, tantalum nitride and tin oxide.

a - Pi Network:

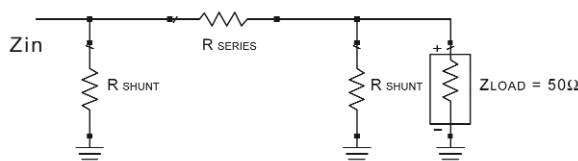

b - T Network:

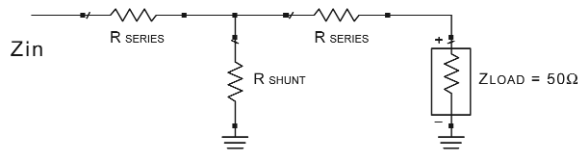

c - Distributed Attenuator

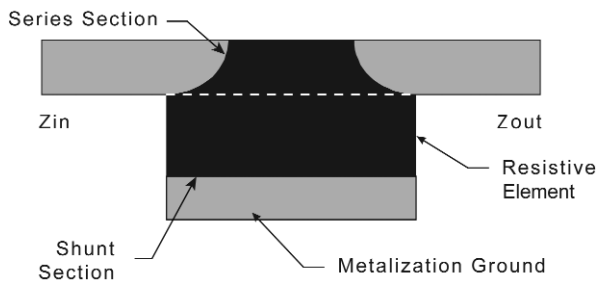

Figure 1.

Almost all the fixed and programmable attenuators offered by Weinschel specify a Temperature Coefficient of Attenuation (TCA) and a Power Coefficient of Attenuation (PCA) in the product data sheets. Based on the inquiries we receive about the interpretation of these specifications, it seems that some basic explanation is necessary so the end user can correctly forecast the worst case scenario for his system; i.e. what attenuation change might be expected at temperature and power extremes.

Case 1: TCA of Fixed Attenuators

All of Weinschel's fixed attenuators are of the distributed type and of a proprietary thin-film Tin Oxide composition. The tin oxide is deposited on a ceramic substrate at 930°C via a chemical vapor deposition process and terminated with gold metalization. Depending on the product type, the substrate could be Alumina, BeO or ALN. The vast fixed attenuator family covers a frequency range of DC to 40 GHz, and the power handling ranges from as low as 2 watts to 1000 watts. The TCA for every fixed product is specified as 0.0004dB/dB/°C because the predominant factor determining the TCA is the TCR of the tin oxide film. The substrate material, the sheet resistivity and the mechanical contacts between the connectors and the substrate and between the substrate and the grounds do contribute to the overall TCA, but to a much lesser extent. The TCA is usually measured at a power level low enough so as not to cause any significant warming of the unit. Attenuation is measured at various ambient temperatures over a specified frequency range. The worst-case coefficient arrived at is based on the maximum attenuation change over the frequency band. Military Standard, MIL-A-3993 for fixed attenuators calls for a TCA of 0.0004dB/dB/°C. Over a 100°C ambient temperature change, a 30 dB attenuator would change by a maximum of 1.2 dB at low signal levels. In reality, the TCA of Weinschel attenuators is 0.0001dB/dB/°C. The maximum change would only be 0.3 dB on a 30 dB attenuator, thus providing a significant guard band to the user.

Figure 2 is a theoretical plot showing the attenuation variation on a 10 dB distributed attenuator as a function of the TCR of the resistive thin-film at two temperature extremes, -75°C and +125°C. It is interesting to note that the change in attenuation is rather small over such a wide swing of both temperature and TCR. Figure 3 is a similar plot of the impedance variation of the same attenuator and this shows a significant change from the nominal 50-ohm impedance. Three obvious conclusions can be drawn from these plots:

- As long as the shunt and series resistive elements of an attenuator have the same TCR the attenuation will always increase at DC, independent of the temperature and the magnitude of the TCR. Distributed film attenuators will always behave in this manner because the shunt and series sections are formed from the same resistive film and therefore have the same TCR. Discrete attenuator networks may not behave in this

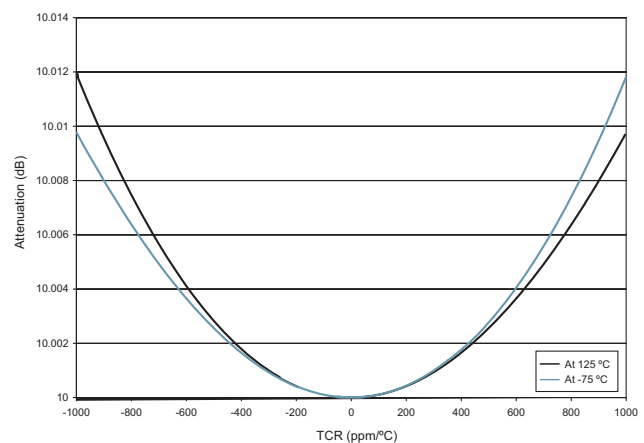

Figure 2. Attenuation as a Function of TCR for Two Temperature Extremes, 25 ± 100 °C.

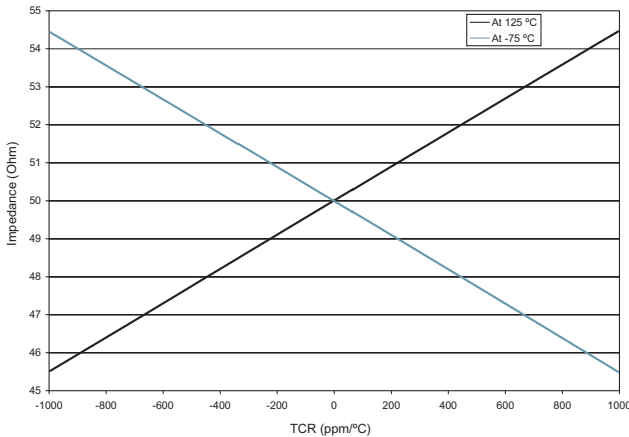

Figure 3. Impedance as a Function of TCR for Two Temperature Extremes, 25 ± 100 °C.

manner because the discrete shunt and series chip resistors may have different TCRs.

- Since an increase in the resistance of the series element increases the attenuation and an increase in the resistance of the shunt element reduces the attenuation the overall change in the attenuation is very small and far less than the change in the individual resistors.
- Materials with poor TCR figures will seriously impact the impedance of distributed attenuators and significantly degrade the SWR, with little effect on the DC attenuation.

Case 2: PCA of Fixed Attenuators

Though the specified TCA of all attenuators is the same, the PCA varies across the product line since it is no longer just a function of the tin oxide resistive film. It also depends on the substrate material, metalization, packaging, heat sinking and forced cooling, if any. The effect of high power/high voltage on this resistive film is quite different from that of a temperature increase at low voltages/low power. A detailed discussion of this is beyond the scope of this article but it is important to note that this effect is a function of the electrical stress in the film and will depend on the dimensions of the resistive film, and so is a function of the size and shape of the resistor. Also, it is worth clarifying that referring to this high voltage effect as a "Power Coefficient!" is misleading since the rate of change of resistance with applied voltage is not constant and the film exhibits some degree, albeit small, of non-linearity.

From the Weinschel fixed attenuator product line, a typical 2 W attenuator has a PCA of < 0.005 dB/dB/W, so a 30 dB unit would change by less than 0.3 dB (across the full frequency band, when the incident power increases from, say, 10mW to 2 Watts. Similarly, a 500W unit with a PCA of 0.0001dB/dB/W would change by less than 1.5dB (over its operating frequency band when the incident power increases from a low level signal to the full 500 watts.

PCA measurements are not easily made. Just as the TCA is measured at a constant low power level with varying ambient temperatures, the PCA must be measured at a constant ambient temperature of 25°C with varying power and over the entire operating frequency range. To carry out such measurements with good accuracy requires a set of high-power, broadband bias tees and good matching techniques. The test set-up is shown in the MIL- A-3933 document.

Case 3: TCA of switched Programmable Attenuators

Switched Programmable attenuators typically comprise several attenuator "cells", usually in a binary sequence: 1 dB, 2 dB, 4 dB, 8 dB, 16 dB, 32 dB etc, Fig 4. These cells are selectively switched ON from their `zero' state, using DPDT relays for electromechanical models and PIN diodes, for solid state versions. Programmable attenuators basically have two states, a zero state when the unit is sitting in its minimum insertion loss position and an attenuate state when the unit is sitting in any of the selected attenuation positions. The interpretation of TCA for these products has at times raised questions because there are two TCA figures associated with them. The first is the Absolute TCA, which is derived from the total change in any selected attenuation, between two temperatures at low signal levels. The second is the relative or Incremental TCA. Programmable attenuators are frequently installed in systems and instruments to accurately control RF signal levels. Their insertion loss in the ZERO attenuation position usually becomes part of the overall system loss and is zeroed out in the normalization process. What is important in such cases is the accuracy of the incremental attenuation with reference to the normalized state and, therefore, it is the Incremental TCA that is more relevant to the designer/user. Incremental TCA is derived from the change in the incremental attenuation state at two temperatures; i.e., the normalization of the zero is carried out at both temperatures.

The blue plot in Figure 4 shows the change in the zero state attenuation of an 8 cell electromechanical unit. It was generated by first normalizing its zero state loss at room temperature and then raising the ambient to 100°C. The major attenuation change over temperature comes from the 8 relays. Typically a 75-degree change causes a 0.5 dB change in the Zero insertion loss (0.063 dB per relay). For this unit, if normalization were carried out at 25°C, the 1 dB cell switched ON and the ambient raised to 100°C, the 1 dB cell would read 1.5 dB at around 1.5 GHz. This would yield the worst-case Absolute TCA of 0.0066 dB/dB/°C (0.5dB /1dB/75°C). As a comparison, the red plot in Figure 4 shows that the Incremental attenuation change of the 32 dB is only 0.05 dB at about 2 GHz because we measure it at 25°C with one normalization and again at 100°C with another normalization. So all changes due to the relays are masked and the worst-case Incremental TCA works out to be 0.000021 dB/dB/°C (0.05dB/32dB/75°C). This shows that the ruthenium based thick-film attenuators screened on a ceramic substrate hardly change over this temperature range. Almost all the temperature variance is therefore attributable to the relay contacts.

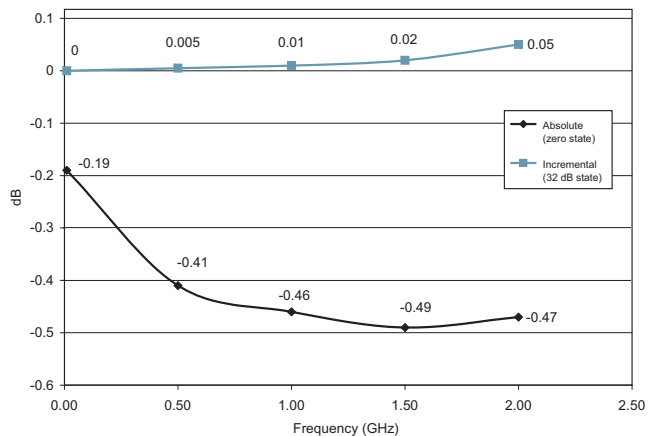

Figure 4 -- 8 Cell Relay Based Programmable Attenuator: Change in the Absolute & Incremental Attenuation from 25°C and 100°C

Model 3T Model 4T Ruggedized SMA Connectors

dc to 12.4 GHz
dc to 18.0 GHz
2 Watts



Features

- /// Rugged injection molded connectors.
- /// Designed to meet environmental requirements of MIL-DTL-3933.
- /// Small Package Size
- /// Usable to 22 GHz.

Specifications

NOMINAL IMPEDANCE: 50 Ω

FREQUENCY RANGE: Model 3T: dc to 12.4 GHz
Model 4T: dc to 18.0 GHz

MAXIMUM DEVIATION OVER FREQUENCY:

Nominal ATTN (dB)	3T	4T
1 - 6	± 0.30	± 0.30
7 - 12	± 0.30	± 0.50
20	± 0.50	± 0.70
30, 40	± 0.75	± 1.00
50, 60	± 1.00	± 1.50

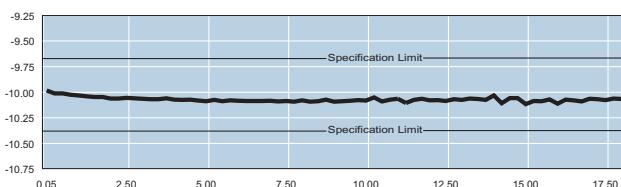

Typical Attenuation Performance of 4T-10

MAXIMUM SWR:

Frequency (GHz)	3T	4T
dc - 4	1.15	1.15
4 - 8	1.20	1.20
8 - 12.4	1.25	1.25
12.4 - 18	---	1.35

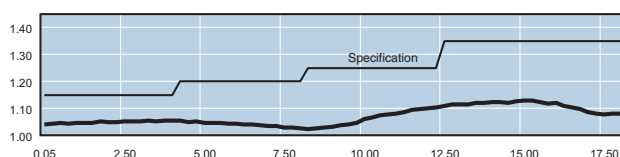

Typical SWR of a Model 4T-10

POWER RATING: 2 watts **average** to 25°C ambient temperature, derated linearly to 0.5 watts at 125°C. 500 watts **peak** (5 μsec pulse width; 0.2% duty cycle).

POWER COEFFICIENT: < 0.005 dB/dB/watts

TEMPERATURE COEFFICIENT: < 0.0004 dB/dB/°C

TEMPERATURE RANGE: -55°C to +125°C

TEST DATA: Swept data plots of attenuation and SWR from 50 MHz to 12.4 / 18 GHz is available at additional cost.

CONNECTORS: SMA connectors per MIL-STD-348 interface dimensions - mate nondestructively with SMA, 3.5mm, SMK and other 2.92mm per MIL-C-39012.

CONSTRUCTION: Passivated stainless steel body and connectors; gold plated beryllium copper contacts.

WEIGHT (Both Models):

dB VALUE	WEIGHT (Net)
1 - 12	3.9 g (0.14 oz)
20	4.3 g (0.15 oz)
30	6.5 g (0.23 oz)
40, 50, 60	12.7 g (0.45 oz)

PHYSICAL DIMENSIONS:

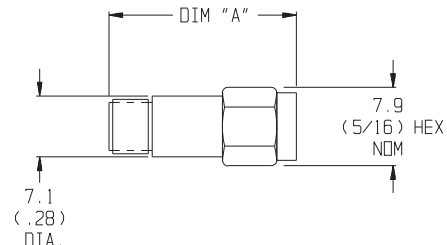

dB VALUE	DIM A ± 0.5 (0.02)
1-12	21.8 (0.86)
20	23.9 (0.94)
30	26.5 (1.04)
40, 50, 60	34.3 (1.35)

NOTE: All dimensions are given in mm (inches) and are maximum, unless otherwise specified.

MODEL NUMBER DESCRIPTION:

Example:

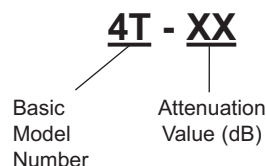

Fixed Coaxial Attenuators



Model 3M Model 4M Ruggedized SMA Connectors

dc to 12.4 GHz
dc to 18.0 GHz
2 Watts



Features

- /// Rugged injection molded connectors.
- /// Designed to meet environmental requirements of MIL-DTL-3933.
- /// Usable to 22 GHz.

Specifications

NOMINAL IMPEDANCE: 50 Ω

FREQUENCY RANGE: Model 3M: dc to 12.4 GHz
Model 4M: dc to 18.0 GHz

MAXIMUM DEVIATION OVER FREQUENCY:

Nominal ATTN (dB)	3M	4M
1 - 2	± 0.30	± 0.50
3 - 6	± 0.30	± 0.30
7 - 10	± 0.30	± 0.50
20	± 0.50	± 0.70
30, 40	± 0.75	± 1.00
50, 60	± 1.00	± 2.00

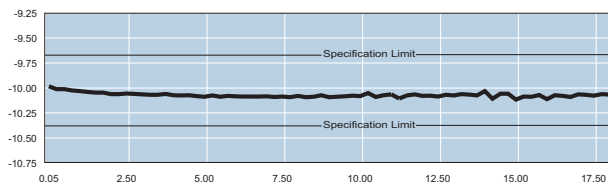

Typical Attenuation Performance of 4M-10

MAXIMUM SWR:

Frequency (GHz)	3M	4M
dc - 4	1.15	1.15
4 - 8	1.20	1.20
8 - 12.4	1.25	1.25
12.4 - 18	---	1.35

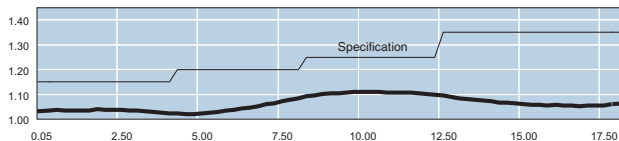

Typical SWR of a Model 4M-10

POWER RATING: 2 watts **average** to 25°C ambient temperature, derated linearly to 0.5 watts at 125°C. 500 watts **peak** (5 μsec pulse width; 0.2% duty cycle).

POWER COEFFICIENT: < 0.005 dB/dB/watts

TEMPERATURE COEFFICIENT: < 0.0004 dB/dB/°C

TEMPERATURE RANGE: -55°C to +125°C

TEST DATA: Swept data plots of attenuation and SWR from 50 MHz to 12.4 / 18 GHz is available at additional cost.

CONNECTORS: SMA connectors per MIL-STD-348 interface dimensions - mate nondestructively with MIL-C-39012 connectors.

CONSTRUCTION: Passivated stainless steel body and connectors; gold plated beryllium copper contacts.

WEIGHT (Both Models):

dB VALUE	WEIGHT (Net)
1 - 10, 20	10 g (0.35 oz)
30, 40, 50, 60	20 g (0.70 oz)

PHYSICAL DIMENSIONS:

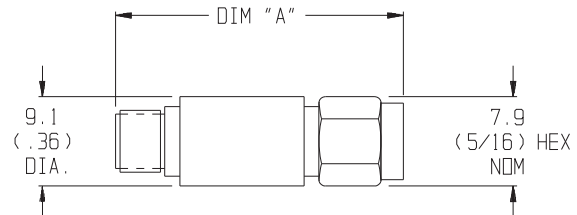

dB VALUE	DIM A ± 0.5 (0.02)		
	STD	Prefix F	Prefix M
1 - 10, 20	30.5 (1.20)	29.7 (1.17)	32.3 (1.27)
30, 40, 50, 60	47.0 (1.85)	46.2 (1.82)	47.7 (1.88)

NOTE: All dimensions are given in mm (inches) and are maximum, unless otherwise specified.

MODEL NUMBER DESCRIPTION:

Example:

***4M - XX**

Basic Model Number

Attenuation Value (dB)

*Add Prefix M for double male and F for double female connectors.

Models 3330A & 3331A General Purpose, Subminiature SMA

dc to 18.0 GHz
2 Watts

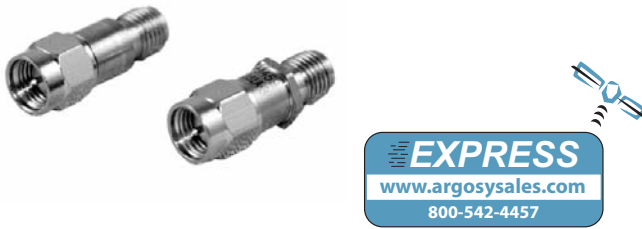

Features

- /// **Low Cost** - These general purpose attenuators offer subminiature size, broadband frequency response, and attenuation values from 1 to 30 dB at low, competitive prices.
- /// **Two Configurations** - Round body Model 3330A and a hex body Model 3331A.
- /// **Ideal for Bulk Quantity Requirements.**

Specifications

NOMINAL IMPEDANCE: 50 Ω

FREQUENCY RANGE: dc to 18.0 GHz

MAXIMUM DEVIATION OVER FREQUENCY:

Nominal ATTN (dB)	Deviation (dB)
0-6	± 0.30
7-10, 20	± 0.50
30	± 0.75

MAXIMUM SWR:

Frequency (GHz)	SWR
dc - 4	1.15
4 - 12.4	1.30
12.4 - 18.0	1.40

POWER RATING: 2 watts **average** to 25°C ambient temperature, derated linearly to 0.5 watts @ 125°C. 250 watts **peak** (5 μsec pulse width; 0.4% duty cycle).

TEMPERATURE RANGE: -55°C to +125°C.

CONNECTORS: SMA connectors per MIL-STD-348 interface dimensions mate nondestructively with MIL-C-39012 connectors.

CONSTRUCTION: Passivated stainless steel body and connectors; gold plated beryllium copper contacts.

WEIGHT: 5.6 g (0.2 oz) maximum (Both Models)

PHYSICAL DIMENSIONS:

Model 3330A (Round):

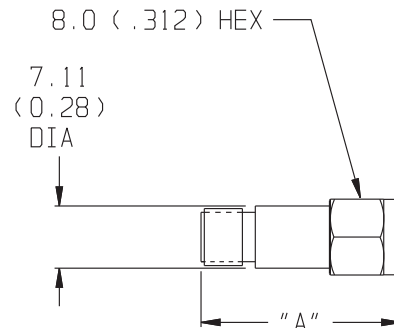

Model 3331A (Hex):

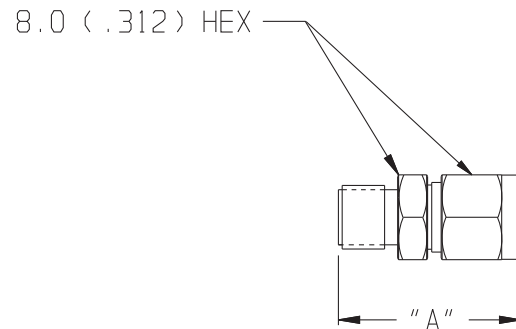

dB VALUE	DIM A
1 - 10	21.72 ± 0.51 (0.855 ± 0.020)
20, 30	25.02 ± 0.51 (0.985 ± 0.020)

NOTE: All dimensions are given in mm (inches) and are maximum, unless otherwise specified.

MODEL NUMBER DESCRIPTION:

Example:

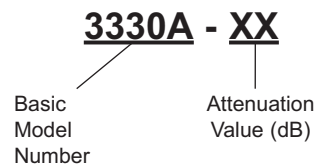

Fixed Coaxial Attenuators



Model 4H Hex Body Precision SMA Connectors

dc to 18.6 GHz
2 Watts



CONNECTORS: SMA connectors per MIL-STD-348 interface dimensions mate nondestructively with MIL-C-39012 connectors.

CONSTRUCTION: Stainless steel body and connectors; gold plated beryllium copper contacts.

WEIGHT: 5.0 g (0.18 oz) maximum

PHYSICAL DIMENSIONS:

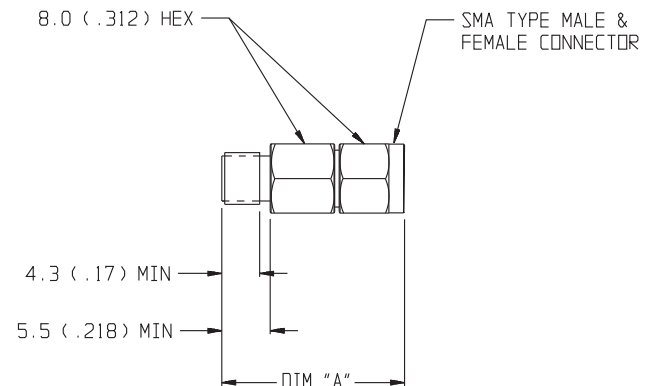

Features

- /// **Subminiature** - These attenuators offer the smallest package size with broadband frequency response, and attenuation values from 0 to 10, 12, 15, 20 & 30 dB.
- /// **Designed to meet environmental requirements of MIL-DTL-3933.**
- /// **Precision SMA Connectors.**
- /// **Usable to 23 GHz.**

Specifications

NOMINAL IMPEDANCE: 50 Ω

FREQUENCY RANGE: dc to 18.6 GHz

MAXIMUM DEVIATION OVER FREQUENCY:

Nominal ATTN (dB)	Deviation (dB)
0	± 0.40
1-10	± 0.30
12, 15, 20, 30	± 0.70

MAXIMUM SWR:

Frequency (GHz)	SWR
dc - 12.4	1.25
12.4 - 18.6	1.35

POWER RATING: 2 watts **average** to 25°C ambient temperature, derated linearly to 0.5 watts @ 125°C. 250 watts **peak** (5 μsec pulse width; 0.4% duty cycle).

POWER COEFFICIENT: < 0.005 dB/dB/watt

TEMPERATURE COEFFICIENT: < 0.0004 dB/dB/°C

TEMPERATURE RANGE: -50°C to +125°C

dB VALUE	DIM A
0-10	19.0 (0.75)
12, 15, 20	21.6 (0.85)
30	24.0 (0.95)

NOTE: All dimensions are given in mm (inches) and are maximum, unless otherwise specified.

MODEL NUMBER DESCRIPTION:

Example:

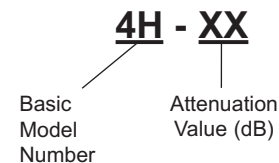

Model 56 3.5mm Connectors

dc to 26.5 GHz
2 Watts



Features

- /// Useable to 28 GHz
- /// Precision 3.5mm Connectors
- /// Low SWR & Flat Response

Specifications

NOMINAL IMPEDANCE: 50 Ω

FREQUENCY RANGE: dc to 26.5 GHz

MAXIMUM DEVIATION OVER FREQUENCY (dB):

Nominal ATTN (dB)	DEVIATION (dB)
0	+ 0.50
3, 6, 10	± 0.60
20, 30	± 0.75

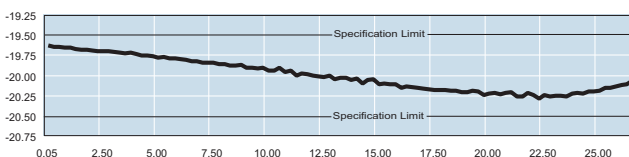

Typical Attenuation Accuracy of a 56-20

MAXIMUM SWR:

Frequency (GHz)	SWR
dc - 8	1.10
8 - 12.4	1.15
12.4 - 26.5	1.25

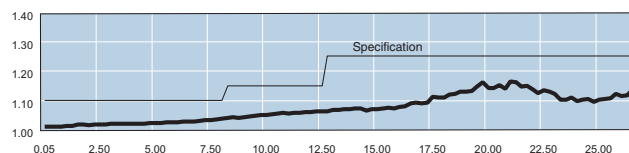

Typical SWR of a 56-20

POWER RATING: 2 watts **average** to 25°C ambient temperature, derated linearly to 0.2 watts at +100°C. 500 watts **peak** (5 μsec pulse width; 0.2% duty cycle).

POWER COEFFICIENT: < 0.005 dB/dB/watts

TEMPERATURE COEFFICIENT: < 0.0004 dB/dB/°C

TEMPERATURE RANGE: -55°C to +100°C.

TEST DATA: Swept data plots of attenuation and SWR from 50 MHz to 26.5 GHz is available at additional cost.

CONNECTORS: 3.5mm connectors - contact pin recession (0.003 maximum) - mate nondestructively with SMA, 3.5mm, SMK and other 2.92mm per MIL-C-39012.

CONSTRUCTION: Stainless steel body and connectors; gold plated beryllium copper contacts.

WEIGHT: 8 g (0.28 oz) maximum

PHYSICAL DIMENSIONS:

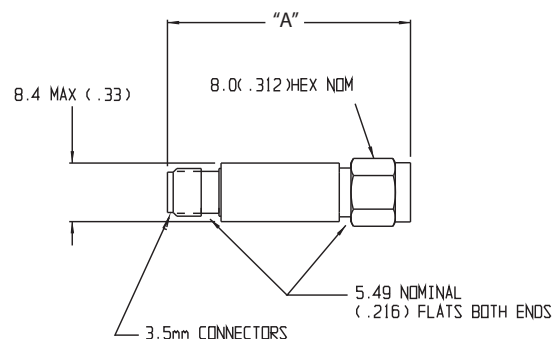

Model	DIM A
56	33.0±0.5 (1.300±0.02)
F56	35.9±0.5 (1.415±0.02)
M56	29.0±0.5 (1.140±0.02)

NOTE: All dimensions are given in mm (inches) and are maximum, unless otherwise specified.

MODEL NUMBER DESCRIPTION:

Example:

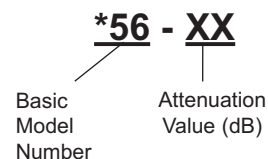

* Add Prefix M for double male and F for double female connectors.

ATTENUATOR SET (AS-20): Model 56 is also available in a Attenuator Set which includes five different attenuators (3, 6, 10, 20, 30 dB). Refer to Attenuator Sets data sheet for more information.

Fixed Coaxial Attenuators



Model 87 SMK Connectors

dc to 32.0 GHz
2 Watts



Features

- /// Available in 0.5 dB increments from 0-30 dB.
- /// Rugged injection molded connectors.
- /// Designed to meet environmental requirements of MIL-DTL-3933.
- /// New Lower Cost Commercial Version.

Specifications

NOMINAL IMPEDANCE: 50 Ω

FREQUENCY RANGE: dc to 32.0 GHz

MAXIMUM DEVIATION OVER FREQUENCY:

Nominal ATTN (dB)	Deviation (dB)
0	+ 0.5 / -0.0
0.5 - 12	± 0.50
12.5 - 20	± 1.00
20.5 - 30	± 2.00

MAXIMUM SWR:

Frequency (GHz)	SWR
dc - 32	1.25

POWER RATING: 2 watts **average** to 25°C ambient temperature, derated linearly to 0.5 watts at 100°C. 500 watts **peak** (5 μsec pulse width; 0.2% duty cycle).

POWER COEFFICIENT: < 0.005 dB/dB/watts

TEMPERATURE COEFFICIENT: < 0.0004 dB/dB/°C

TEMPERATURE RANGE: -55°C to +100°C

TEST DATA: Swept data plots of attenuation and SWR from 50 MHz to 32 GHz is available at additional cost.

CONNECTORS: SMK (2.92mm) connectors - mate non-destructively with SMA, 3.5mm and SMK (2.92mm) connectors.

CONSTRUCTION: Passivated stainless steel body and connectors; gold plated beryllium copper contacts.

WEIGHT: 8 g (0.28 oz)

PHYSICAL DIMENSIONS:

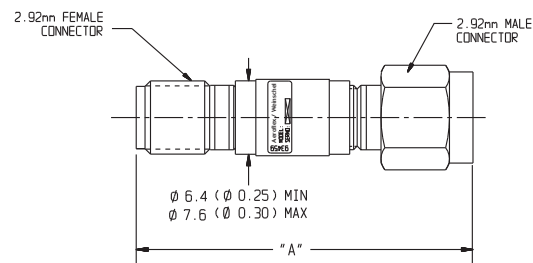

dB VALUE	DIM A ± 0.5 (0.02)
0-12	28.6 (1.15)
12.5-20	31.2 (1.23)
20.5-30	33.8 (1.33)

NOTE: All dimensions are given in mm (inches) and are maximum, unless otherwise specified.

MODEL NUMBER DESCRIPTION:

Example:

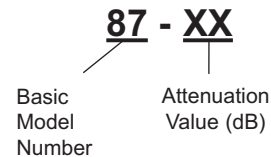

Model 84A Ruggedized 2.4mm Connectors

dc to 40.0 GHz
2 Watts

RoHS



Features

- /// Useable to 42 GHz.
- /// Designed to meet environmental requirements of MIL-DTL-3933.

Specifications

NOMINAL IMPEDANCE: 50 Ω
FREQUENCY RANGE: dc to 40.0 GHz

MAXIMUM DEVIATION OVER FREQUENCY:		
Nominal ATTN (dB)	Deviation (dB)	
	dc-26.5	26.5-40
3, 6, 10	± 0.50	± 1.00
20, 30	± 0.80	± 1.50

MAXIMUM SWR:	
Frequency (GHz)	SWR
dc - 26.5	1.25
26.5 - 40	1.45

POWER RATING: 2 watts **average** to 25 °C ambient temperature, derated linearly to 0.1 watt at 125 °C. 200 watts **peak** (5 μsec pulse width; 0.5 % duty cycle).

POWER COEFFICIENT: < 0.005 dB/dB/watts

TEMPERATURE COEFFICIENT: < 0.0004 dB/dB/°C

TEMPERATURE RANGE: -55°C to +125°C

TEST DATA: Swept data plots of attenuation and SWR from 50 MHz to 40 GHz is available at additional cost.

CONNECTORS: 2.4mm connectors mate nondestructively with other 2.4mm connectors. Contact Pin Recession (0 to 0.003)

CONSTRUCTION: Stainless steel body; gold plated beryllium copper contacts and brass connectors.

WEIGHT: 13 g (0.46 oz.) maximum

PHYSICAL DIMENSIONS:

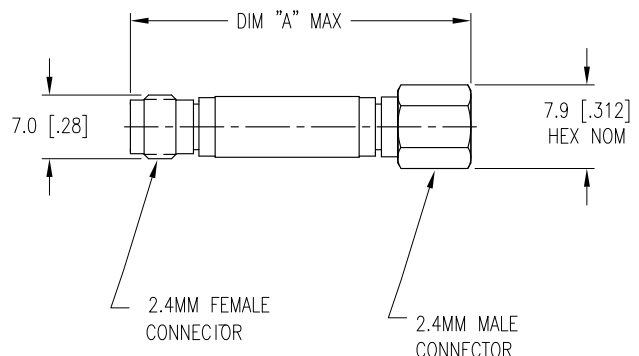

Model	DIM A
84A	38.10 (1.50)
F84A	34.00 (1.34)
M84A	42.20 (1.66)

NOTE: All dimensions are given in mm (inches) and are maximum, unless otherwise specified.

MODEL NUMBER DESCRIPTION:

Example:

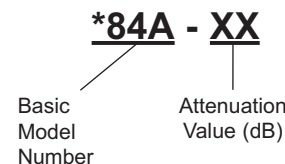

* Add Prefix M for double male and F for double female connectors.

Fixed Coaxial Attenuators



Model 54A SMK Connectors

dc to 40.0 GHz
2 Watts



Features

- Useable to 42 GHz.
- Designed to meet environmental requirements of MIL-DTL-3933.

Specifications

NOMINAL IMPEDANCE: 50 Ω
FREQUENCY RANGE: dc to 40.0 GHz

MAXIMUM DEVIATION OVER FREQUENCY:

Nominal ATTN (dB)	Deviation (dB)	
	dc-26.5	26.5-40
3, 6	± 0.50	± 1.00
10, 20, 30	± 0.80	± 1.50

MAXIMUM SWR:

Frequency (GHz)	SWR
dc - 26.5	1.25
26.5 - 40	1.45

POWER RATING: 2 watts **average** to 25 °C ambient temperature, derated linearly to 0.1 watt at 125 °C. 200 watts **peak** (5 μsec pulse width; 0.5 % duty cycle).

POWER COEFFICIENT: < 0.005 dB/dB/watts

TEMPERATURE COEFFICIENT: < 0.0004 dB/dB/°C

TEMPERATURE RANGE: -55 °C to +125 °C

TEST DATA: Swept data plots of attenuation and SWR from 50 MHz to 40 GHz is available at additional cost.

CONNECTORS: SMK (2.92mm) connectors - mate nondestructively with SMA, 3.5mm and SMK (2.92mm) connectors.

CONSTRUCTION: Stainless steel body and connectors; gold plated beryllium copper contacts.

WEIGHT: 13 g (0.46 oz.) maximum

PHYSICAL DIMENSIONS:

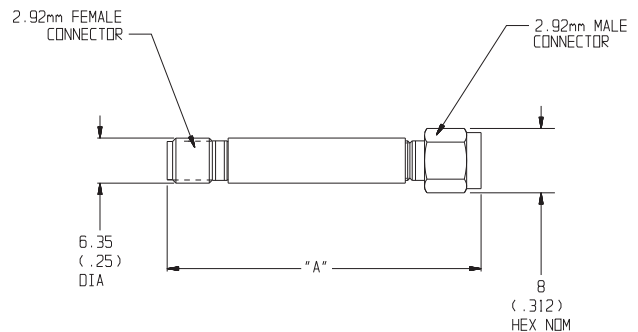

Model	DIM A
54A	39.9 (1.57)
F54A	37.9 (1.49)
M54A	42.0 (1.64)

NOTE: All dimensions are given in mm (inches) and are maximum, unless otherwise specified.

MODEL NUMBER DESCRIPTION:

Example:

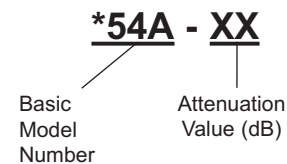

* Add Prefix M for double male and F for double female connectors.

Model 1W General Purpose, Type N

dc to 4.0 GHz
2 Watts



CONNECTORS: Type N (male/female) connectors - mate nondestructively with MIL-C-39012 connectors.

CONSTRUCTION: Nickel-plated brass body and connectors, gold plated Beryllium contacts

WEIGHT: 65 g (2.5 oz) maximum

PHYSICAL DIMENSIONS:

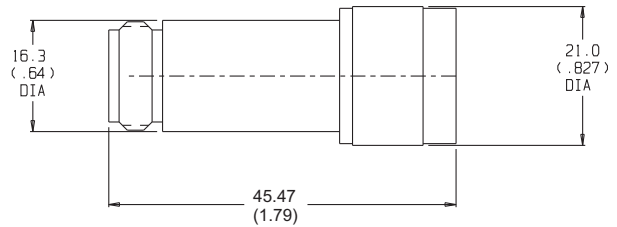

NOTE: All dimensions are given in mm (inches) and are maximum, unless otherwise specified.

MODEL NUMBER DESCRIPTION:

Example:

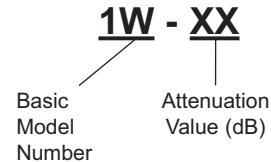

Features

- /// **Attenuation Values from 1 to 10, 20 dB.**
- /// **Low Cost**
- /// **Wireless Applications** - Optimized for use in the wireless communications bands.

Specifications

NOMINAL IMPEDANCE: 50 Ω

FREQUENCY RANGE: dc to 4.0 GHz

MAXIMUM DEVIATION OVER FREQUENCY:

Nominal ATTN (dB)	Deviation (dB)
1 -6	± 0.30
7 -10, 20	± 0.50

MAXIMUM SWR:

Frequency (GHz)	SWR
dc - 8.0	1.25

POWER RATING: 2 watts **average** to 25°C ambient temperature, derated linearly to 0.5 watts @ 105°C. 250 watts **peak** (5 μsec pulse width; 0.4% duty cycle).

POWER COEFFICIENT: < 0.005 dB/dB/watt

TEMPERATURE COEFFICIENT: < 0.0004 dB/dB/°C

TEMPERATURE RANGE: -20°C to +105°C.

Fixed Coaxial Attenuators



Model 55 TNC Connectors

dc to 18.0 GHz
5 Watts



Features

- /// **Quality TNC Connectors** - This Attenuator incorporates an improved 18 GHz TNC connector design standardized through the IEC.
- /// **Designed to meet environmental requirements of MIL-DTL-3933.**

Specifications

NOMINAL IMPEDANCE: 50 Ω

FREQUENCY RANGE: dc to 18.0 GHz

MAXIMUM DEVIATION OVER FREQUENCY:

Nominal ATTN (dB)	Deviation (dB)
1 - 6	± 0.40
7 -10, 20	± 0.50
30	± 0.90

MAXIMUM SWR:

Frequency (GHz)	SWR
dc - 4	1.15
4 - 8	1.20
8 - 12.4	1.25
12.4 - 18	1.35

POWER RATING: 5 watts **average** @ 25°C ambient temperature, derated linearly to 0.5 watt @ 125°C. 1 kilowatt **peak** (5 μsec pulse width; 0.25% duty cycle)

POWER COEFFICIENT: < 0.005 dB/dB/watt

TEMPERATURE COEFFICIENT: < 0.0004 dB/dB/ °C

TEMPERATURE RANGE: -55°C to +125°C

TEST DATA: Swept data plots of attenuation and SWR from 50 MHz to 18 GHz is available at additional cost.

CONNECTORS: TNC connectors per MIL-STD-348 interface dimensions - mate nondestructively with MIL-C-39012 connectors.

CONSTRUCTION: Stainless steel body and connectors; gold plated beryllium copper contacts.

WEIGHT: 28 g (1 oz) maximum

PHYSICAL DIMENSIONS:

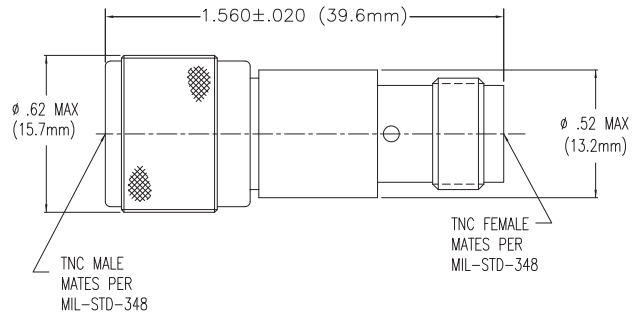

NOTE: All dimensions are given in mm (inches) and are maximum, unless otherwise specified.

MODEL NUMBER DESCRIPTION:

Example:

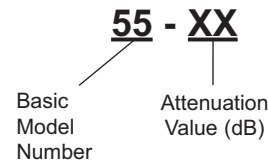

Model 1 Model 2 Precision N Connectors

dc to 12.4 GHz
dc to 18.0 GHz
5 Watts

RoHS



Features

- /// Rugged injection molded connectors.
- /// Designed to meet environmental requirements of MIL-DTL-3933.

Specifications

NOMINAL IMPEDANCE: 50 Ω

FREQUENCY RANGE: Model 1: dc to 12.4 GHz
Model 2: dc to 18.0 GHz

MAXIMUM DEVIATION OVER FREQUENCY:		
Nominal ATTN (dB)	1	2
1-9	± 0.30	± 0.30
10, 20	± 0.30	± 0.50
30, 40	± 0.75	± 1.00
50	± 0.75	± 1.25
60	± 1.00	± 1.50

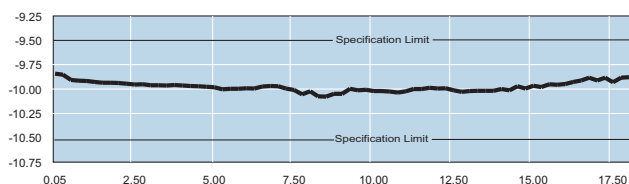

Typical Attenuation Performance of Model 2-10

MAXIMUM SWR:		
Frequency (GHz)	1	2
dc - 4	1.15	1.15
4 - 8	1.20	1.20
8 - 12.4	1.25	1.25
12.4 - 18	---	1.35

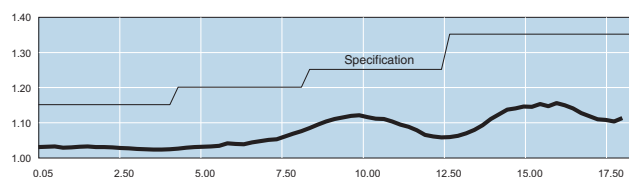

Typical SWR of Model 2-10

POWER RATING: 5 watts **average** @ 25°C ambient temperature, derated linearly to 0.5 watt @ 125°C. 1 kilowatt **peak** (5 μsec pulse width; 0.25% duty cycle)

POWER COEFFICIENT: <0.005 dB/dB/Watt

TEMPERATURE COEFFICIENT: < 0.0004 dB/dB/°C

TEMPERATURE RANGE: -55°C to +125°C

TEST DATA: Swept data plots of attenuation and SWR from 50 MHz to 12.4 / 18 GHz is available at additional cost.

CONNECTORS: Precision Type N connectors per MIL-STD-348 interface dimensions - mate nondestructively with MIL-C-39012 connectors.

CONSTRUCTION: Stainless steel body and connectors; gold plated beryllium copper contacts.

WEIGHT:

dB VALUE	WEIGHT (Net)
1 - 10, 20, 30	71 g (2.5 oz)
40, 50, 60	79 g (2.8 oz)

PHYSICAL DIMENSIONS:

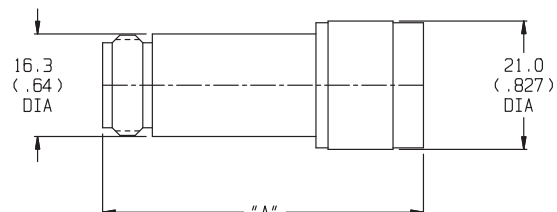

dB VALUE	DIM A
1-10, 20, 30	57.9 (2.28)
40, 50, 60	68.1 (2.68)

NOTE: All dimensions are given in mm (inches) and are maximum, unless otherwise specified.

MODEL NUMBER DESCRIPTION:

Example:

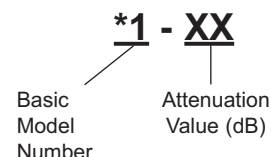

*Add Prefix M for double male or F for double female connectors.

ATTENUATOR SET (AS-6): Model 2 is also available in a Attenuator Set which includes four different attenuators (3, 6, 10, 20 dB). Refer to Attenuator Sets data sheet for more information.

Fixed Coaxial Attenuators



Model 44 Lab Standard, Precision N Connectors

dc to 18.0 GHz
5 Watts



Features

- /// Precision Connectors
- /// Test data - A certificate of test supplied with each attenuator.
- /// Hex Nut Connector - Allows for use of a torque wrench to improve connector repeatability.
- /// Designed to meet environmental requirements of MIL-DTL-3933.

Specifications

NOMINAL IMPEDANCE: 50 Ω

FREQUENCY RANGE: dc to 18.0 GHz

MAXIMUM DEVIATION OVER FREQUENCY:

Nominal ATTN (dB)	Deviation (dB)
1 - 9	± 0.30
10, 20	± 0.50
30, 40	± 1.00
50	± 1.25
60	± 1.50

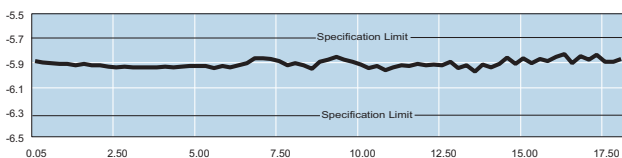

Typical Attenuation Accuracy of a 44-6

MAXIMUM SWR:

Frequency (GHz)	SWR
dc - 4	1.15
4 - 12.4	1.20
12.4 - 18	1.25

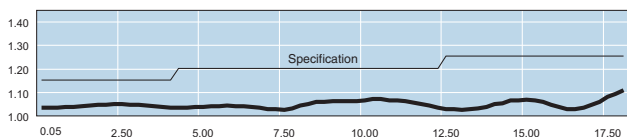

Typical SWR of a 44-6

POWER RATING: 5 watts **average** @ 25°C ambient temperature, derated linearly to 0.5 watt @ 125°C. 1 kilowatt **peak** (5 μsec pulse width; 0.25% duty cycle)

POWER COEFFICIENT: <0.005 dB/dB/Watt

TEMPERATURE COEFFICIENT: < 0.0004 dB/dB/°C

TEMPERATURE RANGE: -55°C to +125°C

TEST DATA: Swept data plots of attenuation and SWR from 50 MHz to 18 GHz.

CONNECTORS: Precision Type N per MIL-STD-348 interface dimensions - mate nondestructively with MIL-C-39012 connectors. Coupling Torque: 14 ± 1 in/lbs.

CONSTRUCTION: Brass Body (plated) and Stainless steel connectors; gold plated beryllium copper contacts.

WEIGHT:

dB VALUE	WEIGHT (Net)
1 - 10, 20, 30	100 g (3.5 oz)
40, 50, 60	140 g (4.5 oz)

PHYSICAL DIMENSIONS:

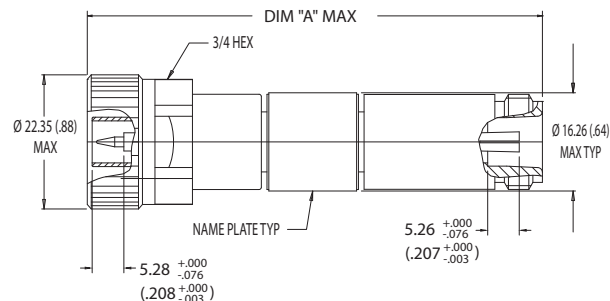

dB VALUE	Prefix M	DIM A STD	Prefix F
0-10, 20, 30	76.2 (3.0)	76.2 (3.0)	77.7 (3.06)
40, 50, 60	86.4 (3.4)	86.4 (3.4)	87.9 (3.46)

NOTE: All dimensions are given in mm (inches) and are maximum, unless otherwise specified.

MODEL NUMBER DESCRIPTION:

Example:

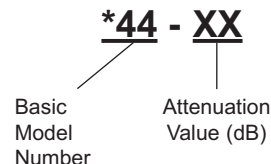

*Add Prefix M for double male or F for double female connectors.

ATTENUATOR SET (AS-18): Model 44 is also available in a Attenuator Set which includes six different attenuators (1, 3, 6, 10, 20, 30 dB). Refer to Attenuator Sets data sheet for more information.

Model 69A Bi-directional Design, SMA Connectors

dc to 18.0 GHz
5 Watts



Features

- /// Compact Construction - Lowest size/power ratio.
- /// Precision Injection Molded Connectors
- /// Designed to meet environmental requirements of MIL-DTL-3933.
- /// Flat Response & Low SWR.

Specifications

NOMINAL IMPEDANCE: 50 Ω
FREQUENCY RANGE: dc to 18.0 GHz

MAXIMUM DEVIATION OVER FREQUENCY:

Nominal ATTN (dB)	Deviation (dB)
1 - 6	± 0.30
7 - 10, 20, 30	± 0.50

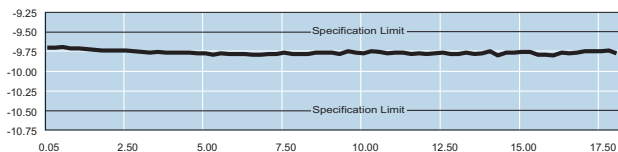

Typical Attenuation Accuracy of a 69A-10

MAXIMUM SWR:

Frequency (GHz)	SWR
dc - 8	1.15
8 - 18	1.25

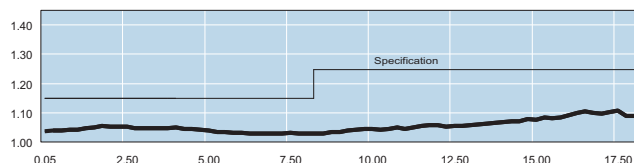

Typical SWR of a 69A-10

POWER RATING (mounted horizontally): 5 watts average (bi-directional) to 25°C ambient temperature, derated linearly to 0.5 Watt @ 125°C. 500 watts peak (5 μsec pulse width; 0.5% duty cycle).

POWER COEFFICIENT: <0.003 dB/dB/watt

TEMPERATURE COEFFICIENT: <0.0004 dB/dB/°C

TEMPERATURE RANGE: -55 °C to 125 °C

TEST DATA: Swept data plots of attenuation and SWR from 50 MHz to 18 GHz is available at additional cost.

CONNECTORS: SMA connectors per MIL-STD-348 interface dimensions - mate nondestructively with SMK, 3.5mm, 2.92mm and SMA connectors per MIL-C-39012 .

Connector Options	Type/Description
1	SMA, Female
2	SMA, Male

CONSTRUCTION: Black, finned aluminum body, stainless steel connectors; gold plated beryllium copper contacts.

WEIGHT: Net 10 g (0.35 oz) maximum

PHYSICAL DIMENSIONS:

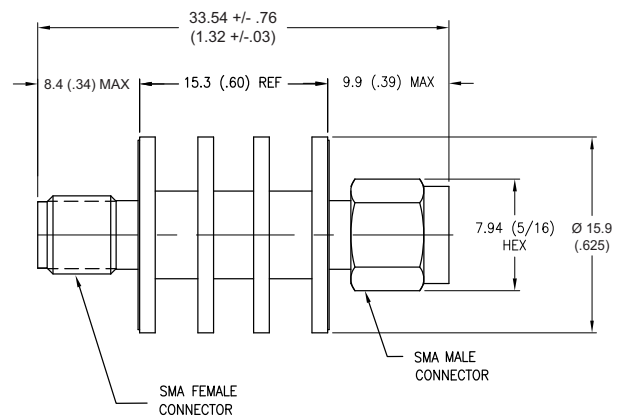

NOTE: All dimensions are given in mm (inches) and are maximum, unless otherwise specified.

MODEL NUMBER DESCRIPTION:

Example:

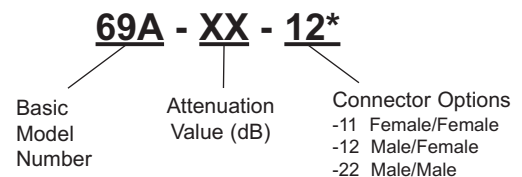

*Unit is bi-directional and full power may be applied to either connector.

Fixed Coaxial Attenuators



Model 75A Bi-directional Design, SMK Connectors

dc to 40.0 GHz
5 Watts



Features

- /// Usable to 42 GHz
- /// Compact Construction - Lowest size/power ratio.
- /// Precision Injection Molded Connectors
- /// Designed to meet environmental requirements of MIL-DTL-3933.
- /// Flat Response & Low SWR

Specifications

NOMINAL IMPEDANCE: 50 Ω

FREQUENCY RANGE: dc to 40.0 GHz

MAXIMUM DEVIATION OVER FREQUENCY:

Nominal ATTN (dB)	Deviation (dB)	
	dc-26.5 GHz	26.5-40 GHz
3, 6	± 0.50	± 1.00
10, 20, 30	± 0.80	± 1.50

MAXIMUM SWR:

Frequency (GHz)	SWR
dc - 26.5	1.25
26.5 - 40	1.45

POWER RATING (mounted horizontally): 5 watts **average (bi-directional)** to 25°C ambient temperature, derated linearly to 0.5 Watt @ 125°C. 200 watts **peak** (5 μsec pulse width; 1.25% duty cycle).

POWER COEFFICIENT: <0.002 dB/dB/watt

TEMPERATURE COEFFICIENT: <0.0004 dB/dB/°C

TEMPERATURE RANGE: -55 °C to 125 °C

TEST DATA: Swept data plots of attenuation and SWR from 50 MHz to 40 GHz.

CONNECTORS: SMK (2.92mm) Male/Female connectors - mate nondestructively with SMA, 3.5mm and SMK (2.92mm) connectors.

Connector Options	Type/Description
1	2.92mm, Female
2	2.92mm, Male

CONSTRUCTION: Black, finned aluminum body, gold plated beryllium copper contacts.

WEIGHT: 200 g (7.0 oz.) maximum

PHYSICAL DIMENSIONS:

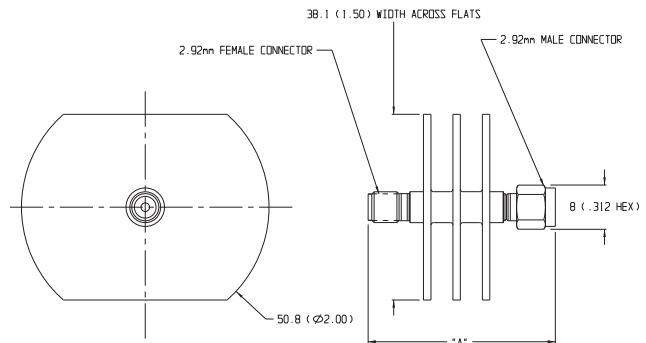

Dash No.	Connector Type	DIM A
11	2.92mm Female/Female	39.9 (1.56)
12	2.92mm Male/Female	44.1 (1.74)
22	2.92mm Male/Male	48.8 (1.92)

NOTE: All dimensions are given in mm (inches) and are nominal, unless otherwise specified.

MODEL NUMBER DESCRIPTION:

Example:

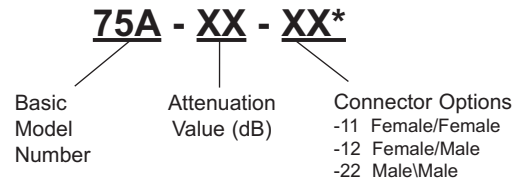

*Unit is bi-directional and full power may be applied to either connector.

Attenuator Sets

dc to 18.0/26.5 GHz



Model AS-6
(Type N)



Model AS-18
(Precision Type N)



Model AS-20
(3.5mm)

Features

- /// **Test Data:** Test Data for each attenuator is provided.
- /// **Data furnished:** AS-6 and AS-18, Insertion loss & SWR ports 1 and 2 test data supplied at 0.05, 4.0, 8.0, 12.4 and 18.0 GHz and AS-20, Insertion loss & SWR ports 1 and 2 test data supplied at 0.05, 4.0, 8.0, 12.4, 18.0 and 28.0GHz.
- /// **Wide Temperature Range:** -55 °C to 100 °C. Full rated power to 25 °C. Derated Linearity to 0.5 watts @ 125 °C.
- /// **Uniform Phase Characteristics:** Excellent unit-to-unit tracking and phase linearly with frequency.
- /// **Rugged Construction:** Designed to meet all environmental requirements of MIL-DTL-3933.
- /// **High Repeatability Connectors:**
 - AS-6: Type N per MIL-STD-348
 - AS-18: Precision N per MIL-STD-348
 - AS-20: Precision 3.5mm
- /// **Durable Storage Case.**

Specifications

Set Model Number	Standard Model Number	Nominal Values (dB)	Frequency Range (GHz)	Average Power (W)	Connector Type	Maximum* SWR	Page No.**
AS-6	2	3, 6, 10, 20	dc-18 GHz	5	N	1.15 - 1.35	36
AS-18	44	1, 3, 6, 10, 20, 30	dc-18 GHz	5	N	1.15 - 1.25	37
AS-20	56	3, 6, 10, 20, 30	dc-26.5 GHz	2	3.5mm	1.10 - 1.25	30

*Varies with frequency.

**Refer to indicated page for more detailed attenuator specifications.

STORAGE CASE DIMENSIONS:

- Model AS-6: 136.5mm (5-3/8 in) long x 125.4mm (4-15/16 in) wide x 35.6mm (2-3/16 in) high
- Model AS-18: 215.9mm (8.5 in) long x 273mm (10-3/4 in) wide x 63.5mm (2-1/2 in) high
- Model AS-20: 139.7mm (5-1/2 in) long x 123.8mm (4-7/8 in) wide x 60.3mm (2-3/8 in) high

Fixed Coaxial Attenuators







High Reliability Attenuators

Designed to meet requirements of MIL-DTL-3933, CLASS III/IV, N/S

dc to 18.0 GHz
2 to 25 Watts



Basic Model Information...

Part Number	Description	Outline Drawing/ Dimensions	
272N-XX (Non-screened) 272S-XX (Screened) (Available in 1- 10, 20 , 30 & 40 dB)	dc to 18 GHz 5 watts Average; 1 kW peak	Refer to Aeroflex / Weinschel Standard Model 272 (page 41a) for specifications.	
273N-XX (Non-screened) 273S-XX (Screened) (Available in 0 - 10 in 0.5 dB steps, 11- 20 in 1 dB steps & 25 - 40 in 5 dB steps)	dc to 18 GHz 2 watts Average; 500 W peak	Refer to Aeroflex / Weinschel Standard Model 273 (page 41b) for specifications.	
274N-XX (Non-screened) 274S-XX (Screened) (Available in 0 - 20 in 0.5 dB steps, 30, & 40 dB)	dc to 18 GHz 2 watts Average; 500 W peak	Refer to Aeroflex / Weinschel Standard Model 274 (page 41c) for specifications.	
276N-XX (Non-screened) 276S-XX (Screened) (Available in 3, 6, 10, 20, 30 dB)	dc to 18 GHz 25 Watts Average; 2 kW peak	Refer to Aeroflex / Weinschel Standard Model 276 (page 41d) for specifications.	

Features

- /// Screened and Non-screened models available.
- /// Choice of attenuation values from 0 to 40 dB.
- /// Frequency Ranges from dc to 18 GHz.
- /// Power capability from 2 to 25 watts.
- /// Test Data supplied at additional cost as follows:
 - Non-screened (N):** Swept data plots of Attenuation and SWR across the frequency band.
 - Screened (S):** Swept data plots of Attenuation and SWR across the frequency band. Film, Standard data package includes lot record performance showing pass/fail quantities for all tests and test reports as applicable.
- /// Type N and SMA Connectors.

Screening

Units are screened as follows:

"N" versions:

- SWR
- Attenuation
- Peak Power

"S" versions:

- Thermal Shock
- Monitored Thermal Cycle (MTC)
- Attenuation w/Parts Assembly Verification (PAV)
- Conditioning
- Peak Power
- Attenuation
- SWR
- Radiographics

MODEL NUMBER DESCRIPTION:

Example:

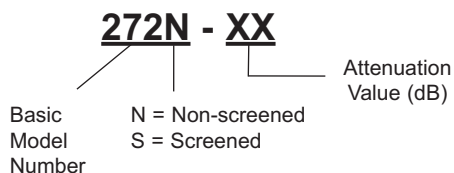

Model 272 High Reliability, N Connectors

dc to 18.0 GHz

2 Watts



Designed to meet requirements of
MIL-DTL-3933, CLASS III/IV, N/S



Features

- /// Rugged injection molded connectors.
- /// Screened (Model 272S) and Non-screened (Model 272N) designs available.
- /// Available in 1- 10, 20, 30 & 40 dB.
- /// Test Data supplied at additional cost as follows:
Non-screened (N): Swept data plots of Attenuation and SWR across the frequency band.
Screened (S): Swept data plots of Attenuation and SWR across the frequency band. Film, Standard data package includes lot record performance showing pass/fail quantities for all tests and test reports as applicable.

Specifications

NOMINAL IMPEDANCE: 50 Ω

FREQUENCY RANGE: dc to 18.0 GHz

MAXIMUM DEVIATION OVER FREQUENCY:

Nominal ATTN (dB)	dB
1 - 6.5	± 0.30
7 - 8.5	± 0.40
9 - 14	± 0.50
15 - 20	± 0.60
21 - 40	± 1.00

MAXIMUM SWR:

Frequency (GHz)	SWR
dc - 4	1.12
4 - 8	1.15
8 - 12.4	1.18
12.4 - 18	1.20

POWER RATING: 5 watts **average** @ 25°C ambient temperature, derated linearly to 0.5 watt @ 125°C. 1 kilowatt **peak** (5 μsec pulse width; 0.25% duty cycle)

POWER COEFFICIENT: <0.005 dB/dB/Watt

TEMPERATURE COEFFICIENT: < 0.0004 dB/dB/°C

TEMPERATURE RANGE: -55°C to +125°C

CONNECTORS: Precision Type N connectors per MIL-STD-348 interface dimensions - mate nondestructively with MIL-C-39012 connectors.

CONSTRUCTION: Stainless steel body and connectors; gold plated beryllium copper contacts.

WEIGHT:

dB VALUE	WEIGHT (Net)
1 - 10, 20, 30	70 g (2.6 oz)
40	100 g (3.6 oz)

PHYSICAL DIMENSIONS:

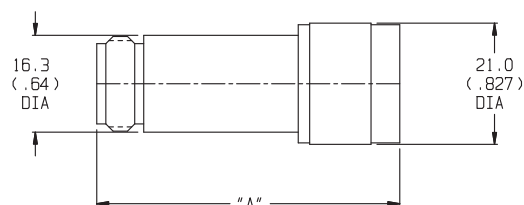

dB VALUE	DIM A
1-10, 20, 30	57.9 (2.28)
40	68.1 (2.68)

NOTE: All dimensions are given in mm (inches) and are maximum, unless otherwise specified.

Screening

Units are screened as follows:

"N" versions:

- SWR
- Attenuation
- Peak Power

"S" versions:

- Thermal Shock
- Monitored Thermal Cycle (MTC)
- Attenuation
- Conditioning
- Peak Power
- Attenuation
- SWR
- Radiographics

MODEL NUMBER DESCRIPTION:

Example:

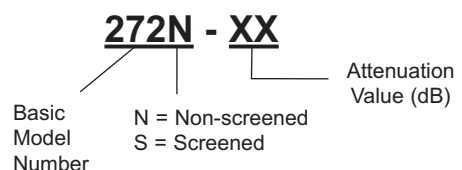

Fixed Coaxial Attenuators



Model 273 High Reliability, SMA Connectors

dc to 18.0 GHz

2 Watts



Designed to meet requirements of MIL-DTL-3933, CLASS III/IV, N/S



Features

- /// Rugged injection molded connectors.
- /// Screened (Model 273S) and Non-screened (Model 273N) designs available.
- /// Available in 0-10 in 0.5 dB steps, 11- 20 in 1 dB steps & 25 - 40 in 5 dB steps.
- /// Test Data supplied at additional cost as follows:
Non-screened (N): Swept data plots of Attenuation and SWR across the frequency band.
Screened (S): Swept data plots of Attenuation and SWR across the frequency band. Film, Standard data package includes lot record performance showing pass/fail quantities for all tests and test reports as applicable.

Specifications

NOMINAL IMPEDANCE: 50 Ω

FREQUENCY RANGE: dc to 18.0 GHz

MAXIMUM DEVIATION OVER FREQUENCY:

Nominal ATTN (dB)	dB
0 - 6.5	± 0.30
7 - 8.5	± 0.40
9 - 14	± 0.50
15 - 20	± 0.60
25 - 40	± 1.00

MAXIMUM SWR:

Frequency (GHz)	SWR
dc - 2	1.10
2 - 4	1.15
4 - 8	1.20
8 - 12.4	1.25
12.4 - 18	1.35

POWER RATING: 2 watts **average** to 25°C ambient temperature, derated linearly to 0.5 watts at 125°C. 500 watts **peak** (5 μsec pulse width; 0.2% duty cycle).

POWER COEFFICIENT: < 0.005 dB/dB/watts

TEMPERATURE COEFFICIENT: < 0.0004 dB/dB/°C

TEMPERATURE RANGE: -55°C to +125°C

CONNECTORS: SMA connectors per MIL-STD-348 interface dimensions - mate nondestructively with MIL-C-39012 connectors.

CONSTRUCTION: Passivated stainless steel body and connectors; gold plated beryllium copper contacts.

WEIGHT:

dB VALUE	WEIGHT (Net)
1 - 12	3.9 g (0.14 oz)
13 - 20	4.3 g (0.15 oz)
25 - 30	6.5 g (0.23 oz)
35 - 40	12.8 g (0.45 oz)

PHYSICAL DIMENSIONS:

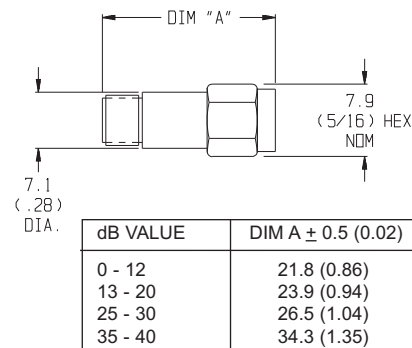

NOTE: All dimensions are given in mm (inches) and are maximum, unless otherwise specified.

Screening

Units are screened as follows:

"N" versions:

- SWR
- Attenuation
- Peak Power

"S" versions:

- Thermal Shock
- Monitored Thermal Cycle (MTC)
- Attenuation w/Parts Assembly Verification (PAV)
- Conditioning
- Peak Power
- Attenuation
- SWR
- Radiographics

MODEL NUMBER DESCRIPTION:

Example:

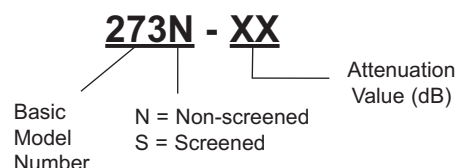

Model 274 High Reliability, SMA Connectors

dc to 18.0 GHz
2 Watts



Designed to meet requirements of
MIL-DTL-3933, CLASS III/IV, N/S



Features

- /// Rugged injection molded connectors.
- /// Screened (Model 274S) and Non-screened (Model 274N) designs available.
- /// Available in 0 - 20 in 0.5 dB steps, 30 & 40 dB.
- /// Test Data supplied at additional cost as follows:
 - Non-screened (N):** Swept data plots of Attenuation and SWR across the frequency band.
 - Screened (S):** Swept data plots of Attenuation and SWR across the frequency band. Film, Standard data package includes lot record performance showing pass/fail quantities for all tests and test reports as applicable.

Specifications

NOMINAL IMPEDANCE: 50 Ω

FREQUENCY RANGE: dc to 18.0 GHz

MAXIMUM DEVIATION OVER FREQUENCY:

Nominal ATTN (dB)	dB
0 - 2	± 0.50
3 - 6	± 0.30
7 - 12	± 0.50
20	± 0.70
30, 40	± 1.00

MAXIMUM SWR:

Frequency (GHz)	SWR
dc - 4	1.15
4 - 8	1.20
8 - 12.4	1.25
12.4 - 18	1.35

POWER RATING: 2 watts **average** to 25°C ambient temperature, derated linearly to 0.5 watts at 125°C. 500 watts **peak** (5 μsec pulse width; 0.2% duty cycle).

POWER COEFFICIENT: < 0.005 dB/dB/watts

TEMPERATURE COEFFICIENT: < 0.0004 dB/dB/°C

TEMPERATURE RANGE: -55°C to +125°C

CONNECTORS: SMA connectors per MIL-STD-348 interface dimensions - mate nondestructively with MIL-C-39012 connectors.

CONSTRUCTION: Passivated stainless steel body and connectors; gold plated beryllium copper contacts.

WEIGHT:

dB VALUE	WEIGHT (Net)
1 - 20	10 g (0.35 oz)
30, 40	20 g (0.70 oz)

PHYSICAL DIMENSIONS:

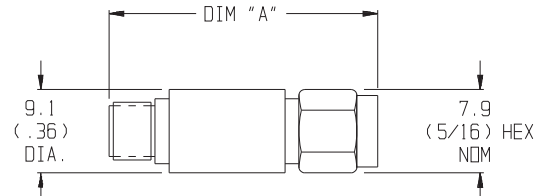

dB VALUE	DIM A ± 0.5 (0.02)		
	STD	Prefix F	Prefix M
1 - 10, 20	30.5 (1.20)	29.7 (1.17)	32.3 (1.27)
30, 40	47.0 (1.85)	46.2 (1.82)	47.7 (1.88)

NOTE: All dimensions are given in mm (inches) and are maximum, unless otherwise specified.

Screening

Units are screened as follows:

"N" versions:

- SWR
- Attenuation
- Peak Power

"S" versions:

- Thermal Shock
- Monitored Thermal Cycle (MTC)
- Attenuation w/Parts Assembly Verification (PAV)
- Conditioning
- Peak Power
- Attenuation
- SWR
- Radiographics

MODEL NUMBER DESCRIPTION:

Example:

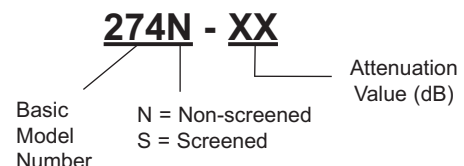

Model 276 High Reliability, N Connectors

dc to 18.0 GHz
25 Watts



Designed to meet requirements of
MIL-DTL-3933, CLASS III/IV, N/S



Features

- /// Rugged injection molded connectors.
- /// Screened (Model 276S) and Non-screened (Model 276N) designs available.
- /// Available in 3, 6, 10, 20 & 30 dB.
- /// Test Data supplied at additional cost as follows:
Non-screened (N): Swept data plots of Attenuation and SWR across the frequency band.
Screened (S): Swept data plots of Attenuation and SWR across the frequency band. Film, Standard data package includes lot record performance showing pass/fail quantities for all tests and test reports as applicable.

Specifications

NOMINAL IMPEDANCE: 50 Ω

FREQUENCY RANGE: dc to 18.0 GHz

MAXIMUM DEVIATION OVER FREQUENCY:

Nominal ATTN (dB)	dB
3, 6	± 0.30
10, 20	± 0.50
30	± 1.00

MAXIMUM SWR:

Frequency (GHz)	SWR
dc - 4	1.15
4 - 8	1.20
8 - 12	1.25
12 - 18	1.40

POWER RATING (mounted horizontally): 25 watts average (bi-directional) to 25°C ambient temperature, derated linearly to 2.5 watts @ 125°C.

3, 6 dB: 1 kilowatt **peak** (5 μsec pulse width; 0.05% duty cycle), 10, 20 30 dB: 2 kilowatt **peak** (5 μsec pulse width; 0.05% duty cycle).

POWER COEFFICIENT: <0.0006 dB/dB/watt

TEMPERATURE COEFFICIENT: <0.0004 dB/dB/°C

TEMPERATURE RANGE: -55°C to 125°C

CONNECTORS: Type N connectors per MIL-STD-348 interface dimensions - mate nondestructively with MIL-C-39012 connectors.

Options	Description
3	Type N Female
4	Type N Male

CONSTRUCTION: Black, finned aluminum body, stainless steel connectors with gold plated beryllium copper contacts.

WEIGHT: 110 g (4 oz.) maximum

PHYSICAL DIMENSIONS:

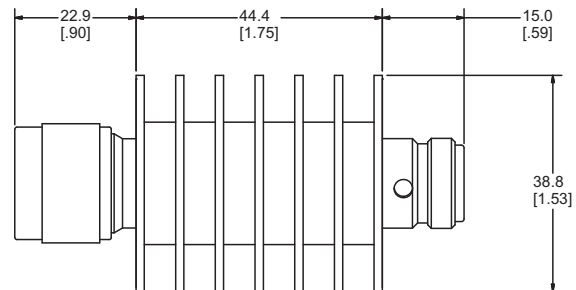

Connector	DIM A
N Male	24.1 (0.95)
N Female	19.0 (0.75)

NOTE: All dimensions are given in mm (inches) and are maximum, unless otherwise specified.

Screening

Units are screened as follows:

"N" versions:

- SWR
- Attenuation
- Peak Power

"S" versions:

- Thermal Shock
- Monitored Thermal Cycle (MTC)
- Attenuation
- Conditioning
- Peak Power
- Attenuation
- SWR
- Radiographics

MODEL NUMBER DESCRIPTION:

Example:

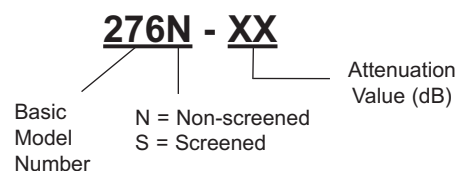

Model 32 High Reliability, SMA Connectors Suitable for Space & Airborne Applications

dc to 18.0 GHz

2 Watts



Features

- /// Available in 0.5 dB increments from 0-20 dB.
- /// Precision injection molded connectors.
- /// Designed to meet environmental requirements of MIL-DTL-3933.
- /// 100% Subjected to Thermal Shock, Peak Power & Monitored Thermal Cycle (MTC).

Specifications

NOMINAL IMPEDANCE: 50 Ω

FREQUENCY RANGE: dc to 18.0 GHz

MAXIMUM DEVIATION OVER FREQUENCY:

Nominal ATTN (dB)	Deviation (dB)
0	+ 0.30
0.5 - 6	± 0.30
6.5 - 12	± 0.50
12.5 - 20	± 0.70

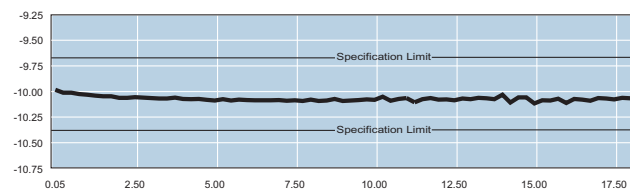

Typical Attenuation Accuracy of 32-10

MAXIMUM SWR:

Frequency (GHz)	SWR
dc - 4	1.15
4 - 8	1.20
8 - 12.4	1.25
12.4 - 18	1.35

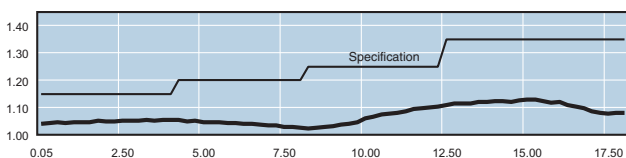

Typical SWR of a 32-10

POWER RATING: 2 watts **average** to 25°C ambient temperature, derated linearly to 0.5 watts at 125°C. 500 watts **peak** (5 μsec pulse width; 0.2% duty cycle).

POWER COEFFICIENT: < 0.005 dB/dB/watts

TEMPERATURE COEFFICIENT: < 0.0004 dB/dB/°C

TEMPERATURE RANGE: -55°C to +125°C

CONNECTORS: SMA connectors per MIL-STD-348 interface dimensions - mate nondestructively with MIL-C-39012 connectors.

CONSTRUCTION: Passivated stainless steel body and connectors; gold plated beryllium copper contacts. Each unit is sealed using low outgassing sealant.

WEIGHT:

dB VALUE	WEIGHT (Net)
0 - 12	3.9 g (0.14 oz)
12.5 - 20	4.3 g (0.15 oz)

PHYSICAL DIMENSIONS:

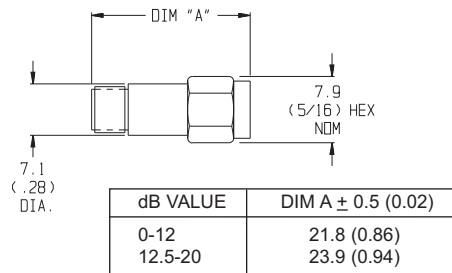

NOTE: All dimensions are given in mm (inches) and are maximum, unless otherwise specified.

Screening

Units are screened 100% as follows:

Thermal Shock: 10 cycles, -55°C to +100°C

Peak Power: 200 Watts, 5 μsec pulse width; 0.05% duty cycle for 3 minutes at each end. DC Attenuation is measured before and after peak power.

Monitored Thermal Cycle: Units are subjected to 10 thermal cycles between -55 °C to +100 °C. The PIN-to-PIN DC resistance is continuously monitored and stored.

Attenuation and SWR are tested as final electrical test.

MODEL NUMBER DESCRIPTION:

Example:

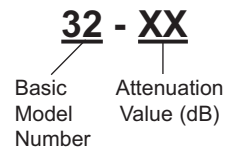

EXPORT CONTROL:

This product is controlled for export under the International Traffic in Arms Regulations (ITAR). A license from the U.S. Department of State is required prior to the export of this product from the United States.

EXPORT WARNING:

Aeroflex's military and space products are controlled for export under the International Traffic in Arms Regulations (ITAR) and may not be sold or proposed or offered for sale to certain countries. (See ITAR 126.1 for complete information.)

Fixed Coaxial Attenuators



Models 32J High Reliability, SMK Connectors Suitable for Space & Airborne Applications

dc to 32.0 GHz
2 Watts



Features

- /// Available in 0.5 dB increments from 0-30 dB.
- /// Rugged injection molded connectors.
- /// Designed to meet environmental requirements of MIL-DTL-3933.
- /// 100% Subjected to Thermal Shock, Peak Power & Monitored Thermal Cycle (MTC).

Specifications

NOMINAL IMPEDANCE: 50 Ω

FREQUENCY RANGE: dc to 32.0 GHz

MAXIMUM DEVIATION OVER FREQUENCY:

Nominal ATTN (dB)	Deviation (dB)
0	+ 0.5 / -0.0
0.5 - 12	± 0.50
12.5 - 20	± 1.00
20.5 - 30	± 2.00

MAXIMUM SWR:

Frequency (GHz)	SWR
dc - 32	1.25

POWER RATING: 2 watts **average** to 25°C ambient temperature, derated linearly to 0.5 watts at 100°C. 500 watts **peak** (5 μsec pulse width; 0.2% duty cycle).

POWER COEFFICIENT: < 0.005 dB/dB/watts

TEMPERATURE COEFFICIENT: < 0.0004 dB/dB/°C

TEMPERATURE RANGE: -55°C to +100°C

CONNECTORS: SMK (2.92mm) connectors - mate nondestructively with SMA, 3.5mm and SMK (2.92mm) connectors.

CONSTRUCTION: Passivated stainless steel body and connectors; gold plated beryllium copper contacts. Each unit is sealed using low outgassing sealant.

WEIGHT: 13 g (0.46 oz)

PHYSICAL DIMENSIONS:

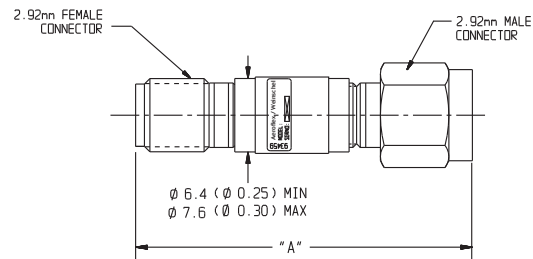

dB VALUE	DIM A ± 0.5 (0.02)
0-12	28.6 (1.15)
12.5-20	31.2 (1.23)
20.5-30	33.8 (1.33)

NOTE: All dimensions are given in mm (inches) and are maximum, unless otherwise specified.

Screening

Units are screened 100% as follows:

Thermal Shock: 10 cycles, -55°C to +100°C

Peak Power: 200 Watts, 5 μsec pulse width; 0.05% duty cycle for 3 minutes at each end. DC Attenuation is measured before and after peak power.

Monitored Thermal Cycle: Units are subjected to 10 thermal cycles between -55 °C to +100 °C. The PIN-to-PIN DC resistance is continuously monitored and stored.

Attenuation and SWR are tested as final electrical test.

MODEL NUMBER DESCRIPTION:

Example:

32J - XX

Basic Model Number Attenuation Value (dB)

EXPORT CONTROL:

This product is controlled for export under the International Traffic in Arms Regulations (ITAR). A license from the U.S. Department of State is required prior to the export of this product from the United States.

EXPORT WARNING:

Aeroflex's military and space products are controlled for export under the International Traffic in Arms Regulations (ITAR) and may not be sold or proposed or offered for sale to certain countries. (See ITAR 126.1 for complete information.)

Model 32K High Reliability, SMK Connectors Suitable for Space & Airborne Applications

dc to 40.0 GHz
2 Watts



Features

- /// Usable to 42 GHz.
- /// Ideal for Space & Airborne Applications.
- /// Available in 3, 6, 10, 20 & 30 dB. Other values available upon request.
- /// Precision injection molded connectors.
- /// Designed to meet environmental requirements of MIL-DTL-3933.
- /// 100% Subjected to Thermal Shock, Peak Power & Monitored Thermal Cycle (MTC).

Specifications

NOMINAL IMPEDANCE: 50 Ω

FREQUENCY RANGE: dc to 40.0 GHz

MAXIMUM DEVIATION OVER FREQUENCY:

Nominal ATTN (dB)	Deviation (dB)	
	dc-26.5 GHz	26.5-40 GHz
3, 6, 10	± 0.50	± 1.00
20, 30	± 0.80	± 1.50

MAXIMUM SWR:

Frequency (GHz)	SWR
dc - 26.5	1.25
26.5 - 40	1.45

POWER RATING: 2 watts **average** to 25 °C ambient temperature, derated linearly to 0.2 watt at 100 °C. 200 watts **peak** (5 μsec pulse width; 0.5 % duty cycle).

POWER COEFFICIENT: < 0.005 dB/dB/watts

TEMPERATURE COEFFICIENT: < 0.0004 dB/dB/°C

TEMPERATURE RANGE: -55 °C to +100 °C

CONNECTORS: SMK (2.92mm) connectors - mate nondestructively with SMA connectors per MIL-C-39012, 3.5mm and other 2.92mm connectors.

CONSTRUCTION: Passivated stainless steel body and connectors; gold plated beryllium copper contacts. Each unit is sealed using low outgassing sealant.

WEIGHT: 8 g (0.3 oz.) maximum

PHYSICAL DIMENSIONS:

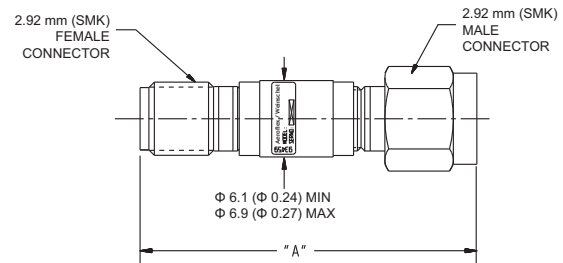

Model	DIM A
	+/-0.5mm (0.02inch)
32K	38.0 (1.50)
F32K	36.6 (1.44)
M32K	39.6 (1.56)

NOTE: All dimensions are given in mm (inches).

Screening

Thermal Shock: 10 cycles, -55 °C to +100 °C

Peak Power: 200 Watts, 5 μsec pulse width; 0.05% duty cycle for 3 minutes at each end. DC Attenuation is measured before and after peak power.

Monitored Thermal Cycle: Units are subjected to 15 thermal cycles between -55 °C to +100 °C. The PIN-to-PIN DC resistance is continuously monitored and stored.

Attenuation and SWR are tested as final electrical test.

MODEL NUMBER DESCRIPTION:

Example:

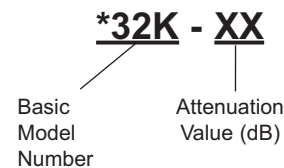

* Add Prefix M for double male and F for double female connectors.

EXPORT CONTROL:

This product is controlled for export under the International Traffic in Arms Regulations (ITAR). A license from the U.S. Department of State is required prior to the export of this product from the United States.

EXPORT WARNING:

Aeroflex's military and space products are controlled for export under the International Traffic in Arms Regulations (ITAR) and may not be sold or proposed or offered for sale to certain countries. (See ITAR 126.1 for complete information.)

Fixed Coaxial Attenuators



Model 41 Medium Power, SMA Connectors Bi-directional Design

dc to 18.0 GHz
10 Watts



Features

- /// Compact Construction - Lowest size/power ratio.
- /// Quality Connectors with special high temperature support beads.
- /// Designed to meet environmental requirements of MIL-DTL-3933.

Specifications

NOMINAL IMPEDANCE: 50 Ω

FREQUENCY RANGE: dc to 18.0 GHz

MAXIMUM DEVIATION OVER FREQUENCY:

Nominal ATTN (dB)	Deviation (dB)
1, 2	± 0.50
3, 6	± 0.30
10	± 0.50
20	± 0.70
30	± 1.00

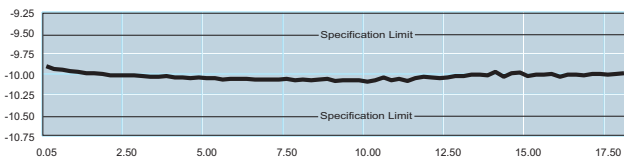

Typical Attenuation Accuracy

MAXIMUM SWR:

Frequency (GHz)	SWR
dc - 8	1.20
8 - 12.4	1.30
12.4 - 18	1.35

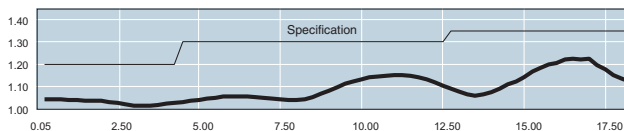

Typical SWR of a 41-10

POWER RATING (mounted horizontally): 10 watts average (bi-directional) to 25°C ambient temperature, derated linearly to 1 Watt @ 125°C. 1 kilowatt peak (5 μsec pulse width; 0.5% duty cycle).

POWER COEFFICIENT: <0.0015 dB/dB/watt

TEMPERATURE COEFFICIENT: <0.0004 dB/dB/°C

TEMPERATURE RANGE: -55 °C to 125 °C

TEST DATA: Swept data plots of attenuation and SWR from 50 MHz to 18 GHz supplied.

CONNECTORS: SMA (Male/Female) connectors per MIL-STD-348 interface dimensions - mate nondestructively with MIL-C-39012 connectors.

Connector Options	Type/Description
1	SMA, Female
2	SMA, Male

CONSTRUCTION: Black, finned aluminum body, gold plated beryllium copper contacts.

WEIGHT: 28 g (1 oz.) maximum

PHYSICAL DIMENSIONS:

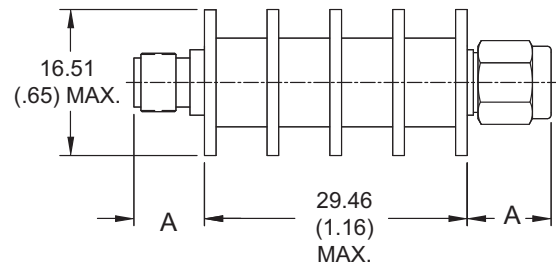

Connector	DIM A
SMA Male	11.18 (0.44)
SMA Female	9.4 (0.37)

NOTE: All dimensions are given in mm (inches) and are maximum, unless otherwise specified.

MODEL NUMBER DESCRIPTION:

Example:

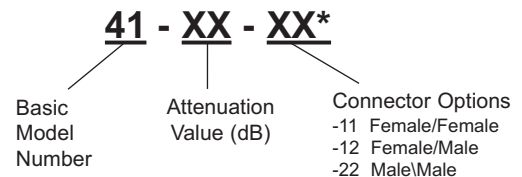

* Unit is bi-directional and full power may be applied to either connector.

Model 37 Medium Power, Type N Connectors Bi-directional Design!

dc to 8.5 GHz
10 Watts

 **RoHS**



Features

- /// Optimized for Wireless OEM & Test Applications.
- /// Precision injection molded connector dielectric.
- /// Designed to meet environmental requirements of MIL-DTL-3933.

Specifications

NOMINAL IMPEDANCE: 50 Ω

FREQUENCY RANGE: dc to 8.5 GHz

MAXIMUM DEVIATION OVER FREQUENCY:

Nominal ATTN (dB)	Deviation (dB)	
	dc-4 GHz	4 - 8.5 GHz
3, 6, 10, 20	± 0.30	± 0.50
30	± 0.50	± 0.80

MAXIMUM SWR:

Frequency (GHz)	SWR
dc - 4	1.15
4 - 8.5	1.25

POWER RATING (mounted horizontally): 10 watts **average (bi-directional)** to 25°C ambient temperature, derated linearly to 1 watts @ 125°C. Note: 3 dB model can handle 20 Watts **average (bi-directional)**. 1 kilowatt **peak** (5 μsec pulse width; 0.5% duty cycle).

POWER COEFFICIENT: <0.001 dB/dB/watt

TEMPERATURE COEFFICIENT: <0.0004 dB/dB/°C

TEMPERATURE RANGE: -55 °C to 125 °C

TEST DATA: Swept data plots of attenuation and SWR from 50 MHz to 8.5 GHz supplied.

CONNECTORS: Type N connectors per MIL-STD-348 interface dimensions - mate nondestructively with MIL-C-39012 connectors.

Connector Options	Type/Description
3	Type N, Female
4	Type N, Male

CONSTRUCTION: Black, finned aluminum body, gold plated beryllium copper contacts.

WEIGHT: 110 g (4 oz.) maximum

PHYSICAL DIMENSIONS:

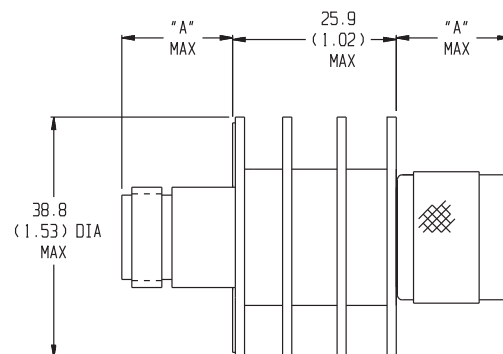

Connector	DIM A
N Male	24.1 (0.95)
N Female	19.1 (0.75)

NOTE: All dimensions are given in mm (inches) and are maximum, unless otherwise specified.

MODEL NUMBER DESCRIPTION:

Example:

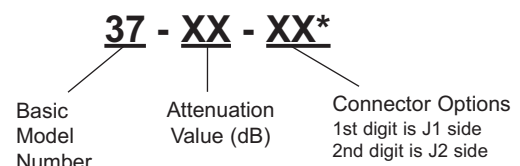

*Unit is bi-directional and full power may be applied to either J1 or J2.

Fixed Coaxial Attenuators



Model 23 Medium Power, Type N Connectors Bi-directional Design!

dc to 18.0 GHz
10 Watts



Features

- /// Precision injection molded connector dielectric.
- /// Designed to meet environmental requirements of MIL-DTL-3933.

Specifications

NOMINAL IMPEDANCE: 50 Ω

FREQUENCY RANGE: dc to 18.0 GHz

MAXIMUM DEVIATION OVER FREQUENCY:

Nominal ATTN (dB)	Deviation (dB)
1, 2	± 0.50
3, 6	± 0.30
10, 20	± 0.50
30, 40	± 1.00
50	± 1.25
60	± 1.50

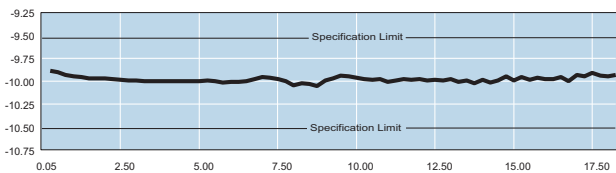

Typical Attenuation Accuracy of a 23-10-34

MAXIMUM SWR:

Frequency (GHz)	SWR
dc - 4	1.15
4 - 8	1.20
8 - 12.4	1.25
12.4 - 18	1.35

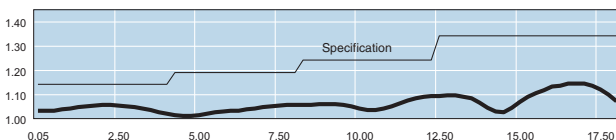

Typical SWR of a 23-10-34

POWER RATING (mounted horizontally): 10 watts average (bi-directional) to 25°C ambient temperature, derated linearly to 1 watts @ 125°C. 1 kilowatt peak (5 μsec pulse width; 0.5% duty cycle).

POWER COEFFICIENT: <0.001 dB/dB/watt

TEMPERATURE COEFFICIENT: <0.0004 dB/dB/°C

TEMPERATURE RANGE: -55°C to 125°C

TEST DATA: Swept data plots of attenuation and SWR from 50 MHz to 18 GHz supplied.

CONNECTORS: Type N connectors per MIL-STD-348 interface dimensions - mate nondestructively with MIL-C-39012 connectors.

Connector Options	Type/Description
3	Type N, Female
4	Type N, Male

CONSTRUCTION: Black, finned aluminum body, gold plated beryllium copper contacts.

WEIGHT: 110 g (4 oz.) maximum

PHYSICAL DIMENSIONS:

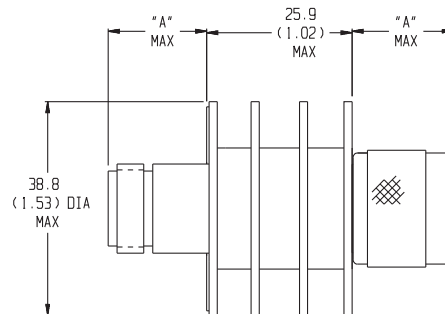

Connector	DIM A
N Male	24.1 (0.95)
N Female	19.1 (0.75)

NOTE: All dimensions are given in mm (inches) and are maximum, unless otherwise specified.

MODEL NUMBER DESCRIPTION:

Example:

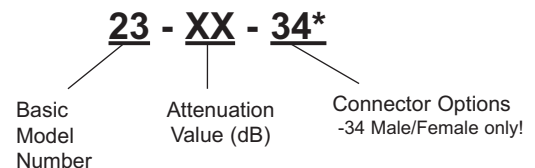

* Unit is bi-directional and full power may be applied to either J1 or J2.

Model 279 Medium Power, SMK Connectors

dc to 40.0 GHz
10 Watts



Features

- /// Compact Construction - Lowest size/power ratio.
- /// Precision injection molded connectors.
- /// Designed to meet environmental requirements of MIL-DTL-3933.

Specifications

NOMINAL IMPEDANCE: 50 Ω

FREQUENCY RANGE: dc to 40.0 GHz

MAXIMUM DEVIATION OVER FREQUENCY:

Nominal ATTN (dB)	Deviation (dB)
6, 10, 20, 30	± 1.5

MAXIMUM SWR:

Frequency (GHz)	SWR
dc - 18	1.20
18 - 40	1.35

POWER RATING (mounted horizontally): 10 watts **average (unidirectional)** to 25°C ambient temperature, derated linearly to 2 Watts @ 125°C. 200 watts **peak** (5 μsec pulse width; 5% duty cycle). Maximum power into output port is 5 Watts.

POWER COEFFICIENT: <0.002 dB/dB/watt

TEMPERATURE COEFFICIENT: <0.0004 dB/dB/°C

TEMPERATURE RANGE: -55 °C to 125 °C

TEST DATA: Swept data plots of attenuation and SWR from 50 MHz to 40 GHz.

CONNECTORS: SMK (2.92mm) Male/Female connectors - mate nondestructively with SMA per MIL-C-39012, 3.5mm and other 2.92mm connectors.

Connector Options	Type/Description
1	SMK (2.92mm), Female
2	SMK (2.92mm), Male

CONSTRUCTION: Black, finned aluminum body, gold plated beryllium copper contacts.

WEIGHT: 200 g (8.0 oz.) maximum

PHYSICAL DIMENSIONS:

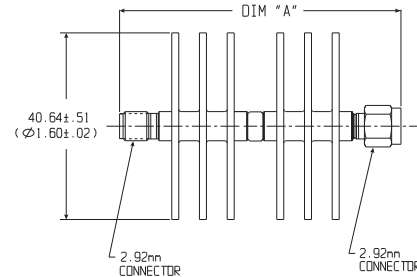

Dash No.	Connector Type	DIM A
11	SMK Female/Female	
12	SMK Female/Male	
21	SMK Male/Female	
22	SMK Male/Male	

NOTE: All dimensions are given in mm (inches) and are nominal, unless otherwise specified.

MODEL NUMBER DESCRIPTION:

Example:

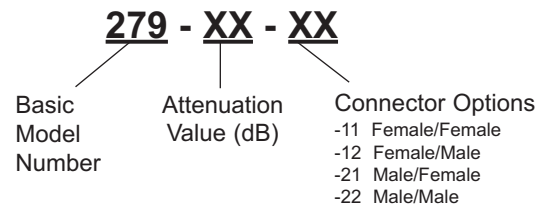

Model 89 Medium Power, SMK Connectors

dc to 40.0 GHz
20 Watts



Features

- /// Compact Construction - Lowest size/power ratio.
- /// Precision injection molded connectors.
- /// Designed to meet environmental requirements of MIL-DTL-3933.

Specifications

NOMINAL IMPEDANCE: 50 Ω

FREQUENCY RANGE: dc to 40.0 GHz

MAXIMUM DEVIATION OVER FREQUENCY:

Nominal ATTN (dB)	Deviation (dB)
10, 20, 30	± 1.5

MAXIMUM SWR:

Frequency (GHz)	SWR
dc - 18	1.25
18 - 40	1.40

POWER RATING (mounted horizontally): 20 watts **average (unidirectional)** to 25°C ambient temperature, derated linearly to 2 Watts @ 125°C. 200 watts **peak** (5 μsec pulse width; 5% duty cycle). Maximum power into output port is 5 Watts.

POWER COEFFICIENT: <0.002 dB/dB/watt

TEMPERATURE COEFFICIENT: <0.0004 dB/dB/°C

TEMPERATURE RANGE: -55 °C to 125 °C

TEST DATA: Swept data plots of attenuation and SWR from 50 MHz to 40 GHz.

CONNECTORS: SMK (2.92mm) Male/Female connectors - mate nondestructively with SMA per MIL-C-39012, 3.5mm and other 2.92mm connectors.

Connector Options	Type/Description
1	2.92mm, Female
2	2.92mm, Male

CONSTRUCTION: Black, finned aluminum body, gold plated beryllium copper contacts.

WEIGHT: 200 g (8.0 oz.) maximum

PHYSICAL DIMENSIONS:

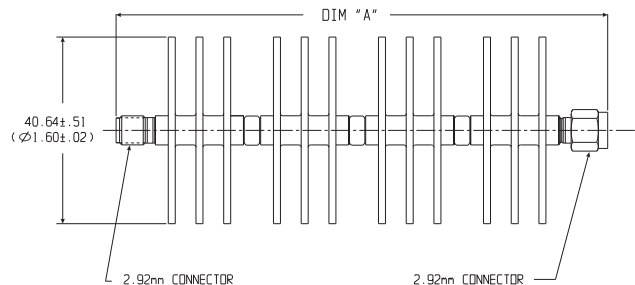

Dash No.	Connector Type	DIM A
11	2.92mm Female/Female	106.2 (4.18)
12	2.92mm Female/Male	109.2 (4.30)
21	2.92mm Male/Female	109.2 (4.30)
22	2.92mm Male/Male	112.0 (4.40)

NOTE: All dimensions are given in mm (inches) and are nominal, unless otherwise specified.

MODEL NUMBER DESCRIPTION:

Example:

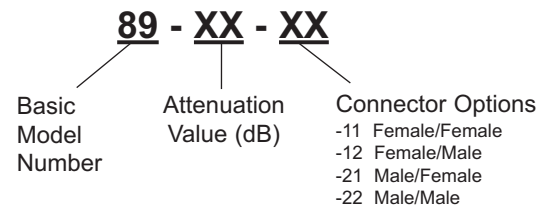

Fixed Coaxial Attenuators



Model 34

Medium Power, Type N or SMK Connectors
Bi-directional Design

dc to 4.0 GHz
25 Watts

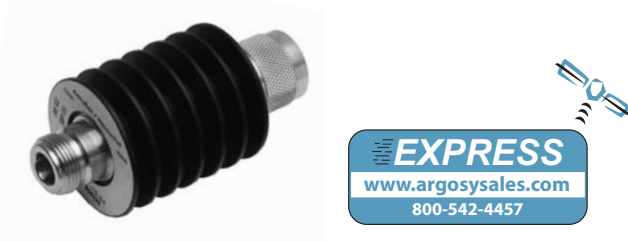

Features

- Optimized for Wireless OEM & Test Applications.
- Precision Connectors with high temperature support beads.
- Designed to meet environmental requirements of MIL-DTL-3933.

Specifications

NOMINAL IMPEDANCE: 50 Ω

FREQUENCY RANGE: dc to 4.0 GHz

MAXIMUM DEVIATION OVER FREQUENCY:

Nominal ATTN (dB)	Deviation (dB)	
	dc-2 GHz	2 - 4 GHz
3, 6, 10, 20, 30	± 0.60	± 1.00

MAXIMUM SWR*:

Frequency (GHz)	SWR
dc - 2	1.10
2 - 4	1.20

POWER RATING (mounted horizontally): 25 watts average (bi-directional) to 25°C ambient temperature, derated linearly to 2.5 watts @ 125°C. 5 kilowatt peak (5 μsec pulse width; 0.25% duty cycle).

POWER COEFFICIENT: <0.0006 dB/dB/watt

TEMPERATURE COEFFICIENT: <0.0004 dB/dB/°C

TEMPERATURE RANGE: -55 °C to 125 °C

TEST DATA: Swept data plots of attenuation and SWR from 50 MHz to 4 GHz is available at additional cost.

Type N connectors per MIL-STD-348 interface dimensions - mate nondestructively with MIL-C-39012 connectors. SMK (2.92mm) connectors - mate nondestructively with SMA per MIL-C-39012, 3.5mm, SMK, and other 2.92mm connectors.

Options	Description	Options	Description
1	SMK Female	3	Type N, Female
2	SMK Male	4	Type N, Male

CONSTRUCTION: Black, finned aluminum body, gold plated beryllium copper contacts.

WEIGHT: 170 g (6 oz.) maximum

PHYSICAL DIMENSIONS:

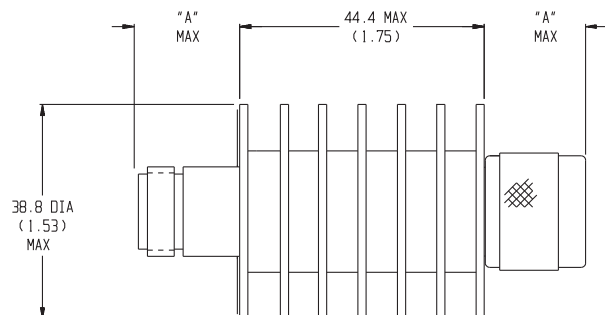

Connector	DIM A	Connector	DIM A
N Male	22.9 (0.90)	2.92mm Male	14.0 (0.55)
N Female	15.0 (0.59)	2.92mm Female	12.7 (0.50)

NOTE: All dimensions are given in mm (inches) and are maximum, unless otherwise specified..

MODEL NUMBER DESCRIPTION:

Example:

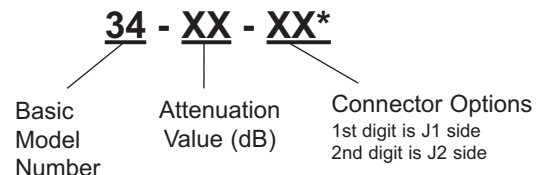

*Unit is bi-directional and full power may be applied to either J1 or J2.

Model 77 Medium Power, 7/16 Connectors

dc to 6.0 GHz
25 Watts



Features

- /// Optimized for Wireless OEM & Test Applications.
- /// Low Intermodulation Design.
- /// Designed to meet environmental requirements of MIL-A-3933.

Specifications

NOMINAL IMPEDANCE: 50 Ω

FREQUENCY RANGE: dc to 6.0 GHz

MAXIMUM DEVIATION OVER FREQUENCY:

Nominal ATTN (dB)	Deviation (dB)
10, 20	± 0.70
30	± 1.20

MAXIMUM SWR:

Frequency (GHz)	SWR
dc - 3	1.20
3 - 6	1.30

3rd ORDER INTERMODULATION (77-XX-XX-LIM Only): Reflected Levels (IM3), -100 dBc and Through Levels (IM3), -110 dBc with two input signals @ 869 MHz and 891 MHz with average carrier power levels of +41 dBm each.

POWER RATING (mounted horizontally): 25 watts **average (unidirectional)** to 25°C ambient temperature, derated linearly to 2.5 watts @ 125°C. Maximum power rating into output is 10 watts **average**. 5 kilowatt **peak** (5 μsec pulse width; 0.25% duty cycle).

POWER COEFFICIENT: <0.002 dB/dB/watt

TEMPERATURE COEFFICIENT: <0.0004 dB/dB/°C

TEMPERATURE RANGE: -55 °C to 125 °C

TEST DATA: Swept data plots of SWR from 50 MHz to 6 GHz supplied.

CONNECTORS: 7/16 connector that conforms to DIN 47223, IEC 169-4, VG 95250, CECC 22 190.

Connector Options	Type/Description
1	7/16 Female
2	7/16 Male

CONSTRUCTION: Black, finned aluminum body, silver plated brass connectors

WEIGHT: 280 g (10 oz.) maximum

PHYSICAL DIMENSIONS:

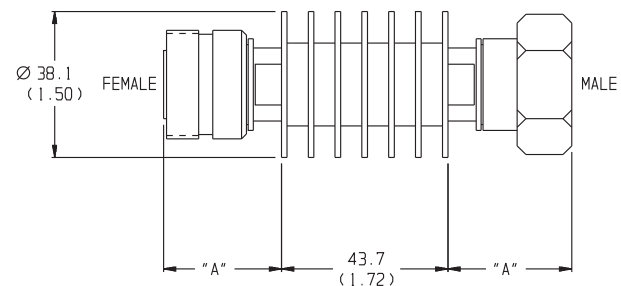

Connector	DIM A
7/16 Male	32.3 (1.27)
7/16 Female	30.7 (1.21)

NOTE: All dimensions are given in mm (inches) and tolerances are $XX \pm 0.8$ (0.03) unless otherwise specified.

MODEL NUMBER DESCRIPTION:

Example:

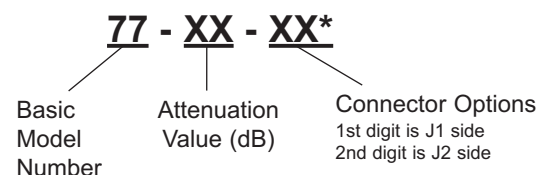

*Unit is bi-directional & full power may be applied to either J1 or J2.

Fixed Coaxial Attenuators



Model 33 Medium Power, N or SMK Connectors Bi-directional Design!

dc to 8.5 GHz
25 Watts
 RoHS



Features

- Quality Connectors with special high temperature support beads.
- Designed to meet environmental requirements of MIL-DTL-3933.
- Low Intermodulation option available.
- Mode free operation to 10 GHz.

Specifications

NOMINAL IMPEDANCE: 50 Ω

FREQUENCY RANGE: dc to 8.5 GHz

MAXIMUM DEVIATION OVER FREQUENCY (dB):

Nominal ATTN (dB)	33		33-LIM	
	dc-4 GHz	4 - 8.5 GHz	dc-4 GHz	4 - 8.5 GHz
3, 6	± 0.30	± 0.60	---	---
10, 20	± 0.30	± 0.60	± 0.40	± 0.70
30	± 0.60	± 1.00	± 0.70	± 1.20

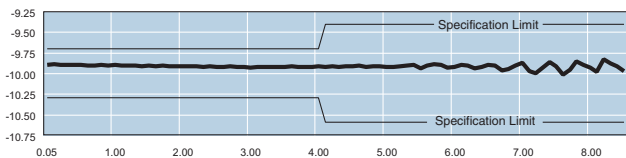

Typical Attenuation Accuracy of a 33-10-34

MAXIMUM SWR:

Frequency (GHz)	SWR
dc - 4	1.20
4 - 8.5	1.30

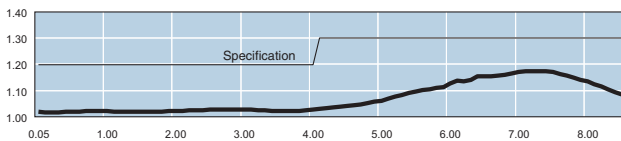

Typical SWR of a 33-10-34

3rd ORDER INTERMODULATION (33-XX-XX-LIM Only): Reflected Levels (IM3), -100 dBc and Through Levels (IM3), -110 dBc with two input signals @ 869 MHz and 891 MHz with average carrier power levels of +41 dBm each.

POWER RATING (mounted horizontally): 25 watts average (bi-directional) to 25°C ambient temperature, derated linearly to 2.5 watts @ 125°C. 5 kilowatt peak (5 μsec pulse width; 0.25% duty cycle).

POWER COEFFICIENT: <0.0006 dB/dB/watt

TEMPERATURE COEFFICIENT: <0.0004 dB/dB/°C

TEMPERATURE RANGE: -55 °C to 125 °C

TEST DATA: Swept data plots of attenuation and SWR from 50 MHz to 8.5 GHz.

CONNECTORS: Type N connectors per MIL-STD-348 interface dimensions - mate nondestructively with MIL-C-39012 connectors. SMK (2.92mm) connectors - mate nondestructively with SMA per MIL-C-39012, 3.5mm, SMK, and other 2.92mm. Female 2.92mm connector NOT RoHS compliant.

Options	Description	Options	Description
1	SMK Female	3	Type N, Female
2	SMK Male	4	Type N, Male

CONSTRUCTION: Black, finned aluminum body, gold plated beryllium copper contacts.

WEIGHT: 170 g (6 oz.) maximum

PHYSICAL DIMENSIONS:

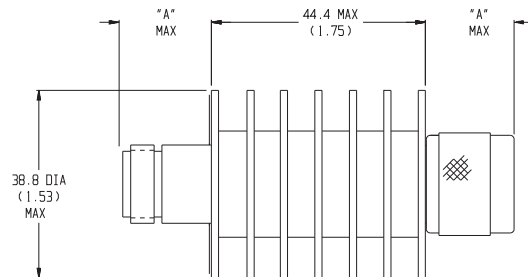

Connector	DIM A	Connector	DIM A
N Male	22.9 (0.90)	2.92mm Male	14.0 (0.55)
N Female	15.0 (0.59)	2.92mm Female	12.7 (0.50)

NOTE: All dimensions are given in mm (inches) and are maximum, unless otherwise specified.

MODEL NUMBER DESCRIPTION:

Example:

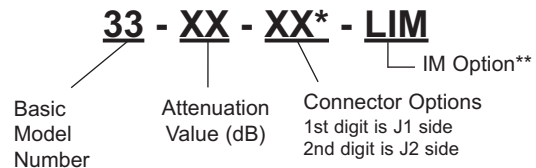

*Unit is bi-directional & full power may be applied to either J1 or J2.

**Add -LIM to entire model number for Low Intermodulation option.

Available in only 10, 20, 30 dB and is not available through Express.

Model 46 Medium Power, N or 3.5mm Connectors Bi-directional Design!

dc to 18.0 GHz
25 Watts



Features

- Designed to meet environmental requirements of MIL-DTL-3933.
- Rugged injection molded connectors.
- Low Intermodulation option available.

Specifications

NOMINAL IMPEDANCE: 50 Ω

FREQUENCY RANGE: dc to 18.0 GHz

MAXIMUM DEVIATION OVER FREQUENCY:			
Nominal ATTN (dB)	46	46 LIM	
		dc - 8 GHz	8- 18 GHz
1, 2	± 0.50	---	---
3, 6, 10, 20, 30, 40	± 1.00	± 1.00	+2.0/-1.0

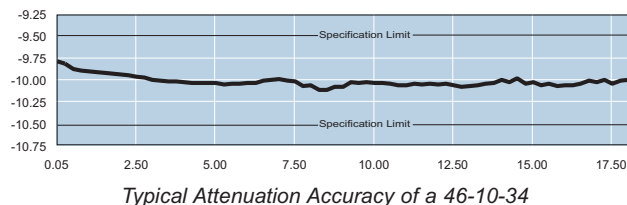

MAXIMUM SWR:	
Frequency (GHz)	SWR
dc - 8	1.15
8 - 12.4	1.20
12.4 - 18	1.30

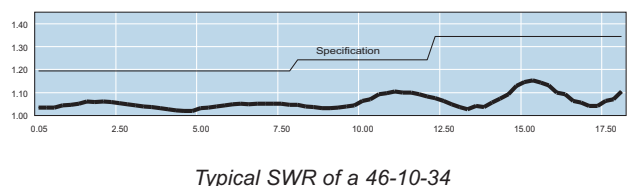

3rd ORDER INTERMODULATION (46-XX-XX-LIM ONLY): Reflected Levels (IM3), -100 dBc and Through Levels (IM3), -110 dBc with two input signals @ 869 MHz and 891 MHz with average carrier power levels of +41 dBm each. Option only available 10, 20, 30, 40 dB.

POWER RATING (mounted horizontally): 25 watts average (bi-directional) to 25°C ambient temperature, derated linearly to 2.5 watts @ 125°C. 1 kilowatt peak (5 μsec pulse width; 1.25% duty cycle).

POWER COEFFICIENT: <0.0006 dB/dB/watt

TEMPERATURE COEFFICIENT: <0.0004 dB/dB/°C

TEMPERATURE RANGE: -55°C to 125°C

TEST DATA: Swept data plots of attenuation and SWR from 50 MHz to 18 GHz supplied.

CONNECTORS: Type N connectors per MIL-STD-348 interface dimensions - mate nondestructively with MIL-C-39012 connectors.

3.5mm Connectors - mate nondestructively with SMA per MIL-C-39012, 2.92mm and other 3.5mm connectors.

Options	Description	Options	Description
1	3.5mm Female	3	Type N Female
2	3.5mm Male	4	Type N Male

CONSTRUCTION: Black, finned aluminum body, stainless steel connectors with gold plated beryllium copper contacts.

WEIGHT: 110 g (4 oz.) maximum

PHYSICAL DIMENSIONS:

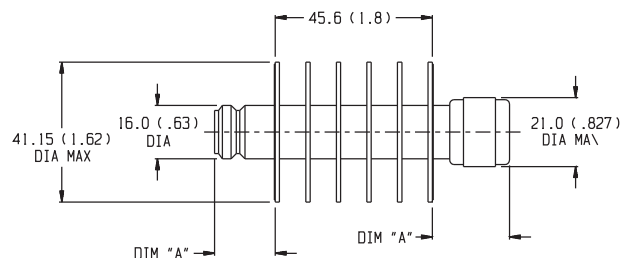

Connector	DIM A	Connector	DIM A
N Male	24.1 (0.95)	3.5mm Female	14.0 (0.55)
N Female	19.0 (0.75)	3.5mm Male	13.2 (0.52)

NOTE: All dimensions are given in mm (inches) and are maximum, unless otherwise specified.

MODEL NUMBER DESCRIPTION:

Example:

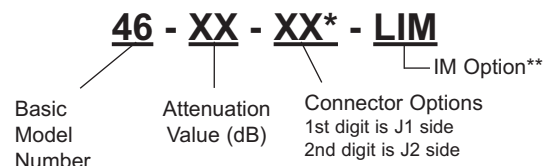

* Unit is bi-directional & full power may be applied to either J1 or J2.

** Add -LIM for Low Intermodulation option. Option only available in 10, 20, 30 and 40 dB and is not available through Express.

Fixed Coaxial Attenuators



Model 74 Medium Power, 3.5mm Connectors

dc to 28.0 GHz
25 Watts



Features

- /// Compact Construction - Lowest size/power ratio.
- /// Precision injection molded connectors.
- /// Designed to meet environmental requirements of MIL-DTL-3933.
- /// Low SWR Design.

Specifications

NOMINAL IMPEDANCE: 50 Ω

FREQUENCY RANGE: dc to 28 GHz

MAXIMUM DEVIATION OVER FREQUENCY:

Nominal ATTN (dB)	Deviation (dB)
3	± 0.70
6, 10	± 1.00
20, 30	± 1.50

MAXIMUM SWR:

Frequency (GHz)	SWR
dc - 18	1.30
18 - 28	1.35

POWER RATING: 25 watts **average (unidirectional)** to 25°C ambient temperature, derated linearly to 2.5 Watt @ 125°C. 500 watts **peak** (5 μsec pulse width; 2.5% duty cycle). Maximum power rating into output is 10% of the average power rating.

POWER COEFFICIENT: <0.0006 dB/dB/watt

TEMPERATURE COEFFICIENT: <0.0004 dB/dB/°C

TEMPERATURE RANGE: -55°C to 125°C

TEST DATA: Swept data plots of attenuation and SWR from 50 MHz to 28 GHz. .

CONNECTORS: 3.5mm (Male/Female) connectors - mate nondestructively with SMA per MIL-C-39012, 2.92mm and other 3.5mm connectors.

Connector Options	Type/Description
1	3.5mm, Female
2	3.5mm, Male

CONSTRUCTION: Black, finned aluminum body, gold plated beryllium copper contacts.

WEIGHT: 100 g (3.5 oz.) maximum

PHYSICAL DIMENSIONS:

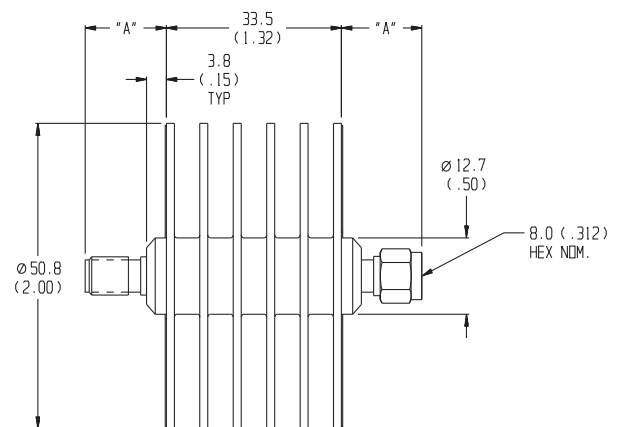

Connector	DIM A
3.5mm Male	16.0 (0.63)
3.5mm Female	15.0 (0.59)

NOTE: All dimensions are given in mm (inches) and are maximum, unless otherwise specified.

MODEL NUMBER DESCRIPTION:

Example:

74 - XX - XX

Basic Model Number

Attenuation Value (dB)

Connector Options
1st digit is input side
2nd digit is output side

Model 78 High Power, 7/16 Connectors Bi-Directional Design!

dc to 6.0 GHz
50 Watts



Features

- /// Optimized for Wireless OEM & Test Applications.
- /// Low Intermodulation Design.
- /// Designed to meet environmental requirements of MIL-A-3933.

Specifications

NOMINAL IMPEDANCE: 50 Ω

FREQUENCY RANGE: dc to 6.0 GHz

MAXIMUM DEVIATION OVER FREQUENCY:

Nominal ATTN (dB)	Deviation (dB)
10, 20	± 1.00
30	± 1.25

MAXIMUM SWR:

Frequency (GHz)	SWR
dc - 3	1.20
3 - 5	1.30

3rd ORDER INTERMODULATION: Reflected Levels (IM3), -100 dBc and Through Levels (IM3), -110 dBc with two input signals @ 869 MHz and 891 MHz with average carrier power levels of +43 dBm each.

POWER RATING (mounted horizontally): 50 watts average (bi-directional) to 25°C ambient temperature, derated linearly to 10 watts @ 125°C. 5 kilowatt peak (5 μsec pulse width; 0.5 % duty cycle).

POWER COEFFICIENT: <0.00015 dB/dB/watt

TEMPERATURE COEFFICIENT: <0.0004 dB/dB/°C

TEMPERATURE RANGE: -55 °C to 125 °C

TEST DATA: Swept data plots of SWR from 50 MHz to 6 GHz supplied.

CONNECTORS: 7/16 connector that conforms to DIN 47223, IEC 169-4, VG 95250, CECC 22 190.

Connector Options	Type/Description
1	7/16 Female
2	7/16 Male

CONSTRUCTION: Black, finned aluminum body, silver plated brass connectors.

WEIGHT: 392 g (14 oz.) maximum

PHYSICAL DIMENSIONS:

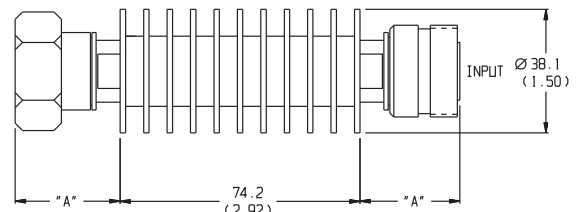

Connector	DIM A
7/16 Male	32.3 (1.27)
7/16 Female	30.7 (1.21)

NOTE: All dimensions are given in mm (inches) and tolerances are X.X±0.8 (0.03) unless otherwise specified.

MODEL NUMBER DESCRIPTION:

Example:

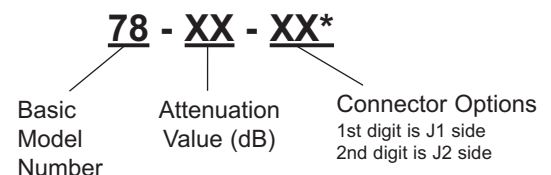

*Unit is bi-directional & full power may be applied to either J1 or J2.

Fixed Coaxial Attenuators



Model 24 Medium Power, N & SMK Connectors Bi-Directional Design!

dc to 8.5 GHz
50 Watts



Features

- Designed to meet environmental requirements of MIL-DTL-3933.
- Low Intermodulation option available.
- Mode free operation to 10 GHz.

Specifications

NOMINAL IMPEDANCE: 50 Ω
FREQUENCY RANGE: dc to 8.5 GHz

MAXIMUM DEVIATION OVER FREQUENCY (dB):

Nominal ATTN (dB)	24		24-LIM	
	dc-4 GHz	4 - 8.5 GHz	dc-4 GHz	4 - 8.5 GHz
3, 6, 10, 20	± 0.40	± 0.75	± 0.40	± 0.75
30, 40	± 0.60	± 0.70	± 0.60	± 0.70

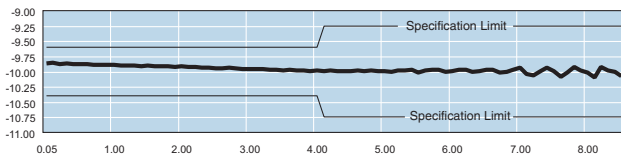

Typical Attenuation Accuracy of a 24-10-34

MAXIMUM SWR:

Frequency (GHz)	SWR
dc - 4	1.20
4 - 8.5	1.30

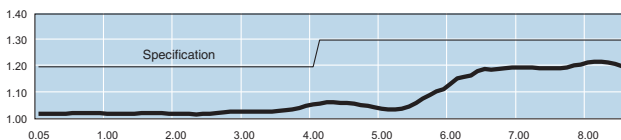

Typical SWR of a 24-10-34

3rd ORDER INTERMODULATION (24-XX-XX-LIM only!): Reflected Levels (IM3), -100 & Through Levels (IM3), -110 dBc with two input signals @ 869 MHz and 891 MHz with average carrier power levels of +43 dBm each.

POWER RATING (mounted horizontally): 50 watts average (bi-directional) to 25°C ambient temperature, derated linearly to 2.5 watts @ 125°C. 5 kilowatt peak (5 μsec pulse width; 0.5% duty cycle).

POWER COEFFICIENT: <0.0003 dB/dB/watt

TEMPERATURE COEFFICIENT: <0.0004 dB/dB/°C

TEMPERATURE RANGE: -55°C to 125°C

TEST DATA: Swept data plots of attenuation and SWR from 50 MHz to 8.5 GHz supplied.

CONNECTORS: Type N connectors per MIL-STD-348 interface dimensions - mate nondestructively with MIL-C-39012 connectors. SMK (2.92mm) connectors - mate nondestructively with SMA per MIL-C-39012, 3.5mm, SMK, and other 2.92mm.

Options	Descriptions	Options	Descriptions
1	SMK, Female	3	Type N, Female
2	SMK, Male	4	Type N, Male

CONSTRUCTION: Black, finned aluminum body, gold plated beryllium copper contacts.

WEIGHT: 171 g (6 oz.) maximum

PHYSICAL DIMENSIONS:

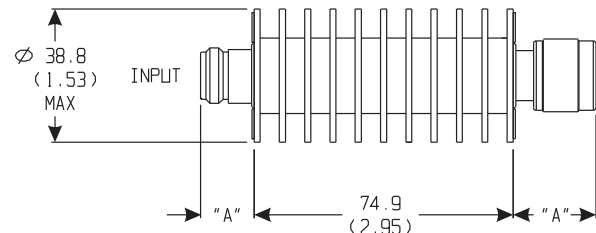

Connector	DIM A	Connector	DIM A
N Male	22.9 (0.90)	SMK Male	14.0 (0.55)
N Female	15.0 (0.59)	SMK Female	12.7 (0.50)

NOTE: All dimensions are given in mm (inches) and are maximum, unless otherwise specified.

MODEL NUMBER DESCRIPTION:

Example:

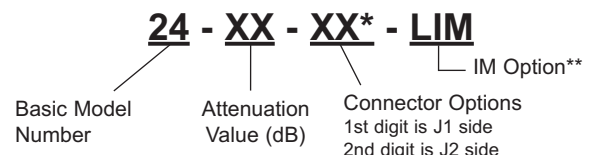

*Unit is bi-directional & full power may be applied to either J1 or J2.

**Add -LIM to entire model number for Low Intermodulation option. Option only available in 10, 20, 30, 40 dB and is not available through Express.

Model 90 Medium Power, N & 3.5mm Connectors Bi-directional Design

dc to 18.0 GHz
50 Watts



Features

- /// Precision injection molded connectors.
- /// Designed to meet environmental requirements of MIL-DTL-3933.
- /// Flat Response.
- /// Low Intermodulation option available.

Specifications

NOMINAL IMPEDANCE: 50 Ω

FREQUENCY RANGE: dc to 18.0 GHz

MAXIMUM DEVIATION OVER FREQUENCY:

Nominal ATTN (dB)	Deviation (dB)	
	90	90-LIM
3, 6	± 1.0	---
10, 20, 30	± 1.0	+2.0 / -1.0

MAXIMUM SWR:

Frequency (GHz)	SWR
dc - 8	1.15
8 - 12.4	1.20
12.4 - 18	1.30

3rd ORDER INTERMODULATION (90-XX-XX-LIM ONLY): Reflected Levels (IM3), -100 dBc and Through Levels (IM3), -110 dBc with two input signals @ 869 MHz and 891 MHz with average carrier power levels of +43 dBm each. Option only available 10, 20, 30 dB.

POWER RATING (mounted horizontally): 50 watts average (bi-directional) to 25°C ambient temperature, derated linearly to 5 Watts @ 125°C. 1 kW peak (5 μsec pulse width; 2.5% duty cycle).

POWER COEFFICIENT: <0.0003 dB/dB/watt

TEMPERATURE COEFFICIENT: <0.0004 dB/dB/°C

TEMPERATURE RANGE: -55 °C to 125 °C

TEST DATA: Swept data plots of attenuation and SWR from 50 MHz to 18 GHz. Frequency markers at 0.05, 2.0, 4.0, 8.0, 12.4, 18.0 GHz

CONNECTORS: Type N connectors per MIL-STD-348 interface dimensions - mate nondestructively with MIL-C-39012 connectors.

3.5mm Connectors - mate nondestructively with SMA per MIL-C-39012, 2.92mm and 3.5mm connectors.

Options	Description	Options	Description
1	3.5mm Female	3	Type N, Female
2	3.5mm Male	4	Type N, Male

CONSTRUCTION: Black, finned aluminum body, gold plated beryllium copper contacts.

WEIGHT: 120 g (4.2 oz.) maximum

PHYSICAL DIMENSIONS:

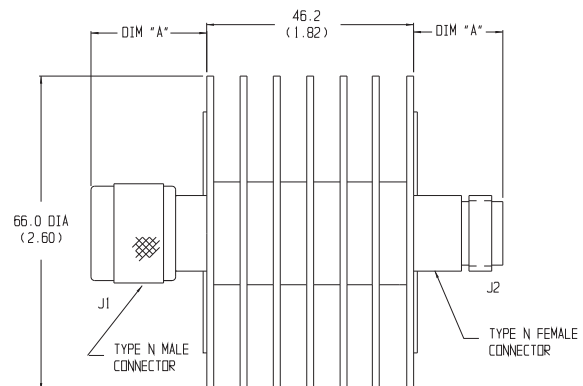

Connector	DIM A	Connector	DIM A
N Male	24.1 (0.95)	3.5mm Male	14.0 (0.55)
N Female	19.0 (0.75)	3.5mm Female	13.2 (0.52)

NOTE: All dimensions are given in mm (inches) and are maximum, unless otherwise specified.

MODEL NUMBER DESCRIPTION:

Example:

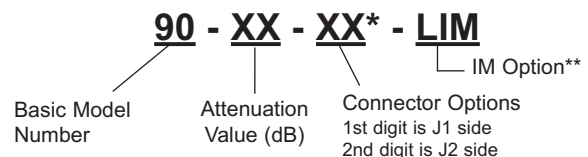

* Unit is bi-directional & full power may be applied to either J1 or J2.

**Add -LIM to entire model number for Low Intermodulation option. Option only available in 10, 20, 30 dB.

Fixed Coaxial Attenuators



Model 47 Medium Power, N or 3.5mm Connectors

dc to 18.0 GHz
50 Watts



Features

- Designed to meet environmental requirements of MIL-DTL-3933.
- Rugged injection molded connectors.

Specifications

NOMINAL IMPEDANCE: 50 Ω

FREQUENCY RANGE: dc to 18.0 GHz

MAXIMUM DEVIATION OVER FREQUENCY:

Nominal ATTN (dB)	Deviation (dB)
3, 6	± 0.75
10, 20	± 0.75
30, 40	± 1.00

MAXIMUM SWR:

Frequency (GHz)	3, 6 dB	10, 20, 30, 40 dB
dc - 8	1.25	1.20
8 -12.4	1.35	1.25
12.4 - 18	1.45	1.35

POWER RATING (mounted horizontally): 50 watts average (unidirectional) to 25°C ambient temperature, derated linearly to 5 watts @ 125°C. Note: 3 dB model can handle 100 Watts average (unidirectional). 1 kilowatt peak (5 μsec pulse width; 2.5% duty cycle). Maximum power rating into output port is 10 Watts average.

POWER COEFFICIENT: <0.0003 dB/dB/watt

TEMPERATURE COEFFICIENT: <0.0004 dB/dB/°C

TEMPERATURE RANGE: -55°C to 125°C

TEST DATA: Swept data plots of attenuation and SWR from 50 MHz to 18 GHz.

CONNECTORS: Type N connectors per MIL-STD-348 interface dimensions - mate nondestructively with MIL-C-39012 connectors.

3.5mm Connectors - mate nondestructively with SMA per MIL-C-39012, 2.92mm and other 3.5mm connectors.

Options	Description	Options	Description
1	3.5mm Female	3	Type N Female
2	3.5mm Male	4	Type N Male

CONSTRUCTION: Black, finned aluminum body, stainless steel connectors with gold plated beryllium copper contacts.

WEIGHT: 175 g (6 oz.) maximum

PHYSICAL DIMENSIONS:

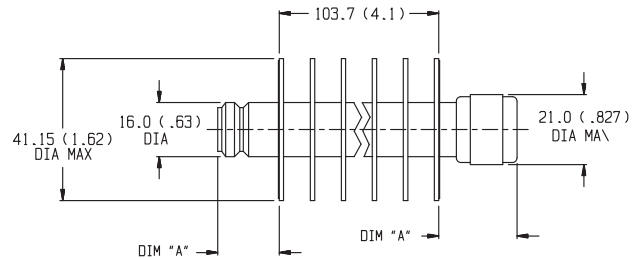

Connector	DIM A	Connector	DIM A
N Male	24.1 (0.95)	3.5mm Female	14.0 (0.55)
N Female	19.0 (0.75)	3.5mm Male	13.2 (0.52)

NOTE: All dimensions are given in mm (inches) and are maximum, unless otherwise specified.

MODEL NUMBER DESCRIPTION:

Example:

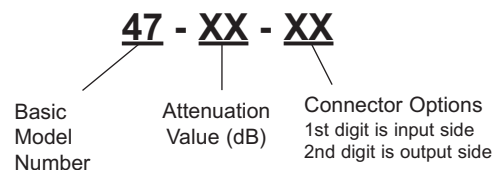

Model 68 High Power, N or SMK Connectors Convection Cooled

dc to 4.0 GHz
100 Watts



Features

- /// Precision Connectors with high temperature support beads.
- /// Designed to meet environmental requirements of MIL-DTL-3933.
- /// 10 Kilowatts peak, Convection Cooled
- /// Wireless Applications - Optimized for use in the communications bands.

Specifications

NOMINAL IMPEDANCE: 50 Ω
FREQUENCY RANGE: dc to 4.0 GHz

MAXIMUM DEVIATION OVER FREQUENCY:	
Nominal ATTN (dB)	Deviation (dB)
1, 2	± 1.00
3, 6, 10, 20, 30	± 1.25
40	± 2.00

MAXIMUM SWR:	
Frequency (GHz)	SWR
dc - 4	1.20

PHYSICAL DIMENSIONS:

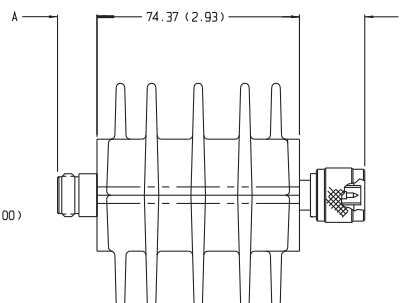
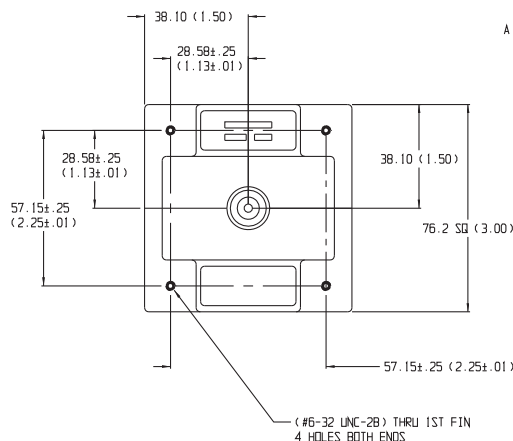

Connector	DIM A	Connector	DIM A
N Male	22.9 (0.90)	2.92mm Male	14.0 (0.55)
N Female	15.0 (0.59)	2.92mm Female	12.7 (0.50)

POWER RATING (mounted horizontally): 100 watts average (unidirectional) to 25°C ambient temperature, derated linearly to 10 watts @ 125°C. 10 kilowatts peak (5 μsec pulse width; 0.5% duty cycle). Maximum power rating into output port is 10% of the average power rating.

POWER COEFFICIENT: <0.00015 dB/dB/watt

TEMPERATURE COEFFICIENT: <0.0004 dB/dB/°C

TEMPERATURE RANGE: -55°C to 125°C

TEST DATA: Swept data plots of attenuation and SWR from 50 MHz to 4 GHz is available at additional cost.

CONNECTORS: Type N connectors per MIL-STD-348 interface dimensions - mate nondestructively with MIL-C-39012 connectors. SMK (2.92mm) connectors - mate nondestructively with SMA per MIL-C-39012, 3.5mm, SMK, and other 2.92mm connectors.

Options	Description	Options	Description
1	SMK, Female	3	Type N, Female
2	SMK, Male	4	Type N, Male

CONSTRUCTION: Aluminum alloy body, stainless steel connectors; gold plated beryllium copper contacts.

WEIGHT: 500 g (18 oz.) maximum

MODEL NUMBER DESCRIPTION:

Example:

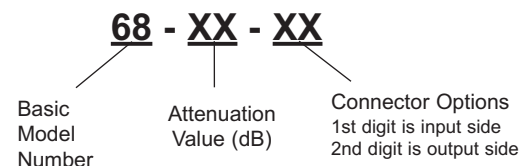

NOTE: All dimensions are given in mm (inches) and are maximum, unless otherwise specified.

Fixed Coaxial Attenuators



Model 73 High Power, N or SMK Connectors

dc to 8.5 GHz
100 Watts

RoHS



POWER RATING (mounted horizontally with fins vertical): 100 watts **average** (unidirectional) to 25°C ambient temperature, derated linearly to 10 watts @ 125°C. 5 kilowatt **peak** (5 μsec pulse width; 1.0% duty cycle). Maximum power rating into output port is 20 watts average.

POWER COEFFICIENT: <0.00015 dB/dB/watt

TEMPERATURE COEFFICIENT: <0.0004 dB/dB/°C

TEMPERATURE RANGE: -55°C to 125°C

TEST DATA: Swept data plots of SWR from 50 MHz to 8.5 GHz.

CONNECTORS: Type N connectors per MIL-STD-348 interface dimensions - mate nondestructively with MIL-C-39012 connectors. SMK (2.92mm) connectors - mate nondestructively with SMA per MIL-C-39012, 3.5mm, SMK, and other 2.92mm connectors.

Options	Description	Options	Description
1	SMK, Female	3	Type N, Female
2	SMK, Male	4	Type N, Male

CONSTRUCTION: Aluminum alloy body, stainless steel connectors; gold plated beryllium copper contacts.

WEIGHT: 1130 g (2 lbs, 8 oz.) maximum

Features

- /// **Compact Construction** - Lowest size/power ratio.
- /// **Quality connectors with special high temperature support beads.**
- /// **Designed to meet environmental requirements of MIL-DTL-3933.**

Specifications

NOMINAL IMPEDANCE: 50 Ω

FREQUENCY RANGE: dc to 8.5 GHz

MAXIMUM DEVIATION OVER FREQUENCY:

Nominal ATTN (dB)	Deviation (dB)
3, 6, 10, 20, 30	± 0.75
40	+1 / -0.50

MAXIMUM SWR:

Frequency (GHz)	SWR
dc - 4	1.25
4 - 8.5	1.35

PHYSICAL DIMENSIONS:

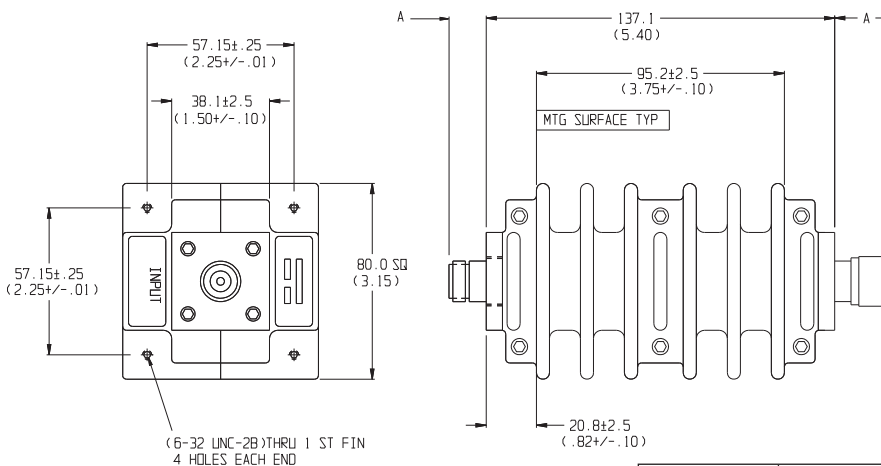

MODEL NUMBER DESCRIPTION:

Example:

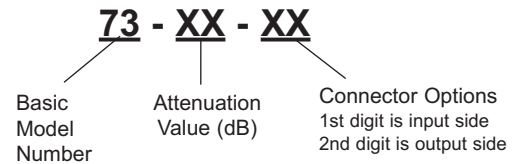

NOTE: All dimensions are given in mm (inches) and are maximum, unless otherwise specified.

Connector	DIM A	Connector	DIM A
N Male	22.9 (0.90)	2.92mm Male	14.0 (0.55)
N Female	15.0 (0.59)	2.92mm Female	12.7 (0.50)

Model 260 High Power, N or 3.5mm Connectors

dc to 18.0 GHz
100 Watts
NEW

RoHS



Features

- /// Designed to meet environmental requirements of MIL-DTL-3933.
- /// Low Intermodulation option available.
- /// Rugged injection molded connectors.

Specifications

NOMINAL IMPEDANCE: 50 Ω
FREQUENCY RANGE: dc to 18.0 GHz

MAXIMUM DEVIATION OVER FREQUENCY:

Nominal ATTN (dB)	260	260 LIM
6	± 0.75	---
10, 20	± 0.75	+2.0/-0.75
30	± 1.00	+2.0/-0.75

MAXIMUM SWR:

Frequency (GHz)	6 dB	10, 20, 30 dB
dc - 8	1.25	1.20
8 -12.4	1.35	1.25
12.4 - 18	1.45	1.35

3rd ORDER INTERMODULATION (260-XX-XX-LIM ONLY): Reflected Levels (IM3), -100 & Through Levels (IM3), -110 dBc with two input signals @ 869 MHz and 891 MHz with average carrier power levels of +43 dBm each. Option only available 10, 20, 30 dB.

POWER RATING (mounted horizontally): 100 watts average (unidirectional) to 25°C ambient temperature, derated linearly to 10 watts @ 125°C. 1 kilowatt peak (5 µsec pulse width; 5% duty cycle). Maximum power rating into output port is 20 Watts average.

POWER COEFFICIENT: <0.00015 dB/dB/watt

TEMPERATURE COEFFICIENT: <0.0004 dB/dB/°C

TEMPERATURE RANGE: -55°C to 125°C

TEST DATA: Swept data plots of attenuation and SWR from 50 MHz to 18 GHz.

CONNECTORS: Type N connectors per MIL-STD-348 interface dimensions - mate nondestructively with MIL-C-39012 connectors. 3.5mm connectors - mate nondestructively with SMA per MIL-C-39012, 3.5mm, SMK, and other 2.92mm connectors.

Options	Description	Options	Description
1	3.5mm Female	3	Type N Female
2	3.5mm Male	4	Type N Male

CONSTRUCTION: Black, finned aluminum body, stainless steel connectors with gold plated beryllium copper contacts.

WEIGHT: 340 g (12.0 oz.) maximum

PHYSICAL DIMENSIONS:

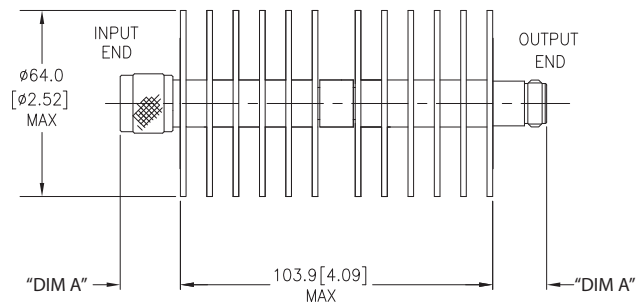

Connector	DIM A	Connector	DIM A
N Male	24.1 (0.95)	3.5mm Female	14.0 (0.55)
N Female	19.0 (0.75)	3.5mm Male	13.2 (0.52)

NOTE: All dimensions are given in mm (inches) and are maximum, unless otherwise specified.

MODEL NUMBER DESCRIPTION:

Example:

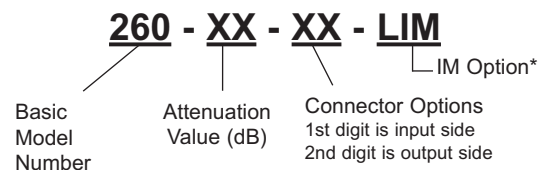

* Add -LIM for Low Intermodulation option. Option only available in 10, 20, and 30 dB.

Fixed Coaxial Attenuators



Model 48 High Power, N & 3.5mm Connectors

dc to 18.0 GHz
100 Watts



Features

- Designed to meet environmental requirements of MIL-DTL-3933.
- Rugged injection molded connectors.

Specifications

NOMINAL IMPEDANCE: 50 Ω

FREQUENCY RANGE: dc to 18.0 GHz

MAXIMUM DEVIATION OVER FREQUENCY:

Nominal ATTN (dB)	Deviation (dB)
6	± 2.00
10	± 2.00
20, 30, 40	± 1.00

MAXIMUM SWR:

Frequency (GHz)	6 dB	10 dB	20, 30, 40 dB
dc - 8	1.30	1.40	1.25
8 - 12.4	1.45	1.40	1.35
12.4 - 18	1.60	1.55	1.45

POWER RATING (mounted horizontally): 100 watts average (unidirectional) to 25°C ambient temperature, derated linearly to 10 watts @ 125°C. 1 kilowatt peak (5 μsec pulse width; 5% duty cycle). Maximum power rating into output port is 10 Watts average.

POWER COEFFICIENT: <0.00015 dB/dB/watt

TEMPERATURE COEFFICIENT: <0.0004 dB/dB/°C

TEMPERATURE RANGE: -55°C to 125°C

TEST DATA: Swept data plots of attenuation and SWR from 50 MHz to 18 GHz.

CONNECTORS: Type N connectors per MIL-STD-348 interface dimensions - mate nondestructively with MIL-C-39012 connectors.

3.5mm (Male/Female) connectors - mate nondestructively with SMA per MIL-C-39012, 2.92mm and other 3.5mm connectors.

Connector Options	Type/Description
1	3.5mm, Female
2	3.5mm, Male
3	Type N, Female
4	Type N, Male

CONSTRUCTION: Black, finned aluminum body, stainless steel connectors, gold plated beryllium copper contacts.

WEIGHT: 383 g (13.5 oz.) maximum

PHYSICAL DIMENSIONS:

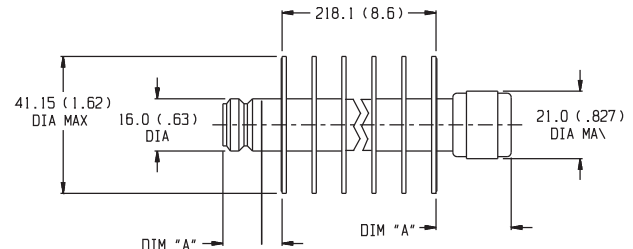

Connector	DIM A
3.5mm Female	13.2 (0.52)
3.5mm Male	14.0 (0.55)
N Male	24.1 (0.95)
N Female	19.0 (0.75)

NOTE: All dimensions are given in mm (inches) and are maximum, unless otherwise specified.

MODEL NUMBER DESCRIPTION:

Example:

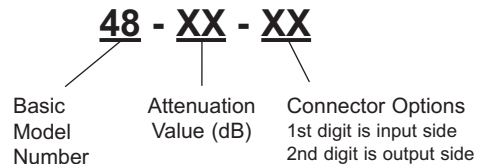

Model 40

Model 57

High Power, N or SMK Connectors

dc to 1.5 GHz

dc to 6.0 GHz

150 Watts

RoHS



Features

- /// Quality connectors with special high temperature support beads.
- /// Designed to meet environmental requirements of MIL-DTL-3933.

Specifications

NOMINAL IMPEDANCE: 50 Ω

FREQUENCY RANGE: Model 40: dc to 1.5 GHz
Model 57: dc to 6.0 GHz

MAXIMUM DEVIATION OVER FREQUENCY:			
Nominal ATTN (dB)	Deviation (dB)		
	40	57	57-LIM
3	± 0.50	± 1.25	---
6, 10	± 0.50	± 1.25	± 1.75
20, 30	± 0.50	± 1.50	± 2.00
40	± 0.50	± 2.00	± 2.00

MAXIMUM SWR:		
Frequency (GHz)	Input	Output
dc - 2 (1.5*)	1.10	1.10
2 - 6	1.15	1.20

* Model 40 only!

3rd ORDER INTERMODULATION (57-XX-XX-LIM ONLY): Reflected Levels (IM3), -100 & Through Levels (IM3), -110 dBc with two input signals @ 869 MHz and 891 MHz with average carrier power levels of +43 dBm each. Option only available 6, 10, 20, 30, 40 dB.

PHYSICAL DIMENSIONS:

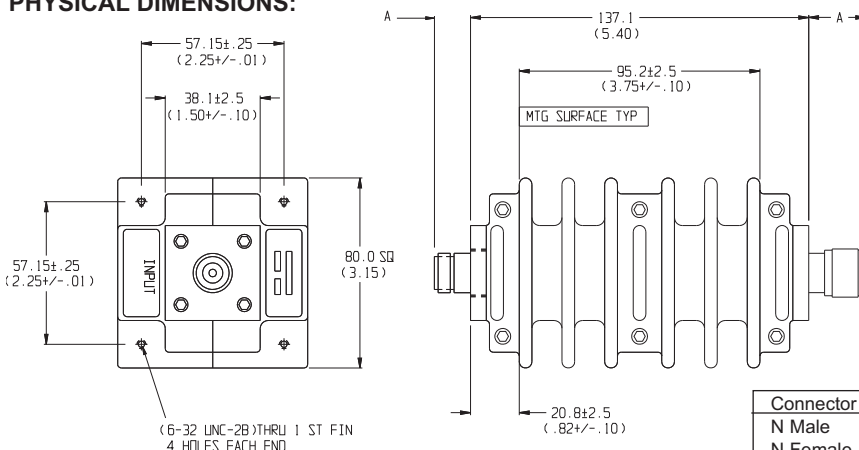

NOTE: All dimensions are given in mm (inches) and are maximum, unless otherwise specified.

Connector	DIM A	Connector	DIM A
N Male	22.9 (0.90)	2.92mm Male	14.0 (0.55)
N Female	15.0 (0.59)	2.92mm Female	12.7 (0.50)

POWER RATING (mounted horizontally with fins vertical): 150 watts **average** (unidirectional) to 25°C ambient temperature, derated linearly to 15 watts @ 125°C. 10 kilowatt **peak** (5 μsec pulse width; 0.75% duty cycle). Maximum power rating into output port is 20 watts average.

POWER COEFFICIENT: <0.0001 dB/dB/watt

TEMPERATURE COEFFICIENT: <0.0004 dB/dB/°C

TEMPERATURE RANGE: -55°C to 125°C

TEST DATA: Swept data plots of attenuation and SWR from 50 MHz to 1,5 / 6 GHz.

CONNECTORS: Type N connectors per MIL-STD-348 interface dimensions - mate nondestructively with MIL-C-39012 connectors. SMK (2.92mm) connectors - mate nondestructively with SMA per MIL-C-39012, 3.5mm, SMK, and other 2.92mm connectors.

Options	Description	Options	Description
1	SMK Female	3	Type N Female
2	SMK Male	4	Type N Male

CONSTRUCTION: Aluminum alloy body, stainless steel connectors; gold plated beryllium female copper contacts and stainless steel male contacts.

WEIGHT: 1,130 g (2 lbs, 8 oz.) maximum

MODEL NUMBER DESCRIPTION:

Example:

57 - XX - XX - LIM
IM Option*

Basic Model Number Attenuation Value (dB) Connector Options
1st digit is input side
2nd digit is output side

* Add -LIM for Low Intermodulation option. Option only available with Model 57 in 6, 10, 20, 30, 40 dB and is not available through Express.

Model 65 High Power, N or SMK Connectors Conduction/Convection Cooled

dc to 2.5 GHz
150 Watts



Features

- /// **Compact Construction** - Lowest size/power ratio.
- /// **Flexible Mounting Position** - The units may be mounted in horizontal (fins up) or vertical position.
- /// **Rugged Construction** - Quality connectors with special high temperature support beads.

Specifications

NOMINAL IMPEDANCE: 50 Ω

FREQUENCY RANGE: dc to 2.5 GHz

MAXIMUM DEVIATION OVER FREQUENCY:

Nominal ATTN (dB)	Deviation (dB)
3, 6, 10, 20, 30	± 1.00

MAXIMUM SWR:

Frequency (GHz)	SWR
dc - 2.5	1.20

PHYSICAL DIMENSIONS:

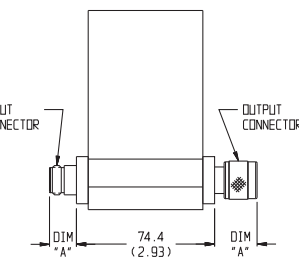
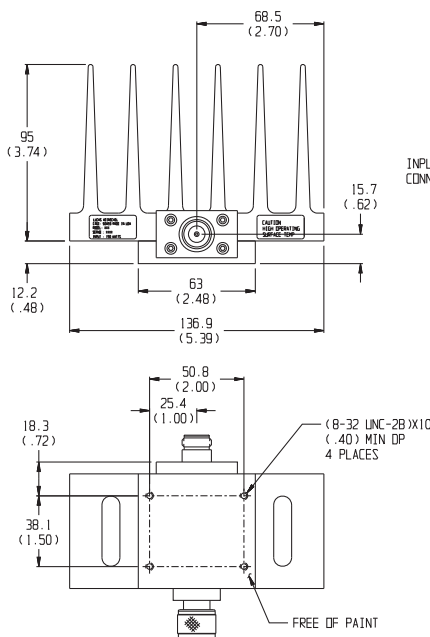

Connector	DIM A	Connector	DIM A
N Male	22.9 (0.90)	2.92mm Male	14.0 (0.55)
N Female	15.0 (0.59)	2.92mm Female	12.7 (0.50)

NOTE: All dimensions are given in mm (inches) and are maximum, unless otherwise specified.

POWER RATING 150 watts **average** (unidirectional), 10 kilowatts **peak** (5 μsec pulse width; 0.75 % duty cycle) with case temperature held within **100 °C maximum** with appropriate convection cooling and/or conductive heat sink. Maximum power rating into output port is 20 watts average.

POWER COEFFICIENT: <0.0001 dB/dB/watt

TEMPERATURE COEFFICIENT: <0.0004 dB/dB/°C

TEMPERATURE RANGE: -55°C to 100°C (case temp.)

TEST DATA: Swept data plots of attenuation and SWR from 50 MHz to 2.5 GHz.

CONNECTORS: Type N connectors per MIL-STD-348 interface dimensions - mate nondestructively with MIL-C-39012 connectors. SMK (2.92mm) connectors - mate nondestructively with SMA per MIL-C-39012, 3.5mm, SMK, and other 2.92mm connectors.

Options	Description	Options	Description
1	SMK Female	3	Type N Female
2	SMK Male	4	Type N Male

CONSTRUCTION: Aluminum alloy body, stainless steel connectors; gold plated beryllium copper contacts.

WEIGHT: 850 g (1 lbs., 14 oz.) maximum

MODEL NUMBER DESCRIPTION:

Example:

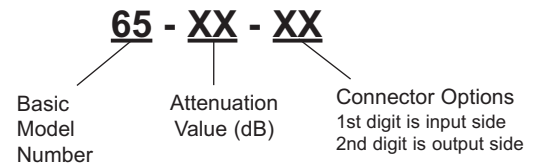

Model 79 High Power, 7/16 Connectors

dc to 6.0 GHz
150 Watts



Features

- /// Optimized for Wireless OEM & Test Applications.
- /// Low Intermodulation Design.
- /// Designed to meet environmental requirements of MIL-A-3933.

Specifications

NOMINAL IMPEDANCE: 50 Ω

FREQUENCY RANGE: dc to 5.0 GHz

MAXIMUM DEVIATION OVER FREQUENCY:

Nominal ATTN (dB)	Deviation (dB)
10, 20	± 0.90
30	± 1.25

MAXIMUM SWR:

Frequency (GHz)	SWR
dc - 3	1.20
3 - 6	1.35

3rd ORDER INTERMODULATION: Reflected Levels (IM3), -100 & Through Levels (IM3), -110 dBc with two input signals @ 869 MHz and 891 MHz with average carrier power levels of +43 dBm each.

PHYSICAL DIMENSIONS:

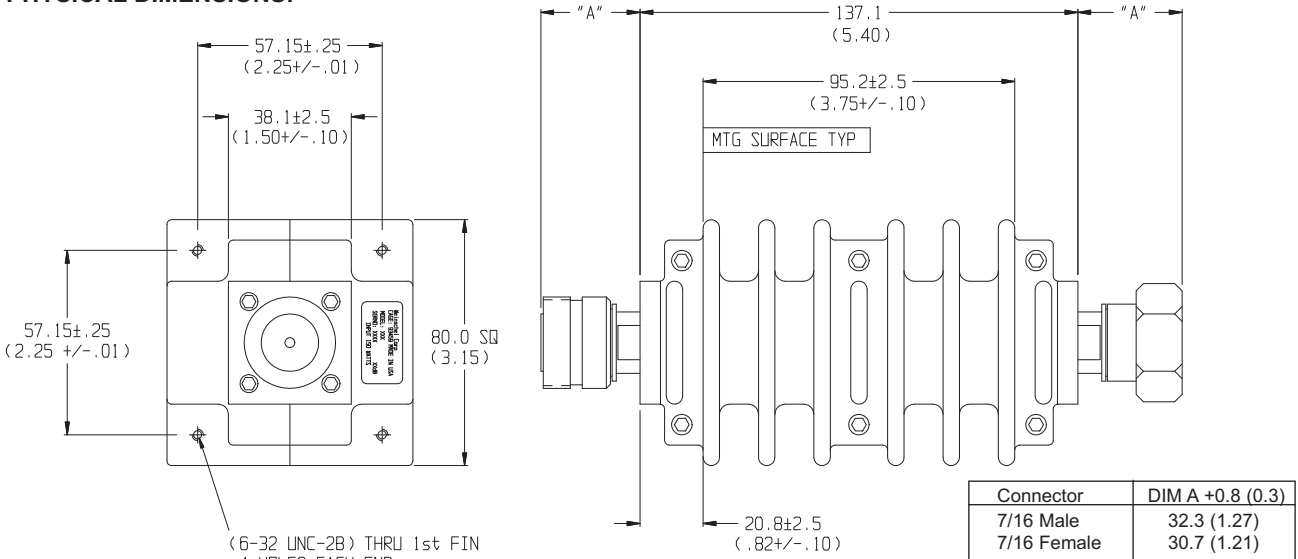

NOTE: All dimensions are given in mm (inches) and are maximum, unless otherwise specified.

POWER RATING (mounted horizontally): 150 watts average (unidirectional) to 25°C ambient temperature, derated linearly to 15 watts @ 125°C. 10 kilowatt peak (5 μsec pulse width; 0.75% duty cycle). Maximum power rating into output port is 20 watts average.

POWER COEFFICIENT: <0.0001 dB/dB/watt

TEMPERATURE COEFFICIENT: <0.0004 dB/dB/°C

TEMPERATURE RANGE: -55°C to 125°C

TEST DATA: Swept data plots of SWR from 50 MHz to 6 GHz is available at additional cost.

CONNECTORS: 7/16 connector that conforms to DIN 47223, IEC 169-4, VG 95250, CECC 22 190.

Connector Options	Type/Description
1	7/16 Female
2	7/16 Male

CONSTRUCTION: Black, finned aluminum body, silver plated brass connectors.

WEIGHT: 1,248 g (2.75 lbs.) maximum

MODEL NUMBER DESCRIPTION:

Example:

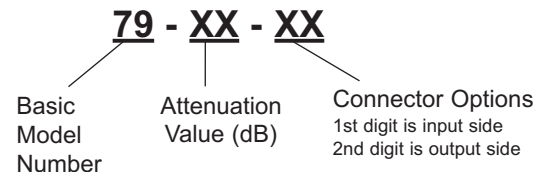

Fixed Coaxial Attenuators



Model 49 High Power, N Connectors Conduction/Convection Cooled

dc to 8.5 GHz
150 Watts

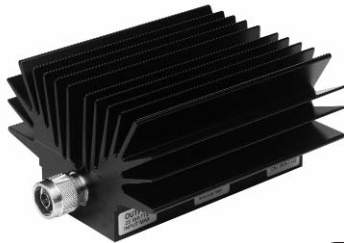

Features

- Quality connectors with special high temperature support beads.
- Designed to meet environmental requirements of MIL-DTL-3933.
- Flexible Mounting Position - The units may be mounted in horizontal (fins up) or vertical position.

Specifications

NOMINAL IMPEDANCE: 50 Ω

FREQUENCY RANGE: dc to 8.5 GHz

MAXIMUM DEVIATION OVER FREQUENCY (dB):				
Nominal ATTN (dB)	49		49-LIM	
	dc - 4 GHz	4 -8.5 GHz	dc - 4 GHz	4 -8.5 GHz
3, 6	± 0.50	± 1.00	---	---
10, 20	± 0.40	± 0.75	± 0.70	± 1.25
30	± 0.40	± 0.75	± 0.70	± 1.75
40	± 0.50	± 1.00	± 0.70	± 1.75

MAXIMUM SWR:	
Frequency (GHz)	SWR
dc - 4	1.25
4 - 8.5	1.35

3rd ORDER INTERMODULATION (49-XX-XX-LIM ONLY): Reflected Levels (IM3), -100 & Through Levels (IM3), -110 dBc with two input signals @ 869 MHz and 891 MHz with average carrier power levels of +43 dBm each.

POWER RATING (mounted horizontally or vertically): 150 watts average (unidirectional) to 25°C ambient temperature, derated linearly to 15 watts @ 125°C. 5 kilowatt peak (5 μsec pulse width; 1.5% duty cycle). Maximum power rating into output port is 25 watts average.

POWER COEFFICIENT: <0.0001 dB/dB/watt

TEMPERATURE COEFFICIENT: <0.0004 dB/dB/°C

TEMPERATURE RANGE: -55°C to 125°C

TEST DATA: Swept data plots of attenuation and SWR from 50 MHz to 8.5 GHz.

CONNECTORS: Type N connectors per MIL-STD-348 interface dimensions - mate nondestructively with MIL-C-39012 connectors.

Connector Options	Type/Description
3	Type N, Female
4	Type N, Male

CONSTRUCTION: Aluminum alloy body, stainless steel connectors; gold plated beryllium copper female contacts or stainless steel male contacts. (-LIM option uses different connector and contact materials)

WEIGHT: 1,450 g (3 lbs, 3 oz.) maximum

PHYSICAL DIMENSIONS:

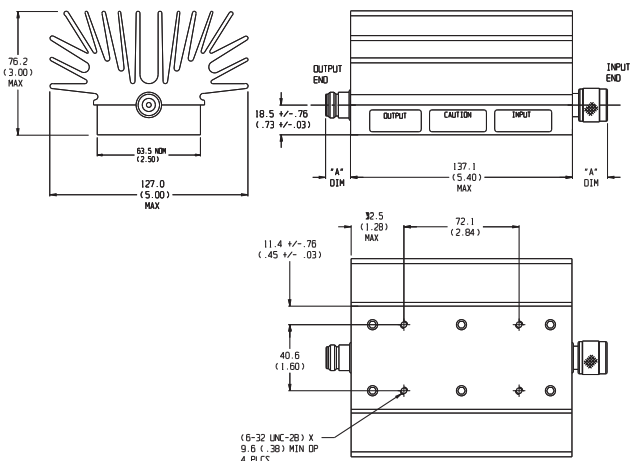

Connector	DIM A
N Male	22.9 (0.90)
N Female	15.0 (0.59)

NOTE: All dimensions are given in mm (inches) and are maximum, unless otherwise specified.

MODEL NUMBER DESCRIPTION:

Example:

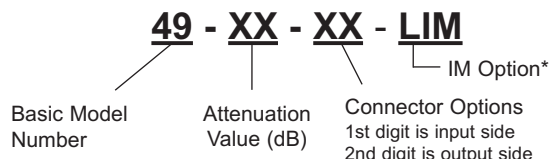

*Add -LIM for Low Intermodulation option. Option only available in 10, 20, 30, and 40 dB and is not available through Express.

Model 66 High Power, N or 3.5mm Connectors Convection Cooled

dc to 18.0 GHz
150 Watts



Features

- /// Quality injection molded connectors.
- /// Designed to meet environmental requirements of MIL-DTL-3933.
- /// Broadband performance, ideal for test applications.

Specifications

NOMINAL IMPEDANCE: 50 Ω

FREQUENCY RANGE: dc to 18.0 GHz

MAXIMUM DEVIATION OVER FREQUENCY:	
Nominal ATTN (dB)	Deviation (dB)
10	± 2.00
20, 30, 40	± 1.50

MAXIMUM SWR:		
Frequency (GHz)	10	20, 30, 40 dB
dc - 18	1.90	1.60

PHYSICAL DIMENSIONS:

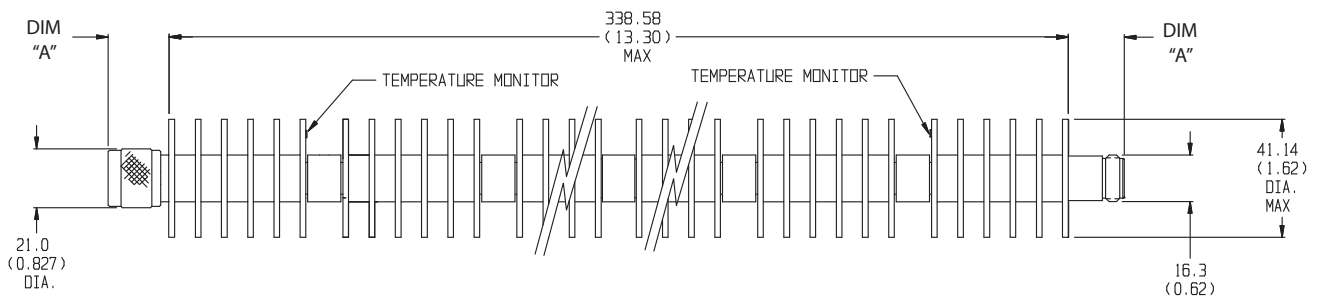

Connector	DIM A	Connector	DIM A
N Male	24.1 (0.95)	3.5mm Female	14.0 (0.55)
N Female	19.0 (0.75)	3.5mm Male	13.2 (0.52)

NOTE: All dimensions are given in mm (inches) and are maximum, unless otherwise specified.

POWER RATING (mounted horizontally): 150 watts average (unidirectional) @ case temperature of -55°C to +100 °C maximum. 1 kilowatt peak (5 μsec pulse width; 7.5% duty cycle). Maximum power rating into output port is 10 watts average.

POWER COEFFICIENT: <0.0001 dB/dB/watt

TEMPERATURE COEFFICIENT: <0.0004 dB/dB/°C

TEMPERATURE RANGE: -55°C to 100°C (case temp.)

TEST DATA: Swept data plots of attenuation and SWR from 50 MHz to 18 GHz.

CONNECTORS: Type N connectors per MIL-STD-348 interface dimensions - mate nondestructively with MIL-C-39012 connectors.

3.5mm Connectors - mate nondestructively with SMA per MIL-C-39012, 2.92mm and other 3.5mm connectors.

Options	Description	Options	Description
1	3.5mm Female	3	Type N Female
2	3.5mm Male	4	Type N Male

CONSTRUCTION: Aluminum alloy body, stainless steel connectors; gold plated beryllium copper contacts.

WEIGHT: 480 g (17 oz.) maximum

MODEL NUMBER DESCRIPTION:

Example:

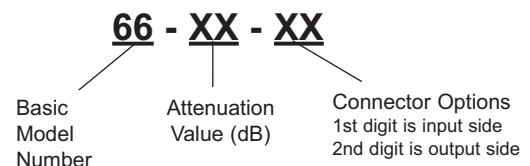

Fixed Coaxial Attenuators



Model 251 High Power, N Connectors Convection Cooled, Bi-directional



dc to 6.0 GHz
200 Watts

RoHS



Features

- Quality connectors with special high temperature support beads.
- Designed to meet environmental requirements of MIL-DTL-3933.

Specifications

NOMINAL IMPEDANCE: 50 Ω
FREQUENCY RANGE: dc to 6.0 GHz

MAXIMUM DEVIATION OVER FREQUENCY:

Nominal ATTN (dB)	Deviation (dB)
10, 20, 30, 40	± 2.00

MAXIMUM SWR:

Frequency (GHz)	SWR
dc - 2	1.10
2 - 6	1.20

POWER RATING: 200 watts **average (Bi-directional)** to 25°C ambient temperature, derated linearly to 20 watts @ 125°C ambient. 10 kilowatt **peak** (5 μsec pulse width; 1% duty cycle).

POWER COEFFICIENT: <0.0001 dB/dB/watt

TEMPERATURE COEFFICIENT: <0.0004 dB/dB/°C

TEMPERATURE RANGE: -55°C to 125°C

TEST DATA: Swept data plots of attenuation and SWR from 50 MHz to 6 GHz.

CONNECTORS: Type N connectors per MIL-STD-348 interface dimensions - mate nondestructively with MIL-C-39012 connectors.

Connector Options	Type/Description
3	Type N, Female
4	Type N, Male

CONSTRUCTION: Black Finned Aluminum alloy body, stainless steel connectors; gold plated beryllium copper contacts.

WEIGHT: 1,530 g (3 lbs, 6 oz) maximum

MODEL NUMBER DESCRIPTION:

Example:

251 - XX - XX

Basic Model Number

Attenuation Value (dB)

Connector Options
1st digit is input side
2nd digit is output side

PHYSICAL DIMENSIONS:

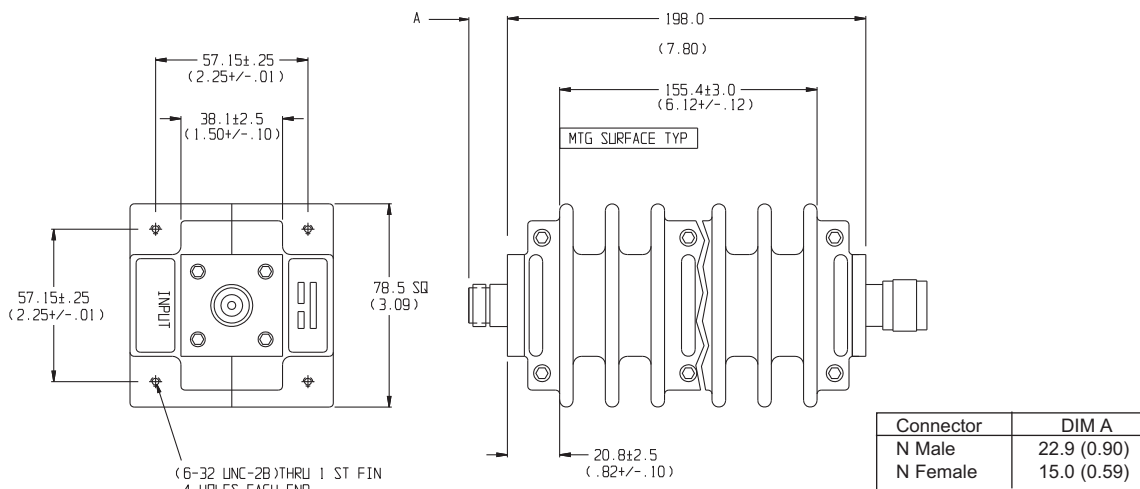

NOTE: All dimensions are given in mm (inches) and are maximum, unless otherwise specified.

Model 45

Model 58

High Power, N or SMK Connectors

Convection Cooled

dc to 1.5 GHz

dc to 6.0 GHz

250 Watts

RoHS



Features

- Quality connectors with special high temperature support beads.
- Designed to meet environmental requirements of MIL-DTL-3933.

Specifications

NOMINAL IMPEDANCE: 50 Ω

FREQUENCY RANGE: Model 45: dc to 1.5 GHz
Model 58: dc to 6.0 GHz

MAXIMUM DEVIATION OVER FREQUENCY:

Nominal ATTN (dB)	Deviation (dB)		
	45	58	58 LIM
3, 6	± 0.50	± 1.50	- - -
10, 20	± 0.50	± 1.50	± 2.00
30, 40	± 0.50	± 1.75	± 3.00

MAXIMUM SWR:

Frequency (GHz)	45/58		58 LIM	
	Input	Output	Input	Output
dc - 2 (1.5*)	1.10	1.20 (1.10*)	1.20	1.25
2 - 6	1.15	1.25	1.20	1.25

* Model 45 only!

3rd ORDER INTERMODULATION (58-XX-XX-LIM ONLY):

Reflected Levels (IM3), -100 & Through Levels (IM3), -110 dBc with two input signals @ 869 MHz and 891 MHz with average carrier power levels of +43 dBm each.

PHYSICAL DIMENSIONS:

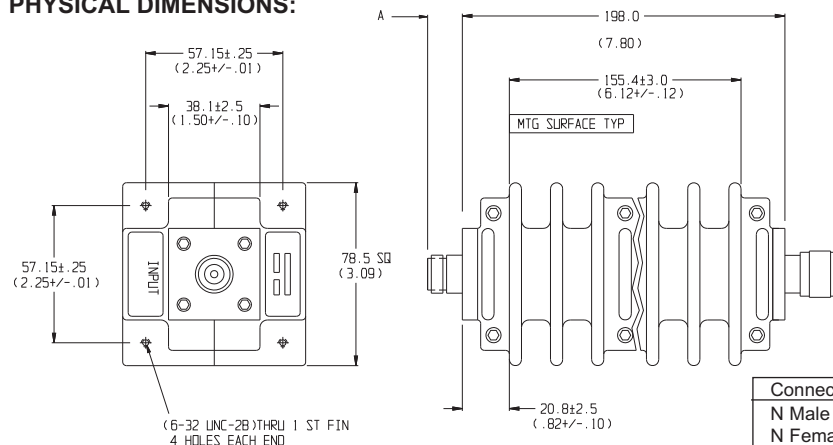

NOTE: All dimensions are given in mm (inches) and are maximum, unless otherwise specified.

Connector	DIM A	Connector	DIM A
N Male	22.9 (0.90)	2.92mm Male	14.0 (0.55)
N Female	15.0 (0.59)	2.92mm Female	12.7 (0.50)

POWER RATING (mounted horizontally with fins vertical): 250 watts average (unidirectional) to 55°C ambient temperature, derated linearly to 25 watts @ 125°C. 10 kilowatt peak (5 μsec pulse width; 1.25% duty cycle). Maximum power rating into output port is 50 watts average.

POWER COEFFICIENT: <0.0001 dB/dB/watt

TEMPERATURE COEFFICIENT: <0.0004 dB/dB/°C

TEMPERATURE RANGE: -55°C to 125°C

TEST DATA: Swept data plots of attenuation and SWR from 50 MHz to 1.5 / 6 GHz.

CONNECTORS: Type N connectors per MIL-STD-348 interface dimensions - mate nondestructively with MIL-C-39012 connectors. SMK (2.92mm) connectors - mate nondestructively with SMA per MIL-C-39012, 3.5mm, SMK, and other 2.92mm connectors.

Options	Description	Options	Description
1	SMK Female	3	Type N Female
2	SMK Male	4	Type N Male

CONSTRUCTION: Aluminum alloy body, stainless steel connectors; gold plated beryllium copper contacts.

WEIGHT: 1,530 g (3 lbs, 6 oz.) maximum

MODEL NUMBER DESCRIPTION:

Example:

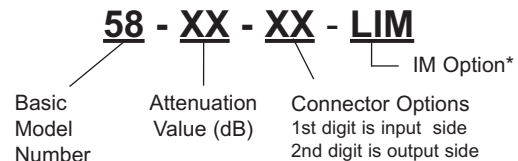

* Add -LIM for Low Intermodulation option. Option only available with Model 58 in 10, 20, 30, 40 dB and is not available through Express.

Model 67 High Power Fixed Coaxial Attenuator *Forced Cooled*

dc to 12.7 GHz
350 Watts



Features

- /// Precision Injection Molded Connectors.
- /// Designed to meet environmental requirements of MIL-DTL-3933.
- /// Broadband performance, ideal for test applications.

Specifications

NOMINAL IMPEDANCE: 50 Ω

FREQUENCY RANGE: dc to 12.7 GHz

MAXIMUM DEVIATION OVER FREQUENCY:

Nominal ATTN (dB)	Deviation (dB)	
	dc-8 GHz	8 -12.7 GHz
10	± 2.00	+6.00/-0.00
20, 30	± 2.50	+6.00/-0.00

MAXIMUM SWR:

Frequency (GHz)	SWR
dc - 8	1.30
8 - 12.7	1.60

POWER RATING (mounted horizontally): 350 watts average (unidirectional) @ 25°C ambient temperature. Case temperature must be held to **100°C maximum**. 5 kilowatt **peak** (5 μsec pulse width; 3.5% duty cycle). Maximum power rating into output port is 10 watts average.

TEMPERATURE COEFFICIENT: <0.0004 dB/dB/°C

TEMPERATURE RANGE: -55°C to 100°C (case temp.)

TEST DATA: Swept data plots of attenuation and SWR from 50 MHz to 12.7 GHz.

CONNECTORS: Type N connectors per MIL-STD-348 interface dimensions - mate nondestructively with MIL-C-39012 connectors.

Connector Options	Type/Description
3	Type N, Female
4	Type N, Male

CONSTRUCTION: Aluminum alloy body, stainless steel connectors; gold plated beryllium copper contacts.

WEIGHT: 1200 g (43 oz.) maximum

MODEL NUMBER DESCRIPTION:

Example:

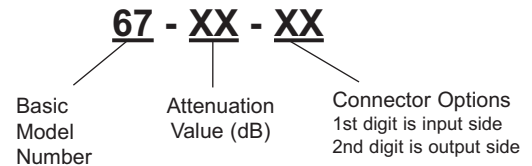

PHYSICAL DIMENSIONS:

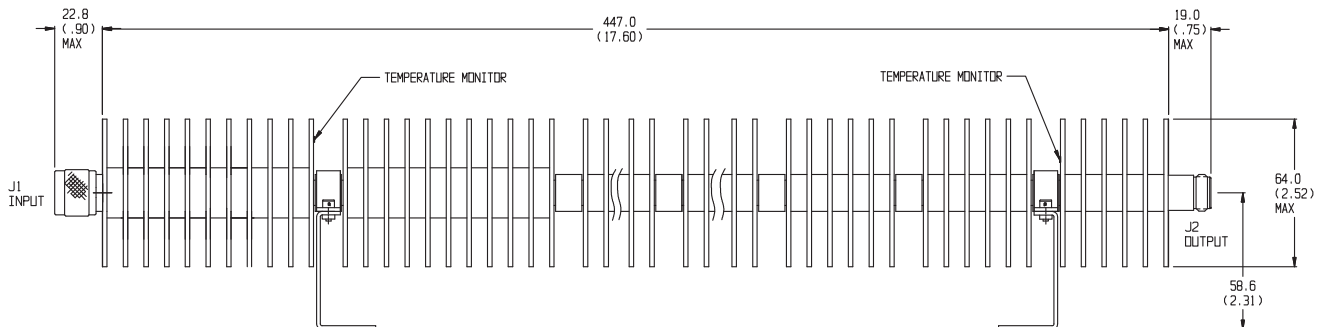

NOTE: All dimensions are given in mm (inches) and are maximum, unless otherwise specified.

Model 53 High Power, N Connectors Conduction/Convection Cooled

dc to 2.5 GHz
500 Watts

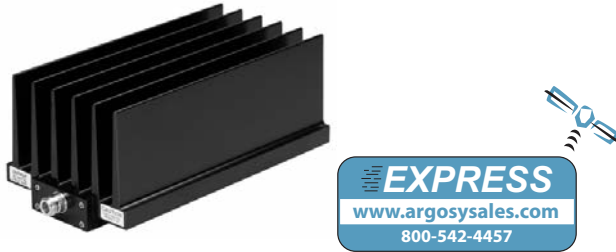

Features

- Quality connectors with special high temperature support beads.
- Designed to meet environmental requirements of MIL-DTL-3933.
- Flexible Mounting Position - The units may be mounted in horizontal (fins up) or vertical position.
- Low Intermodulation Distortion Option.

Specifications

NOMINAL IMPEDANCE: 50 Ω

FREQUENCY RANGE: dc to 2.5 GHz

MAXIMUM DEVIATION OVER FREQUENCY:

Nominal ATTN (dB)	Deviation (dB)	
	53	53 LIM
3, 6	± 1.00	---
10, 20, 30, 40	± 1.00	± 1.20

MAXIMUM SWR:

Frequency (GHz)	53	53 LIM
dc - 2.5	1.10	1.15

3rd ORDER INTERMODULATION (53-XX-XX-LIM ONLY): Reflected Levels (IM3), -100 & Through Levels (IM3), -110 dBc with two input signals @ 869 MHz and 891 MHz with average carrier power levels of +43 dBm each.

POWER RATING (mounted horizontally with fins vertical): 500 watts average (unidirectional) to 25°C ambient temperature, derated linearly to 50 watts @ 125°C. 10 kilowatt peak (5 μsec pulse width; 2.5% duty cycle). Maximum power rating into output port is 50 watts average.

TEMPERATURE COEFFICIENT: <0.0004 dB/dB/°C

TEMPERATURE RANGE: -55°C to 125°C

TEST DATA: Swept data plots of attenuation and SWR from 50 MHz to 2.5 GHz.

CONNECTORS: Type N connectors per MIL-STD-348 interface dimensions - mate nondestructively with MIL-C-39012 connectors.

Connector Options	Type/Description
3	Type N, Female
4	Type N, Male

CONSTRUCTION: Aluminum alloy body, gold plated beryllium copper contacts.

WEIGHT: 3,640 g (8 lbs.) maximum

PHYSICAL DIMENSIONS:

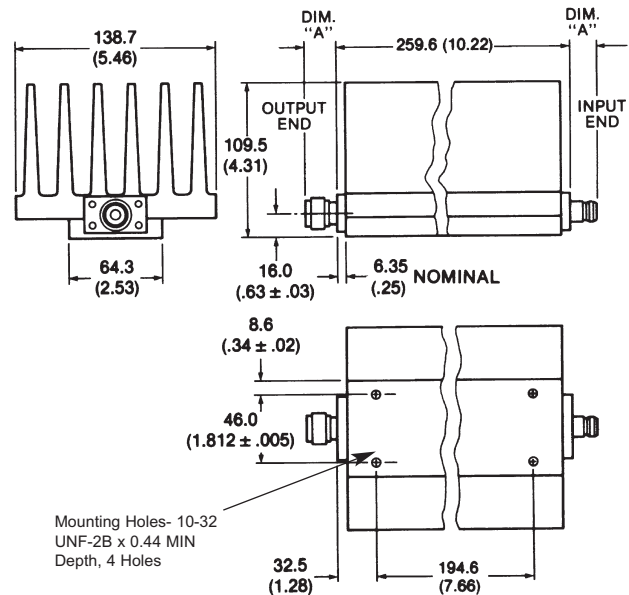

Connector	DIM A
N Male	22.9 (0.90)
N Female	15.0 (0.59)

NOTE: All dimensions are given in mm (inches) and are maximum, unless otherwise specified.

MODEL NUMBER DESCRIPTION:

Example:

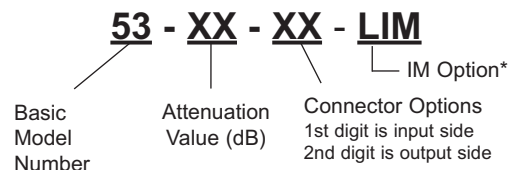

*Add -LIM for Low Intermodulation option. Option only available in 10, 20, 30 and 40 dB and is not available through Express.

Fixed Coaxial Attenuators



Model 81 High Power, N Connectors Conduction/Convection Cooled

dc to 10.0 GHz
500 Watts



Features

- Quality connectors with special high temperature support beads.
- Designed to meet environmental requirements of MIL-DTL-3933.

Specifications

NOMINAL IMPEDANCE: 50 Ω
FREQUENCY RANGE: dc to 10.0 GHz

MAXIMUM DEVIATION OVER FREQUENCY (dB):

NOM ATTN (dB)	Deviation	
	dc - 7.0 GHz	7.0 - 10.0 GHz
10, 20, 30, 40	±3.0	+5 / -0 dB

MAXIMUM SWR:

Frequency (GHz)	SWR
dc - 9.0	1.50
9.0 - 10.0	1.90

POWER RATING: 500 watts **average (unidirectional)** to 25°C ambient temperature, derated linearly to 50 watts @ 125°C. 5 kilowatt **peak** (5 μsec pulse width; 5% duty cycle). Maximum power into output is 20 Watts **average**.

TEMPERATURE COEFFICIENT: <0.0004 dB/dB/°C

TEMPERATURE RANGE: -55°C to +125°C

TEST DATA: Swept data plots of attenuation and SWR from 50 MHz to 10 GHz.

CONNECTOR: Type N connectors - mate nondestructively with MIL-C-39012 connectors.

Options	Type/Description
3	Type N, Female
4	Type N, Male

CONSTRUCTION: Black, finned aluminum body, stainless steel or connectors with gold plated beryllium copper contacts.

WEIGHT: 10 dB: 5.3 kg (11 lbs, 11 oz) maximum
20, 30, 40 dB: 6.24 Kg (13 lbs, 12 oz) maximum

PHYSICAL DIMENSIONS:

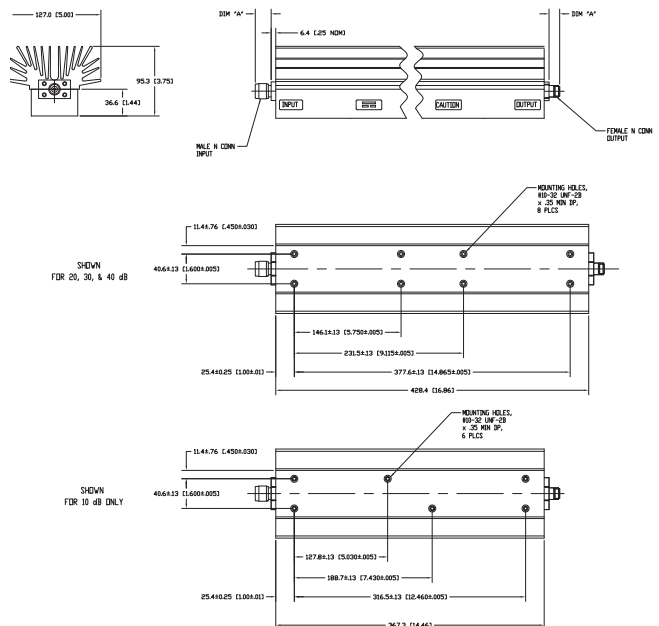

Connector Type	DIM A
N female	15.0 (0.59)
N male	22.9 (0.90)

NOTE: All dimensions are given in mm (inches) and are maximum, unless otherwise specified.

MODEL NUMBER DESCRIPTION:

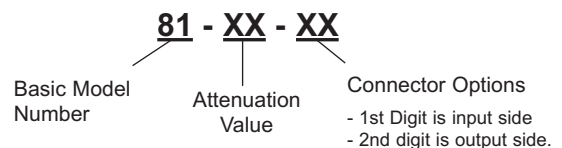

Model 82 High Power, N Connectors

dc to 3.0 GHz
1,000 Watts



Features

- Quality connectors with special high temperature support beads.
- Designed to meet environmental requirements of MIL-DTL-3933.

Specifications

NOMINAL IMPEDANCE: 50 Ω

FREQUENCY RANGE: dc to 3.0 GHz

MAXIMUM DEVIATION OVER FREQUENCY (dB):		
NOM ATTN (dB)	Deviation	
	dc - 1.5 GHz	1.5 - 3.0 GHz
10, 20, 30, 40	±1.0	+1.5, -1.0 dB

MAXIMUM SWR:	
Frequency (GHz)	SWR
dc - 1.5	1.15
1.5 - 3.0	1.25

PHYSICAL DIMENSIONS:

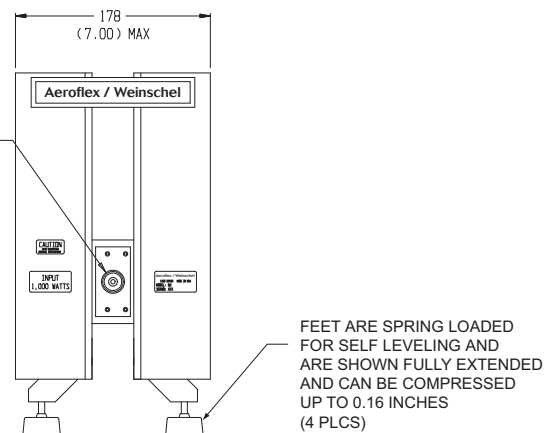
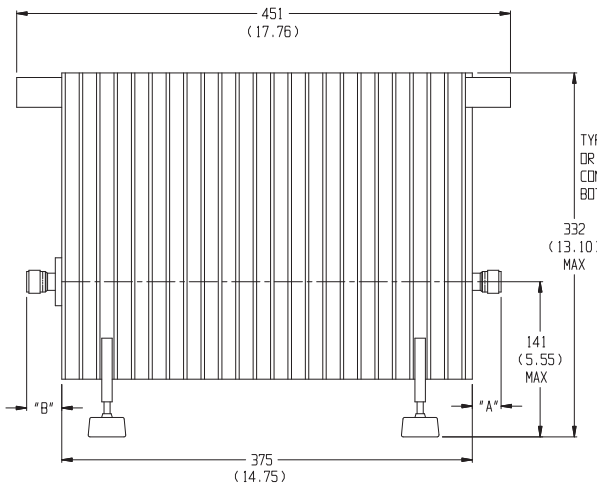

NOTE:

- All dimensions are given in mm (inches) and are maximum, unless otherwise specified.
- Unit available with RoHS compliant materials, specify when ordering.

POWER RATING: 1,000 watts **average** (unidirectional) to 25°C ambient temperature, derated linearly to 100 watts @ 125°C. 10 kilowatt **peak** (5 μsec pulse width; 5% duty cycle). Maximum power into output is 75 Watts **average**.

TEMPERATURE COEFFICIENT: <0.0004 dB/dB/°C

TEMPERATURE RANGE: -55°C to +125°C with power derating applied.

TEST DATA: Swept data plots of attenuation and SWR from 50 MHz to 3.0 GHz is available at additional cost.

CONNECTOR: Type N connectors - mate nondestructively with MIL-C-39012 connectors .

Options	Type/Description
3	Type N, Female
4	Type N, Male

CONSTRUCTION: Black, finned aluminum body, stainless steel with gold plated beryllium copper contacts.

WEIGHT: Net 13 kg (28.7 lbs) maximum

MODEL NUMBER DESCRIPTION:

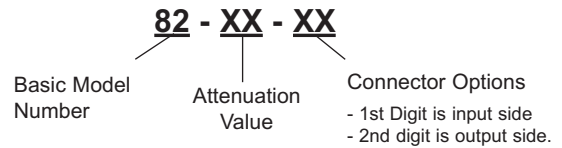

Connector Type	DIM A	DIM B
N female	15.0 (0.59)	21.4 (0.84)
N male	22.9 (0.90)	29.3 (1.15)

Fixed Coaxial Attenuators



Model 275 Medium Power, SMK Connectors Conduction Cooled, Bi-directional Design



dc to 40.0 GHz
5 Watts



Features

- /// Compact Construction - Lowest size/power ratio.
- /// Precision injection molded connectors.
- /// Designed to meet environmental requirements of MIL-DTL-3933.
- /// Flat Response & Low SWR.

Specifications

NOMINAL IMPEDANCE: 50 Ω
FREQUENCY RANGE: dc to 40.0 GHz

MAXIMUM DEVIATION OVER FREQUENCY:

Nominal ATTN (dB)	Deviation (dB)	
	dc-26.5 GHz	26.5-40 GHz
3	± 0.50	± 1.00
6, 10, 20, 30	± 0.80	± 1.50

MAXIMUM SWR:

Frequency (GHz)	SWR
dc - 26.5	1.25
26.5 - 40	1.45

POWER RATING: 5 watts **average (bi-directional)** with case temperature limited to 100 °C with appropriate conductive heat sink. 200 watts **peak** (5 μsec pulse width; 1.25% duty cycle).

POWER COEFFICIENT: <0.002 dB/dB/watt

TEMPERATURE COEFFICIENT: <0.0004 dB/dB/°C

TEMPERATURE RANGE: -55 °C to 100 °C (case)

TEST DATA: Swept data plots of attenuation and SWR from 50 MHz to 40 GHz.

CONNECTORS: SMK (2.92mm) Male/Female connectors - mate nondestructively with SMA per MIL-C-39012, 3.5mm and other 2.92mm connectors.

Connector Options	Type/Description
1	SMK, Female
2	SMK, Male

CONSTRUCTION: Aluminum body, gold plated beryllium copper contacts.

WEIGHT: 17 g (0.6 oz.) maximum

PHYSICAL DIMENSIONS:

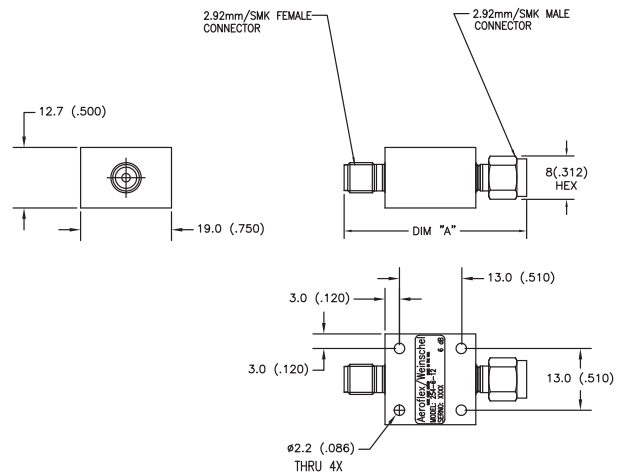

Dash No.	Connector Type	DIM A
11	2.92mm Female/Female	39.6 (1.56)
12	2.92mm Male/Female	44.2 (1.74)
22	2.92mm Male/Male	48.8 (1.92)

NOTE: All dimensions are given in mm (inches) and are nominal, unless otherwise specified.

MODEL NUMBER DESCRIPTION:

Example:

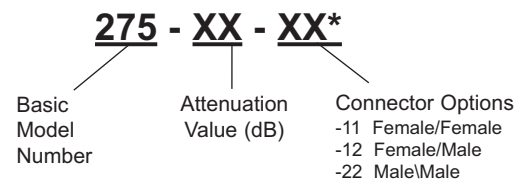

*Unit is bi-directional and full power may be applied to either connector.

Model 72 Medium Power, N or SMK Connectors Conduction Cooled, Bi-Directional Design!

dc to 4.0 GHz
50 Watts



Features

- /// **Compact Construction** - Lowest size/power ratio.
- /// **Precision Connectors with high temperature support beads.**
- /// **Designed to meet environmental requirements of MIL-DTL-3933.**
- /// **Wireless Applications** - Optimized for use in the communications bands.

Specifications

NOMINAL IMPEDANCE: 50 Ω

FREQUENCY RANGE: dc to 4.0 GHz

MAXIMUM DEVIATION OVER FREQUENCY:

Nominal ATTN (dB)	Deviation (dB)
3, 6, 10, 20, 30, 40	± 0.70

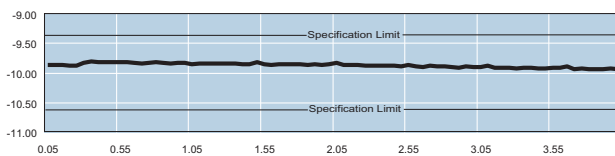

Typical Attenuation Accuracy of a 72-10-34

MAXIMUM SWR:

Frequency (GHz)	SWR
dc - 4	1.20

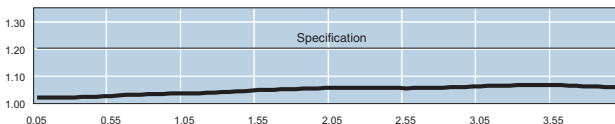

Typical SWR of a 72-10-34

POWER RATING 50 watts **average (bi-directional)**, 5 kilowatts **peak** (5 μsec pulse width; 0.5 % duty cycle) with case temperature held within **100°C maximum** with appropriate conductive heat sink.

POWER COEFFICIENT: <0.0003 dB/dB/watt

TEMPERATURE COEFFICIENT: <0.0004 dB/dB/°C

TEMPERATURE RANGE: -55°C to 100°C (case)

TEST DATA: Swept data plots of attenuation and SWR from 50 MHz to 4 GHz is available at additional cost.

CONNECTORS: Type N connectors per MIL-STD-348 interface dimensions - mate nondestructively with MIL-C-39012 connectors. SMK (2.92mm) connectors - mate nondestructively with SMA per MIL-C-39012, 3.5mm, SMK, and other 2.92mm connectors.

Options	Description	Options	Description
1	SMK Female	3	Type N Female
2	SMK Male	4	Type N Male

CONSTRUCTION: Aluminum body, stainless steel connectors; gold plated beryllium copper contacts.

WEIGHT: 170 g (6 oz.) maximum

PHYSICAL DIMENSIONS:

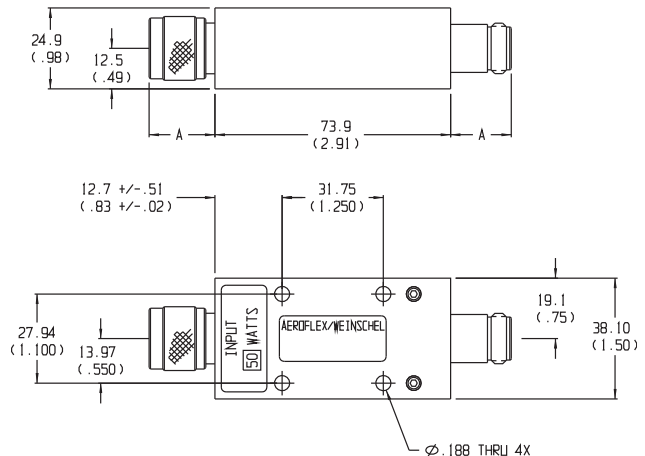

Connector	DIM A	Connector	DIM A
N Male	22.9 (0.90)	2.92mm Male	14.0 (0.55)
N Female	15.0 (0.59)	2.92mm Female	12.7 (0.50)

NOTE: All dimensions are given in mm (inches) and are maximum, unless otherwise specified.

MODEL NUMBER DESCRIPTION:

Example:

72 - XX - XX*

Basic Model Number

Attenuation Value (dB)

Connector Options
1st digit is J1 side
2nd digit is J2 side

*Unit is bi-directional & full power may be applied to either J1 or J2.

Model 284 Medium Power, N or SMK Connectors Conduction Cooled, Bi-Directional Design!

dc to 10.0 GHz
50 Watts



Features

- /// **Compact Construction** - Lowest size/power ratio.
- /// **Precision Connectors with high temperature support beads.**
- /// **Designed to meet environmental requirements of MIL-DTL-3933.**
- /// **Wireless Applications** - Optimized for use in the communications bands.

Specifications

NOMINAL IMPEDANCE: 50 Ω

FREQUENCY RANGE: dc to 10.0 GHz

MAXIMUM DEVIATION OVER FREQUENCY (dB):		
Nominal ATTN (dB)	DC-4 GHz	4-10 GHz
3, 6, 10, 20	± 0.40	± 0.75
30, 40	± 0.60	± 1.00

MAXIMUM SWR:	
Frequency (GHz)	SWR
dc - 4	1.15
4 - 10	1.30

POWER RATING 50 watts **average (bi-directional)**, 5 kilowatts **peak** (5 μsec pulse width; 0.5 % duty cycle) with case temperature held within **100°C maximum** with appropriate conductive heat sink.

POWER COEFFICIENT: <0.0003 dB/dB/watt

TEMPERATURE COEFFICIENT: <0.0004 dB/dB/°C

TEMPERATURE RANGE: -55°C to 100°C (case)

TEST DATA: Swept data plots of attenuation and SWR from 50 MHz to 10 GHz.

CONNECTORS: Type N connectors per MIL-STD-348 interface dimensions - mate nondestructively with MIL-C-39012 connectors. SMK (2.92mm) connectors - mate nondestructively with SMA per MIL-C-39012, 3.5mm, SMK, and other 2.92mm connectors.

Options	Description	Options	Description
1	SMK Female	3	Type N Female
2	SMK Male	4	Type N Male

CONSTRUCTION: Aluminum body, stainless steel connectors; gold plated beryllium copper contacts.

WEIGHT: 170 g (6 oz.) maximum

PHYSICAL DIMENSIONS:

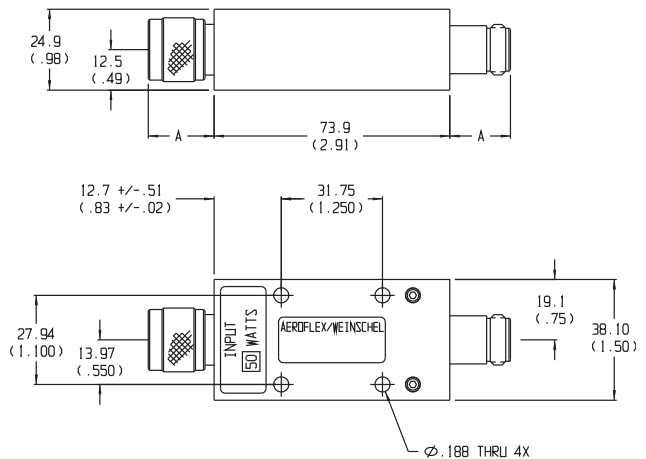

Connector	DIM A	Connector	DIM A
N Male	22.9 (0.90)	2.92mm Male	14.0 (0.55)
N Female	15.0 (0.59)	2.92mm Female	12.7 (0.50)

NOTE: All dimensions are given in mm (inches) and are maximum, unless otherwise specified.

MODEL NUMBER DESCRIPTION:

Example:

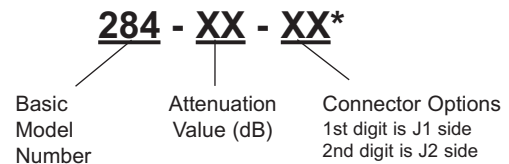

*Unit is bi-directional & full power may be applied to either J1 or J2.

Fixed Coaxial Attenuators



Model 86 Medium Power, 3.5mm Connectors Conduction Cooled, Bi-directional Design

dc to 22.0 GHz
50 Watts



CONSTRUCTION: Aluminum body, stainless steel connectors; gold plated beryllium copper contacts.

WEIGHT: 60 g (2.1 oz.) maximum

PHYSICAL DIMENSIONS:

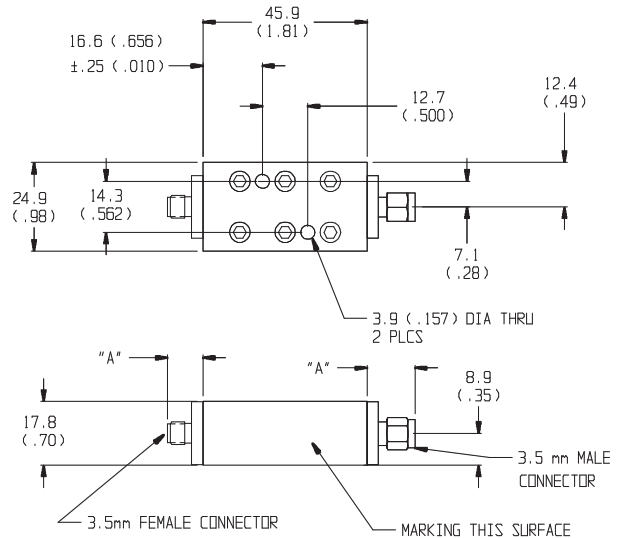

Features

- /// **Compact Construction** - Lowest size/power ratio.
- /// **Precision Injection Molded Connectors.**
- /// **Designed to meet environmental requirements of MIL-DTL-3933.**
- /// **Ideal for Airborne or Space Applications.**

Specifications

NOMINAL IMPEDANCE: 50 Ω
FREQUENCY RANGE: dc to 22.0 GHz

MAXIMUM DEVIATION OVER FREQUENCY:

Nominal ATTN (dB)	Deviation (dB)
3, 6, 10, 20, 30	± 0.80

MAXIMUM SWR: 1.30

POWER RATING 50 watts **average (bi-directional)**, 1 kilowatts **peak** (5 μsec pulse width; 2.5 % duty cycle) with case temperature held within **90°C maximum** with appropriate conductive heat sink.

POWER COEFFICIENT: <0.0003 dB/dB/watt

TEMPERATURE COEFFICIENT: <0.0004 dB/dB/°C

TEMPERATURE RANGE: -55°C to 90°C (case)

TEST DATA: Swept data plots of attenuation and SWR from 50 MHz to 22 GHz.

CONNECTORS: 3.5mm connectors - mate nondestructively with SMA per MIL-C-39012, 2.92mm and other 3.5mm connectors.

Options	Description
1	3.5mm Female
2	3.5mm Male

Connector	DIM A
3.5mm Male	13.4±0.5 (0.53±0.02)
3.5mm Female	9.9±0.5 (0.32±0.02)

NOTE: All dimensions are given in mm (inches) and are nominal, unless otherwise specified.

MODEL NUMBER DESCRIPTION:

Example:

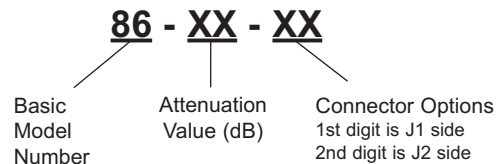

*Unit is bi-directional and full power may be applied to either J1 or J2.

Model 59 High Power, N or SMK Connectors Conduction Cooled

dc to 2.5 GHz
100 Watts



Features

- /// Precision Connectors with high temperature support beads.
- /// Designed to meet environmental requirements of MIL-DTL-3933.
- /// 10 Kilowatts peak, Conductive Cooled
- /// Wireless Applications - Optimized for use in the communications bands.

Specifications

NOMINAL IMPEDANCE: 50 Ω

FREQUENCY RANGE: dc to 2.5 GHz

MAXIMUM DEVIATION OVER FREQUENCY:

Nominal ATTN (dB)	Deviation (dB)	
	dc-1 GHz	1-2.5 GHz
3, 6, 10, 20, 30, 40	± 0.70	± 1.00

MAXIMUM SWR:

Frequency (GHz)	SWR
dc - 2.5	1.15

POWER RATING 100 watts **average (unidirectional)**, 10 kilowatts **peak** (5 μsec pulse width; 0.5 % duty cycle) with case temperature held within **100 °C maximum** with appropriate conductive heat sink. Note: 3 dB model can handle 200 Watts **average (unidirectional)**. Maximum power rating into output port is 10 % of the average power rating.

POWER COEFFICIENT: <0.00015 dB/dB/watt

TEMPERATURE COEFFICIENT: <0.0004 dB/dB/°C

TEMPERATURE RANGE: -55°C to 100°C (case temp)

TEST DATA: Swept data plots of attenuation and SWR from 50 MHz to 2.5 GHz.

CONNECTORS: Type N connectors per MIL-STD-348 interface dimensions - mate nondestructively with MIL-C-39012 connectors. SMK (2.92mm) connectors mate with SMA, 3.5mm and other 2.92mm connectors.

Options	Description	Options	Description
1	SMK Female	3	Type N Female
2	SMK Male	4	Type N Male

CONSTRUCTION: Aluminum alloy body, stainless steel connectors; gold plated beryllium copper contacts.

WEIGHT: 300 g (10.6 oz.) maximum

PHYSICAL DIMENSIONS:

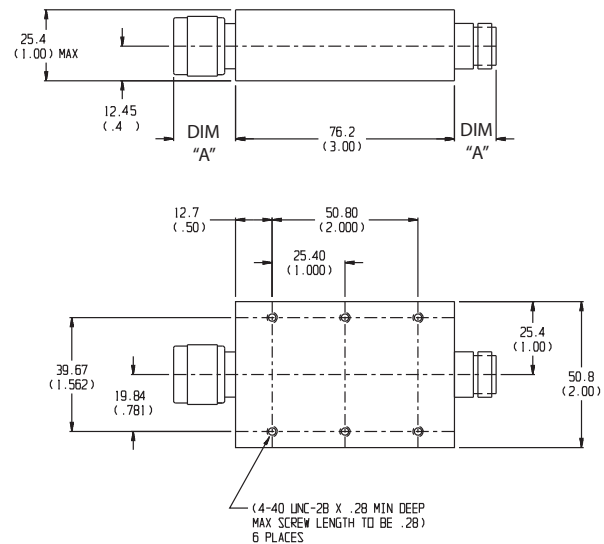

Connector	DIM A	Connector	DIM A
N Male	22.9 (0.90)	2.92mm Male	14.0 (0.55)
N Female	15.0 (0.59)	2.92mm Female	12.7 (0.50)

NOTE: All dimensions are given in mm (inches) and tolerances are .X±0.5 (0.02) & .XX±0.25 (0.01), unless otherwise specified.

MODEL NUMBER DESCRIPTION:

Example:

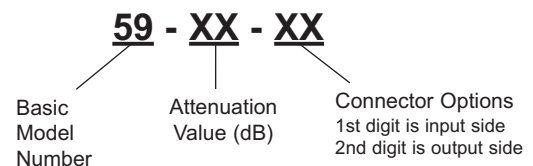

Fixed Coaxial Attenuators



Model 268 High Power, N or SMK Connectors Conduction Cooled



dc to 6.0 GHz
100 Watts
 RoHS



Features

- /// Precision Connectors with high temperature support beads.
- /// Designed to meet environmental requirements of MIL-DTL-3933.
- /// 10 Kilowatts peak, Conduction Cooled
- /// Wireless Applications - Optimized for use in the communications bands.

Specifications

NOMINAL IMPEDANCE: 50 Ω

FREQUENCY RANGE: dc to 6.0 GHz

MAXIMUM DEVIATION OVER FREQUENCY:

Nominal ATTN (dB)	Deviation (dB)
10, 20, 30, 40	± 1.00

MAXIMUM SWR:

Frequency (GHz)	SWR
dc - 2.5	1.10
2.5 - 6	1.15

3rd ORDER INTERMODULATION (268-XX-XX-LIM ONLY): Reflected Levels (IM3), -100 & Through Levels (IM3), -110 dBc with two input signals @ 869 MHz and 891 MHz with average carrier power levels of +43 dBm each.

POWER RATING (mounted horizontally): 100 watts average (unidirectional), 10 kilowatt peak (5 μsec pulse width; 0.5% duty cycle) with case temperature held within **100 °C maximum** with appropriate conductive heat sink.

POWER COEFFICIENT: <0.00015 dB/dB/watt

TEMPERATURE COEFFICIENT: <0.0004 dB/dB/°C

TEMPERATURE RANGE: -55 to 100°C (case temperature)

TEST DATA: Swept data plots of attenuation and SWR from 50 MHz to 6 GHz.

CONNECTORS: Type N connectors per MIL-STD-348 interface dimensions - mate nondestructively with MIL-C-39012 connectors. SMK (2.92mm) connectors mate with SMA, 3.5mm and other 2.92mm connectors.

Options	Description	Options	Description
1	SMK Female	3	Type N Female
2	SMK Male	4	Type N Male

CONSTRUCTION: Aluminum alloy body, stainless steel connectors; gold plated beryllium copper contacts.

WEIGHT: 300 g (10.6 oz.) maximum

PHYSICAL DIMENSIONS:

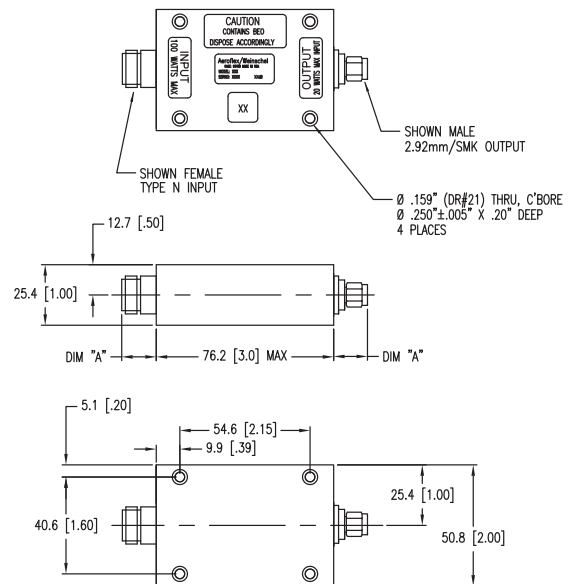

Connector	DIM A	Connector	DIM A
N Male	22.9 (0.90)	2.92mm Male	14.0 (0.55)
N Female	15.0 (0.59)	2.92mm Female	12.7 (0.50)

NOTE: All dimensions are given in mm (inches) and are nominal, unless otherwise specified.

MODEL NUMBER DESCRIPTION:

Example:

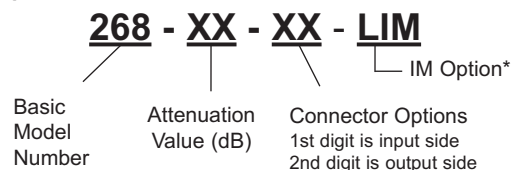

* Add -LIM for Low Intermodulation option.

Model 257 High Power, N or SMK Connectors Conduction Cooled



dc to 6.0 GHz
250 Watts



Features

- /// Precision Connectors with high temperature support beads.
- /// Designed to meet environmental requirements of MIL-DTL-3933.
- /// 10 Kilowatts peak, Conduction Cooled
- /// Wireless Applications - Optimized for use in the communications bands.

Specifications

NOMINAL IMPEDANCE: 50 Ω

FREQUENCY RANGE: dc to 6.0 GHz

MAXIMUM DEVIATION OVER FREQUENCY:

Nominal ATTN (dB)	Deviation (dB)
10, 20, 30, 40	± 1.00

MAXIMUM SWR:

Frequency (GHz)	SWR
dc - 2.5	1.10
2.5 - 6	1.15

3rd ORDER INTERMODULATION (257-XX-XX-LIM ONLY): Reflected Levels (IM3), -100 & Through Levels (IM3), -110 dBc with two input signals @ 869 MHz and 891 MHz with average carrier power levels of +43 dBm each.

POWER RATING: 250 watts **average (unidirectional)**, 10 kilowatt **peak** (5 μsec pulse width; 1.25% duty cycle) with case temperature held within **100 °C maximum** with appropriate conductive heat sink. Maximum power rating into output port is 40 watts average.

TEMPERATURE COEFFICIENT: <0.0004 dB/dB/°C

TEMPERATURE RANGE: -55 to 100°C (case temperature)

TEST DATA: Swept data plots of attenuation and SWR from 50 MHz to 6 GHz.

CONNECTORS: Type N connectors per MIL-STD-348 interface dimensions - mate nondestructively with MIL-C-39012 connectors. SMK (2.92mm) connectors mate with SMA, 3.5mm and other 2.92mm connectors.

Options	Description	Options	Description
1	SMK Female	3	Type N Female
2	SMK Male	4	Type N Male

CONSTRUCTION: Aluminum alloy body, stainless steel connectors; gold plated beryllium copper contacts.

WEIGHT: 500 g (17.6 oz.) maximum

PHYSICAL DIMENSIONS:

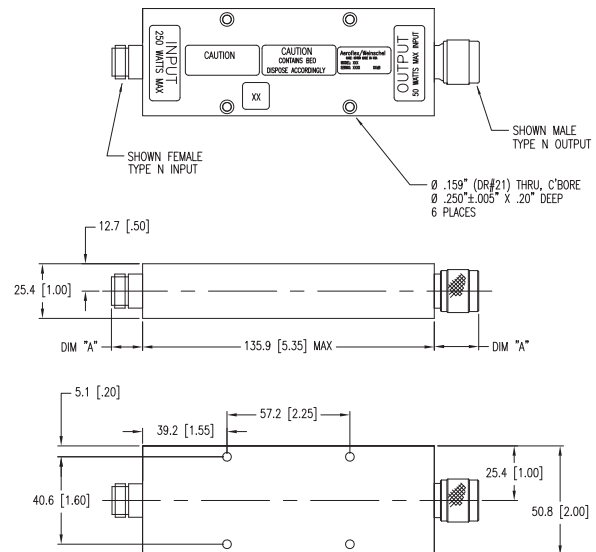

Connector	DIM A	Connector	DIM A
N Male	22.9 (0.90)	2.92mm Male	14.0 (0.55)
N Female	15.0 (0.59)	2.92mm Female	12.7 (0.50)

NOTE: All dimensions are given in mm (inches) and are maximum, unless otherwise specified.

MODEL NUMBER DESCRIPTION:

Example:

257 - XX - XX - LIM
IM Option*

Basic Model Number Attenuation Value (dB) Connector Options
1st digit is input side
2nd digit is output side

* Add -LIM for Low Intermodulation option.

Model 253 High Power, N or SMK Connectors Conduction Cooled



dc to 6 GHz
550 Watts



Features

- /// Precision Connectors with high temperature support beads.
- /// Designed to meet environmental requirements of MIL-DTL-3933.
- /// 10 Kilowatts peak, Conduction Cooled
- /// Wireless Applications - Optimized for use in the communications bands.

Specifications

NOMINAL IMPEDANCE: 50 Ω
FREQUENCY RANGE: dc to 6.0 GHz

MAXIMUM DEVIATION OVER FREQUENCY:

Nominal ATTN (dB)	Deviation (dB)
10, 20, 30, 40	± 1.50

MAXIMUM SWR:

Frequency (GHz)	SWR
dc - 2.5	1.10
2.5 - 6	1.20

3rd ORDER INTERMODULATION (253-XX-XX-LIM ONLY): Reflected Levels (IM3), -100 & Through Levels (IM3), -110 dBc with two input signals @ 869 MHz and 891 MHz with average carrier power levels of +43 dBm each.

POWER RATING: 550 watts **average (unidirectional)**, 10 kilowatt **peak** (5 μsec pulse width; 2.5% duty cycle) with case temperature held within **100 °C maximum** with appropriate conductive heat sink. Maximum power into output is 50 Watts **average**.

TEMPERATURE COEFFICIENT: <0.0004 dB/dB/°C

TEMPERATURE RANGE: -55 to 100°C (case temperature)

TEST DATA: Swept data plots of attenuation and SWR from 50 MHz to 6 GHz.

CONNECTORS: Type N connectors per MIL-STD-348 interface dimensions - mate nondestructively with MIL-C-39012 connectors. SMK (2.92mm) connectors mate with SMA, 3.5mm and other 2.92mm connectors.

Options	Description	Options	Description
1	SMK Female	3	Type N Female
2	SMK Male	4	Type N Male

CONSTRUCTION: Aluminum alloy body, gold plated beryllium copper contacts.

WEIGHT: 900 (31.3 oz.) maximum

PHYSICAL DIMENSIONS:

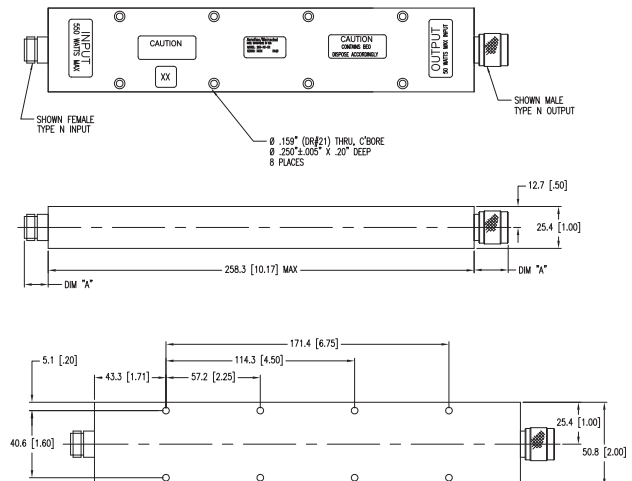

Connector	DIM A	Connector	DIM A
N Male	22.9 (0.90)	2.92mm Male	14.0 (0.55)
N Female	15.0 (0.59)	2.92mm Female	12.7 (0.50)

NOTE: All dimensions are given in mm (inches) and are maximum, unless otherwise specified.

MODEL NUMBER DESCRIPTION:

Example:

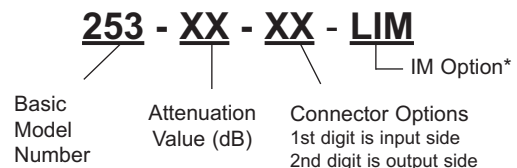

* Add -LIM for Low Intermodulation option.

Terminations & Loads



- /// dc to 50 GHz, up to 1,000 Watts
- /// Choice of frequency ranges, attenuation value and power level.
- /// **Express** shipment available on most models.
- /// Consistent, repeatable performance.
- /// High reliability.
- /// Rugged injection molded connectors.
- /// Low Intermodulation (LIM) versions available
- /// Custom performance and connector options available.

General Information

In this section of the catalog, each Termination is outlined utilizing individual data sheets containing product features, specifications, and outline drawings. These data sheets are preceded by a quick reference guide to help you select the Termination(s) that fits your needs. The page number for each Termination data sheet is given in the quick reference guide.











Aeroflex / Weinschel offers a full line of coaxial terminations and loads. Our terminations and loads can be found in almost every phase of microwave industry from simple directional coupler port termination to the design measurement and wireless communications systems.

NOTE: **EXPRESS** Shipment available via www.argosysales.com or 800-542-4457. Check with distributor for current products and stocking quantities.



Terminations . . . dc-50 GHz, 1 to 5 Watts



Model Number	Frequency Range (GHz)	Average Power (Watts)	Peak Power (kW)	SWR	Connector Type	Page No.	
♦ 1404N	dc-18.0	1	1	1.02-1.08*	N	91	
♦ 1406A ♦ 1408	dc-18.0	2	0.5	1.05-1.21* 1.04-1.15*	SMA	92	
♦ RS3016	dc-18.0	1	0.25	1.05-1.20*	SMA (Male only)	90	
♦ 1424	dc-12.4	5	5	1.03-1.30*	N	97	
♦ F1437RA M1437RA	dc-6.0	2	0.25	1.05-1.10* 1.15-1.20*	SMA (Female) SMA (Male)	90	
♦ 1443A	dc-18.0	5	0.5	1.20	SMA	98	
1445A	dc-40.0	5	0.2	1.20-1.35*	2.92mm	99	
♦ 1455	dc-18.0	2	1	1.20-1.30*	N	93	
♦ 1459/A	dc-40.0	2	0.5	1.10-1.25*	2.92mm	95	
1460/A	dc-50.0	2	0.5	1.10-1.22*	2.4mm	96	
1465/A	dc-32.0	2	0.5	1.06-1.15*	3.5mm	94	

* VARIES WITH FREQUENCY.

- ♦ EXPRESS Shipment available via www.argosysales.com or 800-542-4457.
Note: Other models may also be available from Express delivery.

Terminations & Loads

Medium Power . . . dc-26.5 GHz, 10 to 50 Watts



Model Number	Frequency Range (GHz)	Average Power (Watts)	Peak Power (kW)	SWR	Connector Type	Page No.	
♦ 1418	dc-18.0	10	1	1.15-1.40*	N	103	
♦ 1419	dc-18.0	10	1	1.20-1.35*	SMA	100	
♦ 1425	dc-12.4	10	1	1.03-1.40*	N	102	
♦ 1426	dc-10.0	50	5	1.20-1.30*	SMK (2.92mm) / N	111	
♦ 1427	dc-10.0	25	5	1.10-1.30*	SMK (2.92mm) / N	106	
♦ 1429	dc-18.0	25	1	1.20	N / 3.5mm	107	
♦ 1430	dc-18.0	50	1	1.15-1.30*	N / 3.5mm	112	
♦ 1444	dc-26.5	25	0.5	1.25	3.5mm	108	
1446	dc-6.0	25	5	1.20	7/16	105	
1447	dc-6.0	50	5	1.20	7/16	110	
♦ 1452	dc-4.0	25	5	1.10-1.20*	SMK (2.92mm) / N	104	
♦ 1453	dc-8.5	10	1	1.15-1.25*	N	101	
1467	dc-20.0	50	1	1.15-1.20*	3.5mm / N	113	
1468 <i>New</i>	dc-3.0	50	1		BNC / SMA N	109	
1477 <i>New</i>	dc-40.0	10	0.2	1.20-1.35*	SMK (2.92mm)	103a	
1478 <i>New</i>	dc-40.0	20	0.2	1.20-1.35*	SMK (2.92mm)	103b	

* VARIES WITH FREQUENCY.

- ♦ EXPRESS Shipment available via www.argosysales.com or 800-542-4457. Note: Other models may also be available from Express delivery.

High Power . . . dc-18 GHz, 100-1000 Watts



Model Number	Frequency Range (GHz)	Average Power (Watts)	Peak Power (kW)	SWR	Connector Type	Page No.	
♦ 1428	dc-1.5	150	10	1.10-1.15*	N	119	
♦ 1431	dc-18.0	100	1	1.20-1.30*	N / 3.5mm	116	
1432	dc-8.5	150	5	1.20-1.30*	N	121	
♦ 1433	dc-5.0	250	10	1.10-1.15*	N	122	
♦ 1434	dc-2.5	500	10	1.10	N	123	
♦ 1435	dc-5.0	150	10	1.10-1.15*	N	119	
♦ 1439	dc-2.5	150	10	1.20	N	118	
♦ 1440	dc-4.0	100	10	1.15	N	114	
1442	dc-8.5	100	5	1.20-1.30*	N	115	
1448	dc-6.0	150	10	1.25	7/16	120	
1456	dc-3.0	1,000	10	1.15-1.25*	N	124	
1469 <i>New</i>	dc-18.0	100	1	1.15	N / 3.5mm	117	
1475 <i>New</i>	dc-18.0	150	1	1.90	N / 3.5mm	121a	

* VARIES WITH FREQUENCY.

- ♦ EXPRESS Shipment available via www.argosysales.com or 800-542-4457.
Note: Other models may also be available from Express delivery.

Terminations & Loads









Low IMD . . . dc-20 GHz, 25 to 500 Watts

Model Number	Frequency Range (GHz)	Average Power (Watts)	Peak Power (kW)	SWR	Connector Type	Page No.	
1426-X-LIM	dc-8.5	50	5	1.20-1.30*	SMK (2.92mm) / N	111	
1427-X-LIM	dc-10.0	25	5	1.10-1.15*	SMK (2.92mm) / N	106	
1429-X-LIM	dc-18.0	25	1	1.20	N / 3.5mm	107	
1430-X-LIM	dc-18.0	50	1	1.15-1.30*	N / 3.5mm	112	
1435-X-LIM	dc-5.0	150	5	1.10-1.15*	N	119	
1432-X-LIM	dc-8.5	150	5	1.20-1.30*	N	121	
1433-X-LIM	dc-5.0	250	10	1.10-1.15*	N	122	
1434-X-LIM	dc-2.5	500	10	1.10	N	123	
1446	dc-6.0	25	5	1.20	7/16	105	
1447	dc-6.0	50	5	1.20	7/16	110	
1448	dc-6.0	150	10	1.25	7/16	120	
1469-X-LIM <i>New</i>	dc-18.0	100	1	1.15-1.20	N / 3.5mm	117	
1470-X-LIM <i>New</i>	dc-6	100	1	1.20	SMK (2.92mm) / N	128	
1471-X-LIM <i>New</i>	dc-6	250	1	1.20	SMK (2.92mm) / N	129	
1472-X-LIM <i>New</i>	dc-6	400	1	1.20	SMK (2.92mm) / N	130	
1473-X-LIM <i>New</i>	dc-6	550	1	1.20	SMK (2.92mm)	131	
1475-X-LIM <i>New</i>	dc-18.0	150	1	1.90	N / 3.5mm / N	121a	

Convection Cooled . . . dc-22 GHz, 50-550 Watts



Model Number	Frequency Range (GHz)	Average Power (Watts)	Peak Power (kW)	SWR	Connector Type	Page No.	
♦ 1441	dc-4.0	50	5	1.15	N	126	
1458	dc-22.0	50	1	1.30	3.5mm	127	
1470 <i>New</i>	dc-6.0	100	1	1.20	SMK (2.92mm) / N	128	
1471 <i>New</i>	dc-6.0	250	1	1.20	SMK (2.92mm) / N	129	
1472 <i>New</i>	dc-6.0	400	1	1.20	SMK (2.92mm) / N	130	
1473 <i>New</i>	dc-6.0	550	1	1.20	SMK (2.92mm) / N	131	
1474 <i>New</i>	dc-40.0	5	1	1.25-1.45	SMK (2.92mm)	125	
1476 <i>New</i>	dc-10.0	50	5	1.15-1.30	SMK (2.92mm) / N	128a	

Open / Short / Load...dc-2.0 GHz

Model Number	Frequency Range (GHz)	Connector Type	Maximum SWR	Maximum Phase Tracking (Short / Open) (±)	Average Input Power (W)	Page No.	
1591	dc-2.0	TNC (f)	1.05 - 1.35*	3° - 7° *	1	170	

(f) denotes female & (m) denotes male.

* Varies with Frequency.

- ♦ EXPRESS Shipment available via www.argosysales.com or 800-542-4457.
Note: Other models may also be available from Express delivery.

Terminations & Loads

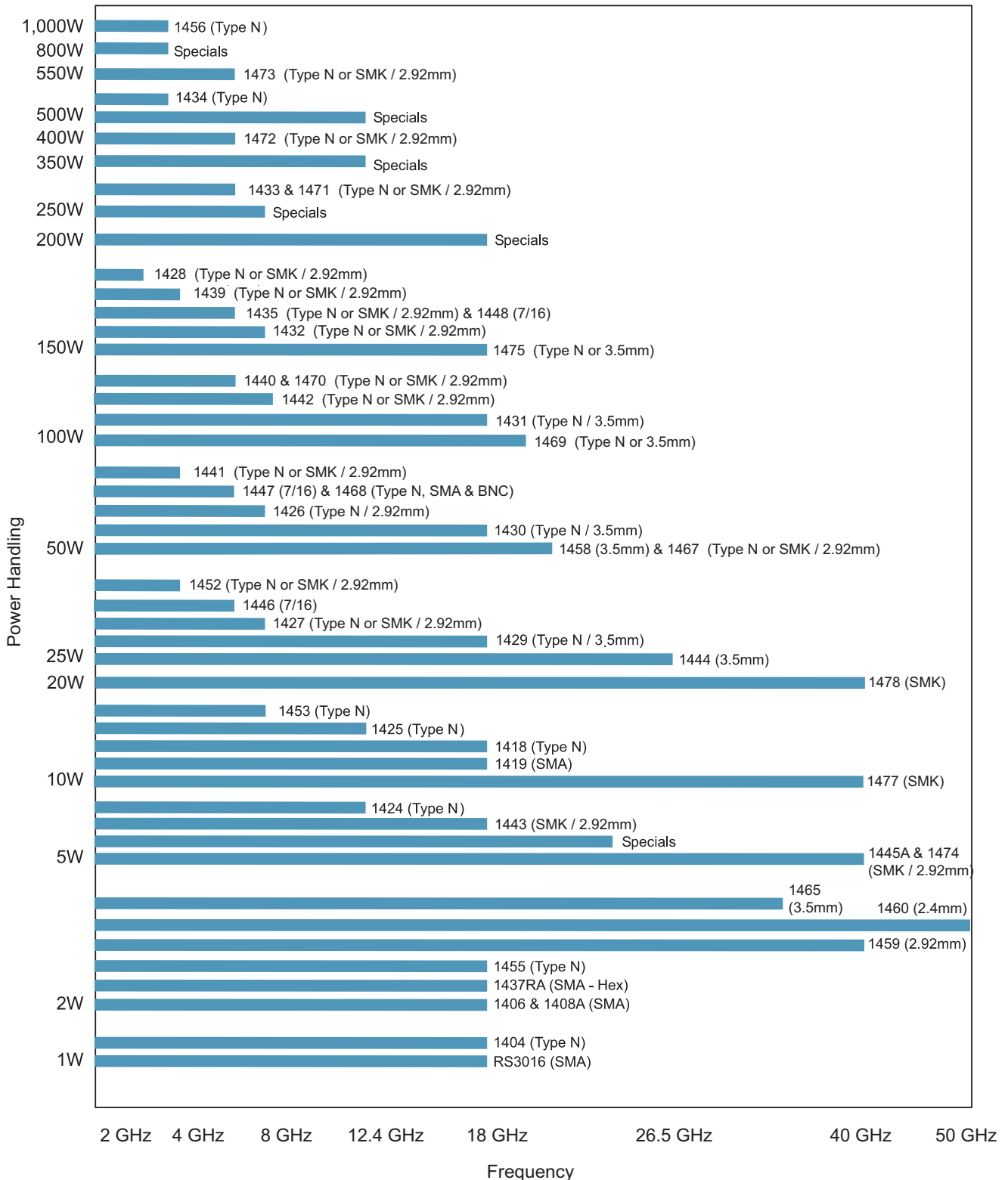

Termination Selection Guide: Power Handling / Frequency / Connector Type

Frequently Ask Questions about Coaxial Terminations...

What are the advantages of Aeroflex / Weinschel's terminations?

Most Aeroflex / Weinschel coaxial terminations feature a combination of advantages over other designs:

1. Most Aeroflex / Weinschel terminations feature injection molded dielectric for better center pin captivation and alignment. Injection molded dielectric also eliminates the need for the epoxy hole "stake" as seen in other designs. This epoxy hole in other designs is subject to RF leakage and movement when exposed to environmental extremes and prolonged use.
2. Aeroflex / Weinschel coaxial terminations have a proprietary resistor element fired at high temperatures (950°) for superior long term stability over temperature, power and time.
3. Aeroflex / Weinschel coaxial terminations have no solder contacts. They feature spring loaded plunger contacts to the resistor cards that provide expansion tolerant operation over wide temperature and power ranges.
4. Aeroflex / Weinschel terminations are made with high quality materials and machined to very close tolerances, the result is a design that stands up to severe environments and usage.
5. High power designs feature special high temperature support beads.

Can Aeroflex / Weinschel provide special terminations?

Yes. Aeroflex / Weinschel has produced many custom fixed attenuators and terminations. Specialized designs continue to be a significant part of Aeroflex / Weinschel's product offering. Special features may include:

1. Custom Connector Configurations
2. Matched Pairs or Sets
3. Lower VSWR
4. Conductive Cooled
5. Special Mounting & Environmental Conditions

How is the power rating calculated?

A termination will handle specified power at ambient temperatures as specified in the catalog. No special fan cooling is required. At higher temperatures the power rating

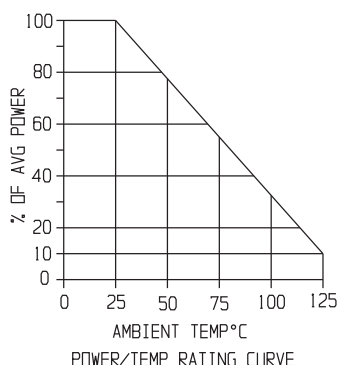

is calculated by using catalog specifications and a straight line graph. For instance the power rating of the Model 1430 attenuator is 100 watts at 25°C ambient and 10 watts at 125°C. Using linear graph paper, plot a straight line between these two points. This plot shows that the power rating at 75°C is approximately 56 Watts.

Can Aeroflex / Weinschel provide terminations for space applications?

Yes. Aeroflex / Weinschel terminations are being used on most major U.S. military and commercial communication satellites. Aeroflex / Weinschel Terminations can be screened to your specifications and testing requirements.

Aeroflex / Weinschel's use of precision connectors, injection molded captivation of connector contacts, internal pring/plunger contacts (no solder or contact fingers) and very precise and stable resistors result in a superior electrical and mechanical design that is ideally suited for space applications. Page 17 provides a list of Aeroflex / Weinschel's program experience and available testing programs for space qualified components.

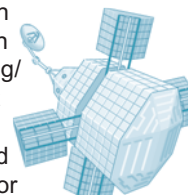

Does Aeroflex / Weinschel offer High Reliability Models?

Most Aeroflex / Weinschel Corporation Terminations & Loads can be supplied according to customer specified testing, environmental or military or government specification requirements.

What is Third-Order Intermodulation Distortion?

(IM3) Intermodulation distortion (IM) consists of the spurious signals which result from the mixing of nth order frequencies in the non-linear elements of a component. Third order intermodulation distortion is of particular interest because third order products typically represent the highest level distortion appearing close to the desired signal, and as such the highest level non-filterable distortion. Third order IM level (IM3) is tested by injecting two pure tones of equal magnitude (f1 and f2) into the component to be tested. The third order IM products will appear in the output spectrum at the frequencies 2f1-f2 and 2f2-f1. These products are characterized by defining their level (in dBc) relative to the fundamental output tones at either f1 or f2.

Does Aeroflex / Weinschel offer any of terminations with IM3 specified?

Yes, Aeroflex / Weinschel has recently introduced new as well as updated models specifically for applications requiring low intermodulation distortion. These models are available in 25, 50, 150 Watt varieties. Aeroflex / Weinschel can also modify or specify IM3 on several of its standard standard models such as 1418, 1426, 1427, 1428, 1429, 1430, 1431, 1432, 1433, 1435, 1439, & 1442. Refer to the specific data sheet for IM3 details.

Terminations & Loads



How do I select a termination for my application?

Termination applications exist in almost every phase of microwave technology from design and measurement to systems. Good terminations are an indispensable aid in making bench measurements on microwave components in the engineering laboratory, as those ports of a multiport microwave device which are not involved in the measurement should be terminated in their characteristic impedance in order to ensure an accurate measurement. Many microwave systems employ directional couplers which require terminations on at least one port, and most have various modes of operation or test where terminations are needed on certain terminals.

A matched termination of a generalized transmission line is ideally represented by an infinite length of that line having small, but non-zero loss per unit length so that all incident energy is absorbed and none is reflected. Although this type of matched load (termination) was actually used extensively during the early exploration of high frequencies where the wavelength was short enough for the method to be employed, more efficient and practical types of termination have been developed.

There are several ways in which a matched termination for a 50-ohm coaxial line may be realized. Some of these are shown below. Illustration A of the Figure shows a cross-section of coaxial line terminated in a lumped 50-ohm series resistor which is a short length of resistive film on a cylindrical ceramic substrate. Illustration B is similar to A except that the 50-ohm resistor is a film on a ceramic disc and appears in shunt with the open of the coaxial line.



More effective matched loads for very high frequencies are shown in illustration C and D.

The outer conductor in the design of illustration C is tapered in either an exponential or a tractrix curve from the region near the start of the resistive film on the inner conductor to the end of the resistor. The design of illustration D to these parameters, it is usually necessary to specify the shaped ceramic body extending from the inner conductor. The advantage of this design is that it dissipates more power. Aeroflex / Weinschel matched termination designs are similar to those shown in C.

A well-matched attenuator of at least 20 dB loss can also be utilized as a termination. This is particularly useful in high power applications. For example our new Model 1456 1,000 Watt termination is supplied with a second connector for power monitoring

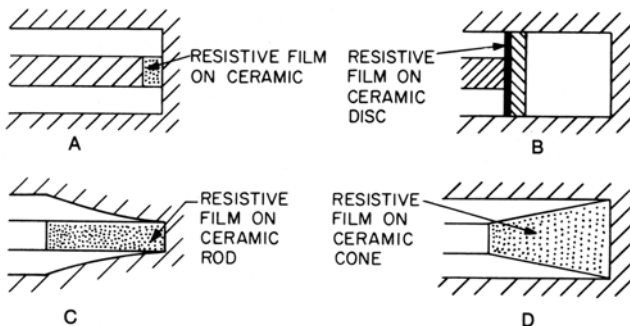

Model 1437RA Model RS3016 Subminiature, SMA Connector

dc to 6.0 GHz / 2 Watts
dc to 18.0 GHz / 1Watt



Features

- /// Subminiature Size and Lightweight
- /// Low Cost & SWR
- /// Cellular Applications: Optimized for use in the wireless communications bands.

Specifications

NOMINAL IMPEDANCE: 50 Ω

FREQUENCY RANGE: M/F1437RA: dc to 6.0 GHz
RS3016: dc to 18.0 GHz

POWER RATING:

Model 1437RA: 2.0 watts **average** @ 25°C ambient temperature, derated linearly to 0.5 watts @ 125°C. 250 watts **peak** maximum (5 μsec pulse width; 0.4% duty cycle).

Model RS3016: 1.0 watts **average** @ 25°C ambient temperature, derated linearly to 0 watts @ 125°C. 250 watts **peak** maximum (5 μsec pulse width; 0.2% duty cycle).

MAXIMUM SWR:			
Frequency Range (GHz)	F1437RA	M1437RA	RS3016
dc - 4	1.05	1.15	1.05
4 - 8 (6)	1.10	1.20	1.10
8 - 12.4	---	---	1.15
12.4 - 18	---	---	1.20

TEMPERATURE RANGE: -65°C to +125°C

CONNECTOR: Model 1437RA: SMA connectors - mate nondestructively with MIL-C-39012 connectors. Choice of male or female connector, prefix model number with M for male and F for female. **Model RS3016** available in SMA male only!

CONSTRUCTION: Passivated stainless steel connectors with gold plated beryllium copper contacts.

WEIGHT: M1437RA: 3.0 g (0.11 oz)
F1437RA: 4.0 g (0.14 oz)
RS3016: 2.3 g (0.08 oz)

PHYSICAL DIMENSIONS:

Model F1437RA:

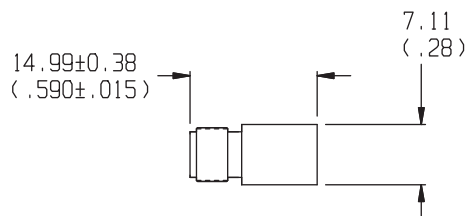

Model M1437RA:

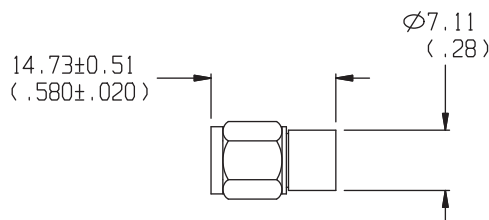

Model RS3016 (male only):

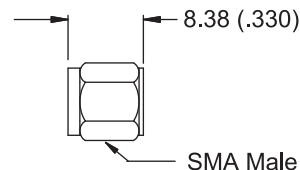

NOTE: All dimensions are given in mm (inches) and are maximum, unless otherwise specified.

Terminations & Loads



Model 1404N Precision Lab Standard N Connectors

dc to 18.0 GHz
1 Watt

RoHS



TEMPERATURE RANGE: -55°C to +85°C

TEST DATA: Swept data plots of SWR from 50 MHz to 18 GHz is available at additional cost.

CONNECTOR: Type N connector - mates nondestructively with MIL-C-39012 connector. Choice of male or female connector. When ordering, prefix model number with M for male and F for female.

CONSTRUCTION: Gold plated brass body; stainless steel connector; gold plated beryllium copper contacts.

WEIGHT: Net, 110 g (4 oz)

Features

- /// **Precision Connector** - Interface dimensions per MIL-STD-348 Test connector
- /// **Rugged Construction** - Numerically controlled machining is used to produce high quality uniform parts with controlled concentricity and surface finishes. The result is excellent SWR repeatability.

Specifications

NOMINAL IMPEDANCE: 50 Ω

FREQUENCY RANGE: dc to 18.0 GHz

POWER RATING: 1.0 watt **average** to 25 °C ambient temperature, derated linearly to 0.1 watts @ 125°C. 1 kilowatt **peak** maximum (5 μsec pulse width; 0.05 % duty cycle).

MAXIMUM SWR:

Model	SWR
F1404N	$\leq 1.04 + 0.0023f$ (GHz)
M1404N	$\leq 1.02 + 0.0033f$ (GHz)

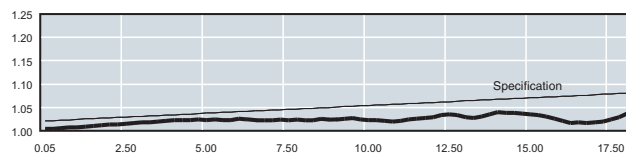

Typical M1404 SWR Performance

PHYSICAL DIMENSIONS:

MODEL F1404N:

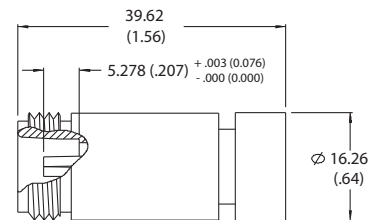

MODEL M1404N:

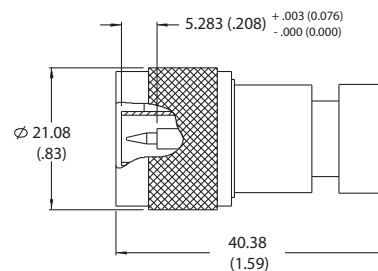

NOTE: All dimensions are given in mm (inches) and are maximum, unless otherwise specified.

Models 1406A & 1408

Subminiature, Ruggedized SMA Connectors

dc to 18.0 GHz

2 Watts



RoHS

TEMPERATURE RANGE: -54°C to +100°C

TEST DATA: Swept data plots of SWR from 50 MHz to 18 GHz is available at additional cost.

CONNECTOR: SMA connector per MIL-STD-348 interface dimensions - mate nondestructively with MIL-C-39012 connector. Choice of male or female connector. When ordering, prefix model number with M for male and F for female.

CONSTRUCTION: Gold plated beryllium copper contacts with passivated stainless steel.

WEIGHT: Male Connector: 2.8 g (0.1 oz)
Female Connector: 1.4 g (0.05 oz)

PHYSICAL DIMENSIONS:

M1406 / M1408:

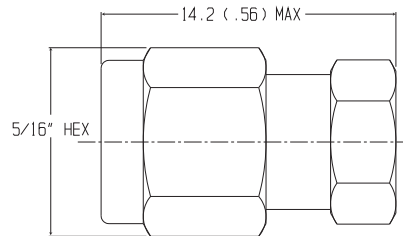

F1406 / F1408:

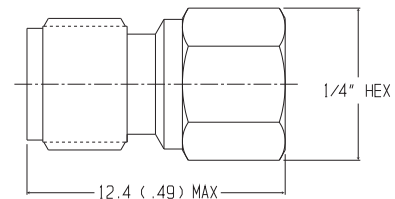

NOTE: All dimensions are given in mm (inches) and are maximum, unless otherwise specified.

Features

Models 1406A & 1408 are general purpose subminiature terminations that operate in the frequency range of dc to 18 GHz but are usable to 26.5 GHz.

- /// **Low SWR** - Model 1406A has low VSWR across its operating range (typical SWR is less than specified). The Model 1408 has ultra-low SWR to 18 GHz (usable to 26.5 GHz).
- /// **Subminiature Size and Lightweight** - All models are approximately 0.5 inches long, and weigh less than 3 grams with male connector and 1.5 grams with female connector.
- /// **Rugged Construction.**

Specifications

NOMINAL IMPEDANCE: 50 Ω

FREQUENCY RANGE: dc to 18.0 GHz

POWER RATING: 2 Watts average @ 25 C ambient temperature derated linearly to 0.2 watt @ 100°C. 500 watts peak (5 μsec pulse width; 0.2% duty cycle).

MAXIMUM SWR:

Model	SWR
1406A	1.05 + 0.009f (GHz)
1408	1.04 + 0.006f (GHz)

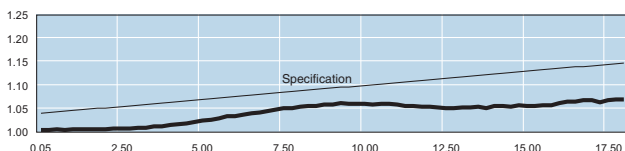

Typical M1408 SWR Performance

Terminations & Loads



Model 1455 General Purpose, N Connectors

dc to 18.0 GHz
2 Watt



Features

- /// **Low Cost Type N Connector** - Interface dimensions per MIL-STD-348 Test connector.
- /// **Rugged Construction** - Numerically controlled machining is used to produce high quality uniform parts with controlled concentricity and surface finishes. The result is excellent SWR repeatability.

Specifications

NOMINAL IMPEDANCE: 50 Ω

FREQUENCY RANGE: dc to 18.0 GHz

MAXIMUM SWR:		
Frequency Range (GHz)	1455-3	1455-4
dc - 8	1.20	1.20
8 - 12.4	1.25	1.20
12.4 - 18	1.30	1.25

POWER RATING: 2 watts **average** to 25°C ambient temperature, derated linearly to 1 watts @ 125°C. 1 kilowatt **peak** (5 μsec pulse width; 0.5 % duty cycle)

TEMPERATURE RANGE: -65°C to +125°C

CONNECTOR: Type N connector per MIL-STD-348 interface dimensions - mate nondestructively with MIL-C-39012 connector. Choice of male or female connector. Order as follows:

Model	Connector Type
1455-4	Type N Male
1455-3	Type N Female
1455-4C	Type N Male with chain
1455-3C	Type N Female with chain

CONSTRUCTION: Nickel plated brass connector; gold plated beryllium copper contacts, stainless steel bead chains.

WEIGHT: 110 g (4 oz) maximum

PHYSICAL DIMENSIONS:

Model 1455-3:

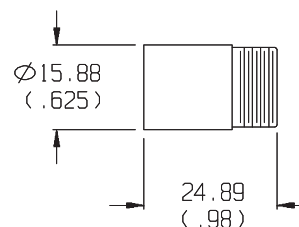

Model 1455-4:

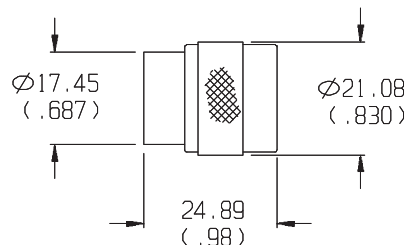

Model 1455-3C:

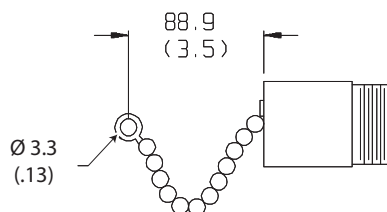

Model 1455-4C:

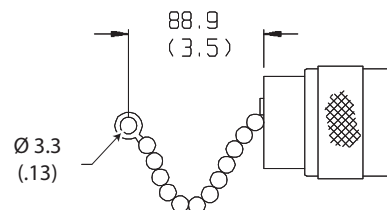

NOTE: All dimensions are given in mm (inches) and are maximum, unless otherwise specified.

Model 1465 Precision, 3.5mm Connectors

dc to 32.0 GHz
2 Watt



Features

- /// High Performance - Precision Lab Grade
- /// Subminiature Size and Lightweight - All models weigh 7 grams with male connector
- /// Low SWR Design Option
- /// Rugged Construction

Specifications

NOMINAL IMPEDANCE: 50 Ω

FREQUENCY RANGE: dc to 32.0 GHz

POWER RATING: 2.0 watt **average** @ 25°C ambient temperature, derated linearly to 0.2 watts @ 100°C. 500 watts **peak** maximum (5 μsec pulse width; 0.2% duty cycle).

MAXIMUM SWR:

Frequency Range (GHz)	F1465 M1465	F1465A M1465A
dc - 18	1.08	1.06
18 - 26.5	1.10	1.08
26.5 - 32	1.15	1.10

TEMPERATURE RANGE: -50°C to +100°C

STORAGE TEMPERATURE: -50°C to +125°C

TEST DATA: Swept data plots of SWR from 50 MHz to 32 GHz is available at additional cost.

CONNECTOR: Male or Female 3.5mm connector - mate nondestructively with SMA, SMK, 2.92mm, and other 3.5mm connectors. Choice of male or female connector. When ordering, prefix model number with M for male and F for female.

PIN RECESSION: 0.003 maximum (male and female connectors)

WEIGHT: 7.0 g (0.25 oz) maximum

PHYSICAL DIMENSIONS:

Model M1465/M1465A:

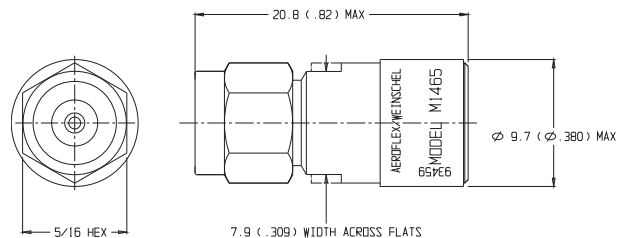

Model F1465/F1465A:

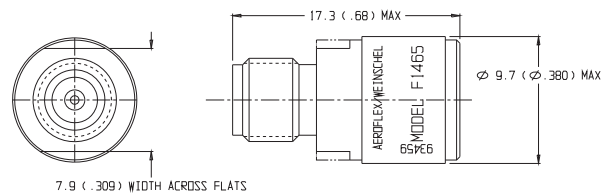

NOTE: All dimensions are given in mm (inches) and are maximum, unless otherwise specified.

Terminations & Loads



Model 1459 Precision, SMK Connectors

dc to 40.0 GHz
2 Watts

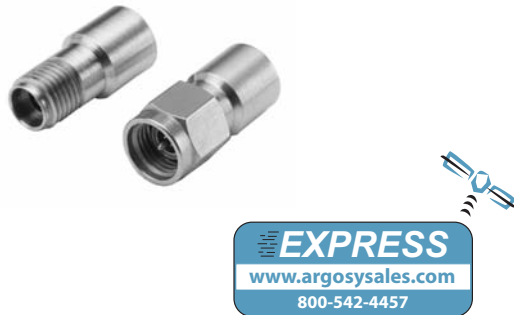

PHYSICAL DIMENSIONS:

Model M1459/M1459A:

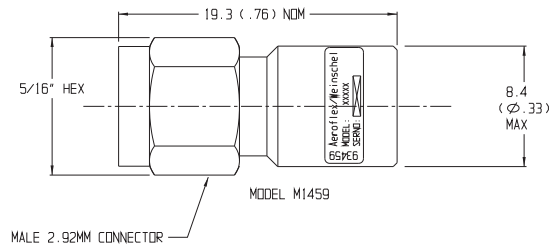

Model F1459/F1459A:

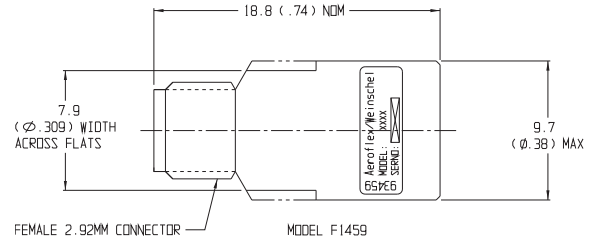

NOTE: All dimensions are given in mm (inches) and are maximum, unless otherwise specified.

Features

- /// High Performance - Precision Lab Grade
- /// Subminiature Size and Lightweight - All models weigh 6 grams with male connector
- /// Low SWR Design Option
- /// Rugged Construction

Specifications

NOMINAL IMPEDANCE: 50 Ω

FREQUENCY RANGE: dc to 40.0 GHz

POWER RATING: 2.0 watt **average** @ 25°C ambient temperature, derated linearly to 0.2 watts @ 100°C. 500 watts **peak** maximum (5 μsec pulse width; 0.2% duty cycle).

MAXIMUM SWR:

Frequency Range (GHz)	F1459 M1459	F1459A	M1459A
dc - 18	1.15	1.10	1.10
18 - 40	1.25	1.18	1.15

TEMPERATURE RANGE: -50°C to +100°C

TEST DATA: Swept data plots of SWR from 50 MHz to 40 GHz is available at additional cost.

CONNECTOR: SMK (2.92mm) connector compatible with SMA, 3.5mm and SMK connector. Choice of male or female connector. When ordering, prefix model number with M for male and F for female.

WEIGHT: 6.0 g (0.17 oz) maximum

S22 REVERSE REFLECTION

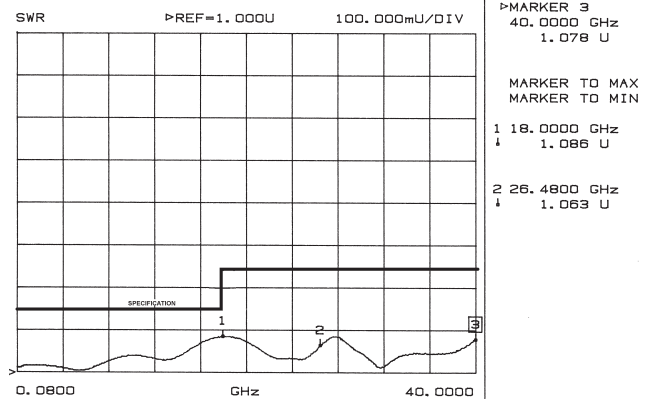

Typical M1459 SWR Performance

Model 1460 Precision, 2.4mm Connectors

dc to 50.0 GHz
2 Watt



Features

- /// High Performance - Precision Lab Grade
- /// Subminiature Size and Lightweight - All models weigh less than 6 grams with male connector
- /// Low SWR Design Option
- /// Rugged Construction

Specifications

NOMINAL IMPEDANCE: 50 Ω

FREQUENCY RANGE: dc to 50.0 GHz

POWER RATING: 2.0 watt **average** @ 25°C ambient temperature, derated linearly to 0.2 watts @ 100°C. 500 watts **peak** maximum (5 μsec pulse width; 0.2% duty cycle).

MAXIMUM SWR:

Frequency Range (GHz)	F1460 M1460	M1460A F1460A
dc - 20	1.10	1.10
20 - 50	1.22	1.15

TEMPERATURE RANGE: -50°C to +100°C

TEST DATA: SWR Testing performed across the frequency band. Test data is available at additional cost.

CONNECTOR: 2.4mm connector mates nondestructively with other 2.4mm connectors. Choice of male or female connector. When ordering, prefix model number with M for male and F for female.

TEST DATA: Swept data plots of SWR from 50 MHz to 32 GHz.

WEIGHT: 6.0 g (0.16 oz) maximum

PHYSICAL DIMENSIONS:

Model M1460/M1460A:

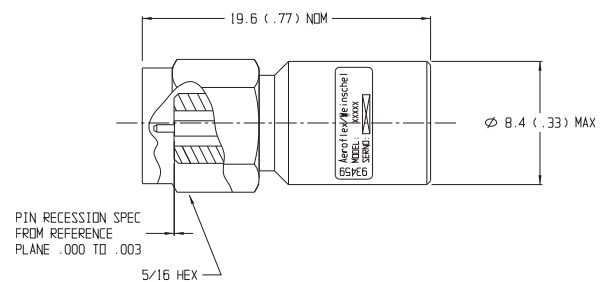

Model F1460/F1460A:

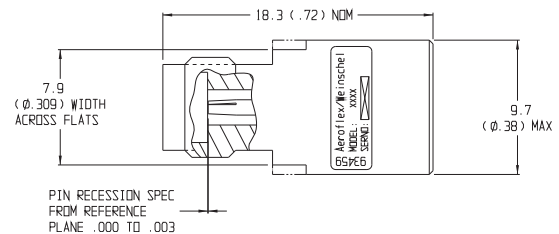

NOTE: All dimensions are given in mm (inches) and are maximum, unless otherwise specified.

Terminations & Loads



Model 1424 N Connectors

dc to 12.4 GHz
5 Watt



EXPRESS
www.argosysales.com
800-542-4457

TEST DATA: Swept data plots of SWR from 50 MHz to 12.4 GHz.

CONNECTOR: Type N connector per MIL-STD-348 interface dimensions - mate nondestructively with MIL-C-39012 connector.

Connector Options	Type/Description
3	Type N, Female
4	Type N, Male

CONSTRUCTION: Stainless steel connector; gold plated beryllium copper contacts

WEIGHT: Net 60 g (2 oz)

PHYSICAL DIMENSIONS:

Features

- /// **Quality Connectors** - Choice of male or female N connector that mate nondestructively with connector manufactured in accordance with MIL-C-39012.
- /// **Rugged Construction.**

Specifications

NOMINAL IMPEDANCE: 50 Ω

FREQUENCY RANGE: dc to 12.4 GHz

MAXIMUM SWR:

Frequency (GHz)	SWR
dc - 2	1.03
2 - 4	1.05
4 - 8	1.15
8 - 12.4	1.30

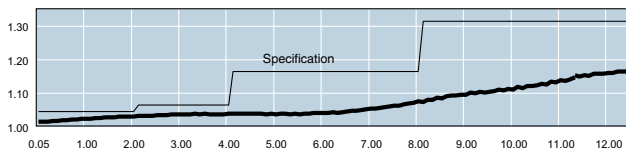

Typical 1424-3 SWR Performance

POWER RATING: 5 watts **average** @ 25°C ambient temperature, derated linearly to 0 watts @ 125°C. 5 kilowatts **peak** (5 μsec pulse width; 0.05 % duty cycle)

TEMPERATURE RANGE: -55°C to +125°C

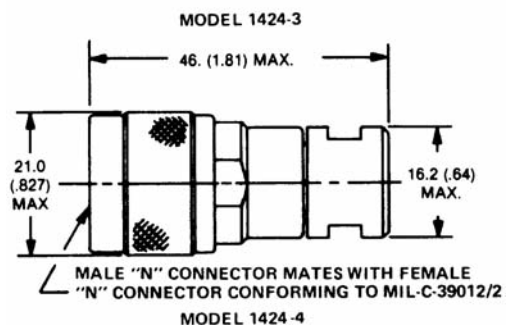
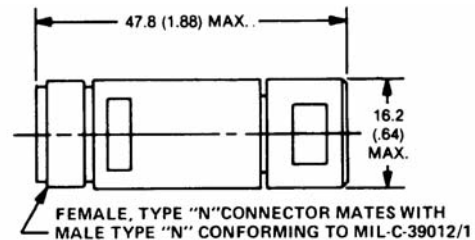

NOTE: All dimensions are given in mm (inches) and are maximum, unless otherwise specified.

Model 1443A Subminiature, SMA Connectors

dc to 18.0 GHz
5 Watts

 **RoHS**

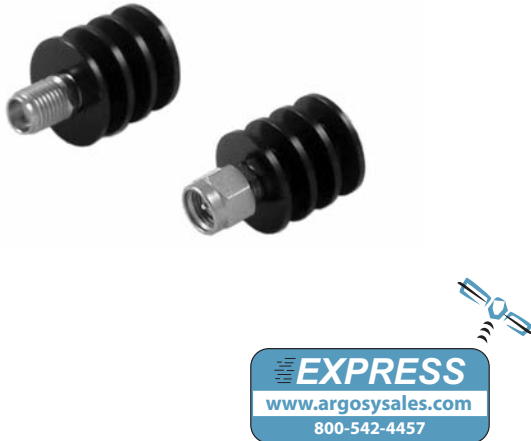

Features

- /// **Compact Construction** - Lowest size/power ratio.
- /// **Precision Injection Molded Connector.**
- /// **Low SWR.**

Specifications

NOMINAL IMPEDANCE: 50 Ω

FREQUENCY RANGE: dc to 18.0 GHz

MAXIMUM SWR:

Frequency (GHz)	SWR
dc - 18	1.15

POWER RATING: 5 watts **average** (mounted horizontally assuming unobstructed air flow and natural convection around unit) to 25°C ambient temperature, derated linearly to 0.5 watts @ 100°C. 500 watts **peak** (5 μsec pulse width; 0.5% duty cycle).

TEMPERATURE RANGE: -55°C to +100°C

TEST DATA: Swept data plots of SWR from 50 MHz to 18 GHz is available at additional cost.

CONNECTOR: SMA connector per MIL-STD-348 interface dimensions - mate nondestructively with SMK, 3.5mm, 2.92mm and SMA connectors per MIL-C-39012 .

Choice of male (-2) or female (-1) connector.

CONSTRUCTION: Black, finned aluminum body, stainless steel connector; gold plated beryllium copper contacts.

WEIGHT: 10 g (0.35 oz)

PHYSICAL DIMENSIONS:

Model 1443A-1:

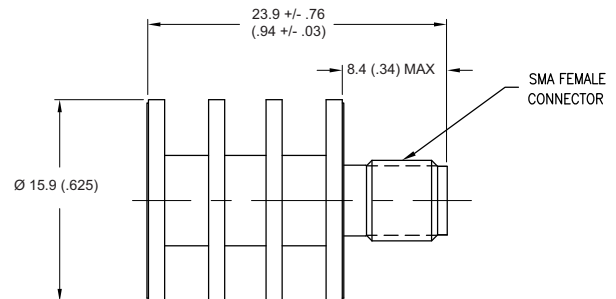

Model 1443A-2:

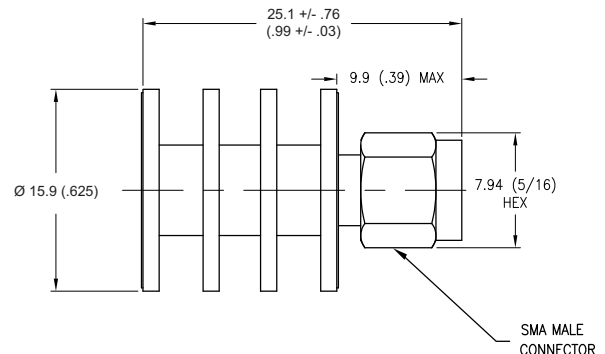

NOTE: All dimensions are given in mm (inches) and are maximum, unless otherwise specified.

Terminations & Loads



Model 1445A SMK Connectors

dc to 40.0 GHz
5 Watts



TEMPERATURE RANGE: -55°C to +125°C

TEST DATA: Swept data plots of SWR from 50 MHz to 40 GHz is available at additional cost.

CONNECTOR: 2.92mm connector mate nondestructively with SMA per MIL-C-39012, SMK, 3.5mm and other 2.92mm connector. Choice of male (-2) or female connector (-1).

CONSTRUCTION: Black, finned aluminum body, gold plated beryllium copper contacts.

WEIGHT: 200 g (7 oz)

PHYSICAL DIMENSIONS:

Features

- /// **Compact Construction** - Lowest size/power ratio.
- /// **Precision Injection Molded Connector.**

Specifications

NOMINAL IMPEDANCE: 50 Ω

FREQUENCY RANGE: dc to 40.0 GHz

MAXIMUM SWR:	
Frequency (GHz)	SWR
dc - 18	1.20
18 - 40	1.35

POWER RATING: 5 watts **average (mounted horizontally)** to 25°C ambient temperature, derated linearly to 0.5 watts @ 125°C. 200 watts **peak** (5 μsec pulse width; 1.25% duty cycle).

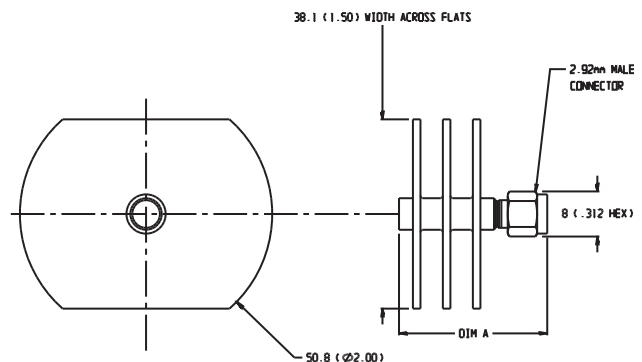

Model #	DIM A	Connector Type
1445A-1	33.8 (1.33)	2.92mm female
1445A-2	37.8 (1.49)	2.92mm male

NOTE: All dimensions are given in mm (inches) and are maximum, unless otherwise specified.

Model 1419

dc to 18.0 GHz

Medium Power, Ruggedized SMA Connectors

10 Watts

RoHS



Features

- /// **Miniature Size and Lightweight** - All models are approximately 1.6 inches long, and weigh less than 14 grams with male connector.
- /// **Quality Injection Molded Connector.**

Specifications

NOMINAL IMPEDANCE: 50 Ω

FREQUENCY RANGE: dc to 18.0 GHz

MAXIMUM SWR:

Frequency (GHz)	SWR
dc - 8	1.20
8 - 12.4	1.30
12.4 - 18	1.35

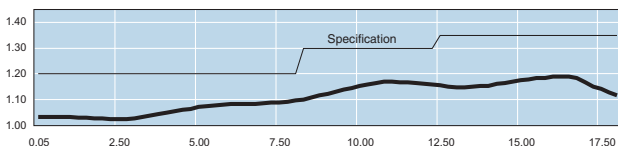

Typical M1419 SWR Performance

POWER RATING: 10 watts **average** (mounted horizontally) @ 25°C ambient temperature, derated linearly to 0 watts @ 125°C. 1 kilowatt **peak** (5 μsec pulse width; 0.5% duty cycle).

TEMPERATURE RANGE: -55°C to +125°C

TEST DATA: Swept data plots of SWR from 50 MHz to 18 GHz.

CONNECTOR: SMA connector per MIL-STD-348 interface dimensions - mate nondestructively with MIL-C-39012 connector. Choice of male or female connector. When ordering, prefix model number with M for male and F for female.

CONSTRUCTION: Black, finned aluminum body, stainless steel connector; gold plated beryllium copper contacts.

WEIGHT: 14 g (0.49 oz)

PHYSICAL DIMENSIONS:

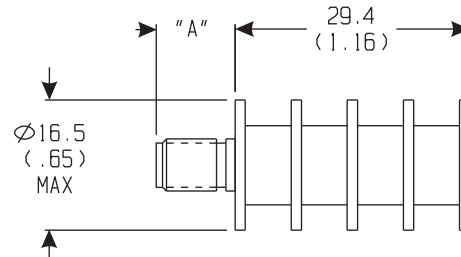

Model #	DIM A	Connector Type
M1419	11.2 (0.44)	SMA male
F1419	9.4 (0.37)	SMA female

NOTE: All dimensions are given in mm (inches) and are maximum, unless otherwise specified.

Terminations & Loads



Model 1453 Medium Power, N Connectors

dc to 8.5 GHz
10 Watts

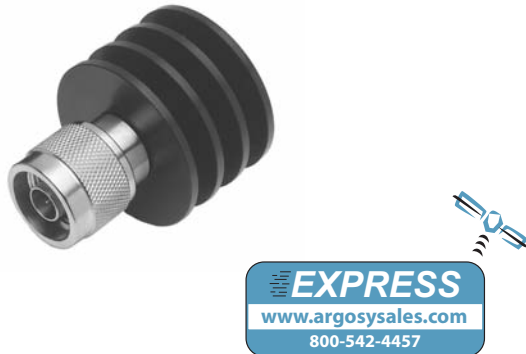

Features

- /// Optimized for Wireless OEM and Test Applications.
- /// Designed to meet environmental requirements of MIL-D-39030.
- /// Quality Injection Molded Connector.

Specifications

NOMINAL IMPEDANCE: 50 Ω

FREQUENCY RANGE: dc to 8.5 GHz

MAXIMUM SWR:	
Frequency (GHz)	SWR
dc - 4	1.15
4 - 8.5	1.25

POWER RATING: 10 watts **average (mounted horizontally)** @ 25°C ambient temperature, derated linearly to 1 watt @ 125°C. 1 kilowatt **peak** (5 μsec pulse width; 0.5% duty cycle).

TEMPERATURE RANGE: -55°C to +125°C

TEST DATA: Swept data plots of SWR from 50 MHz to 8.5 GHz.

CONNECTOR: Type N connector per MIL-STD-348 interface dimensions - mate nondestructively with MIL-C-39012 connector. Choice of male (-4) or female connector (-3).

CONSTRUCTION: Black, finned aluminum body, stainless steel connector; gold plated beryllium copper contacts.

WEIGHT: 85 g (3 oz)

PHYSICAL DIMENSIONS:

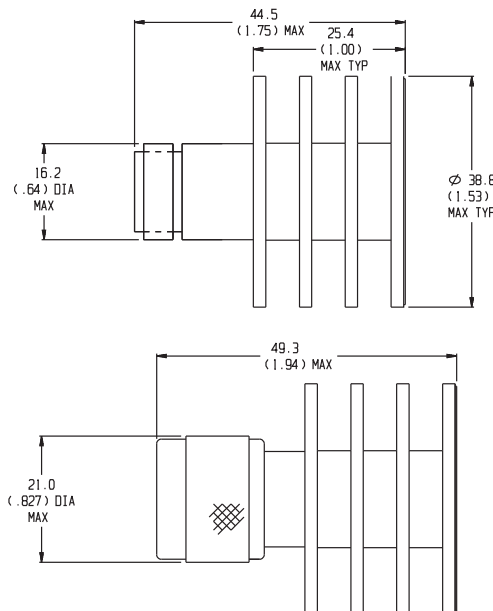

NOTE: All dimensions are given in mm (inches) and are maximum, unless otherwise specified.

Model 1425 Medium Power, N Connectors

dc to 12.4 GHz
10 Watts

RoHS



Features

- /// **Quality Connectors** - Choice of male or female N connector that mate nondestructively with connector manufactured in accordance with MIL-C-39012.
- /// **Rugged Construction.**

Specifications

NOMINAL IMPEDANCE: 50 Ω

FREQUENCY RANGE: dc to 12.4 GHz

MAXIMUM SWR:

Frequency (GHz)	SWR
dc - 2	1.03
2 - 4	1.05
4 - 8	1.15
8 - 12.4	1.30

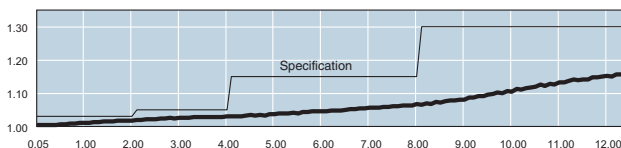

Typical 1425-4 SWR Performance

POWER RATING: 10 watts **average (mounted horizontally)** @ 25°C ambient temperature, derated linearly to 0 watts @ 125°C. 1 kilowatt **peak** (5 μsec pulse width; 0.5% duty cycle).

TEMPERATURE RANGE: -55°C to +125°C

TEST DATA: Swept data plots of SWR from 50 MHz to 12.4 GHz is available at additional cost.

CONNECTOR: Type N connector per MIL-STD-348 interface dimensions - mate nondestructively with MIL-C-39012 connector.

Connector Options	Type/Description
3	Type N, Female
4	Type N, Male

CONSTRUCTION: Black, finned aluminum body, stainless steel connector; gold plated beryllium copper contacts

WEIGHT: Net 110 g (4 oz)

PHYSICAL DIMENSIONS:

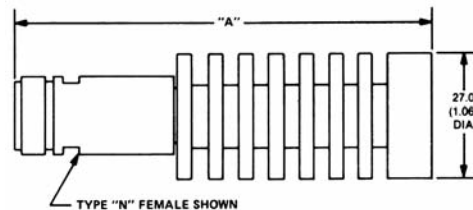

Model #	DIM A	Connector Type
1425-4	84.58 (3.33)	N, male
1425-3	86.36 (3.40)	N, female

NOTE: All dimensions are given in mm (inches) and are maximum, unless otherwise specified.

Terminations & Loads



Model 1418 Medium Power, N Connectors

dc to 18.0 GHz
10 Watts



TEMPERATURE RANGE: -55°C to +125°C

TEST DATA: Swept data plots of SWR from 50 MHz to 18 GHz.

CONNECTOR: Type N connector per MIL-STD-348 interface dimensions - mate nondestructively with MIL-C-39012 connector. Choice of male or female connector. When ordering, prefix model number with M for male and F for female.

CONSTRUCTION: Black, finned aluminum body, stainless steel connector; gold plated beryllium copper contacts.

WEIGHT: 90 g (3 oz)

PHYSICAL DIMENSIONS:

Features

- /// Optimized for Wireless OEM and Test Applications.
- /// Designed to meet environmental requirements of MIL-D-39030.
- /// Quality Injection Molded Connector.

Specifications

NOMINAL IMPEDANCE: 50 Ω

FREQUENCY RANGE: dc to 18.0 GHz

MAXIMUM SWR:

Frequency (GHz)	SWR
dc - 4	1.15
4 - 8	1.20
8 - 12.4	1.25
12.4 - 18	1.40

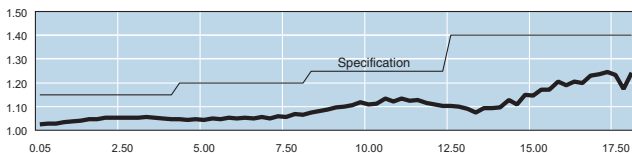

Typical M1418 SWR Performance

POWER RATING: 10 watts **average (mounted horizontally)** @ 25°C ambient temperature, derated linearly to 0 watt @ 125°C. 1 kilowatt **peak** (5 μsec pulse width; 0.5% duty cycle).

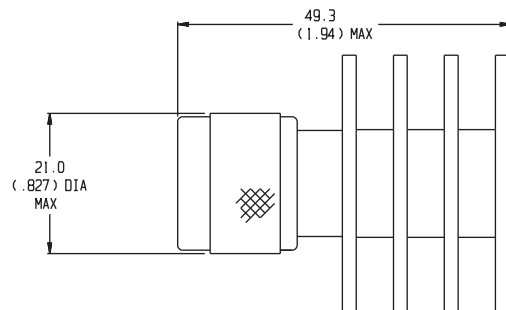
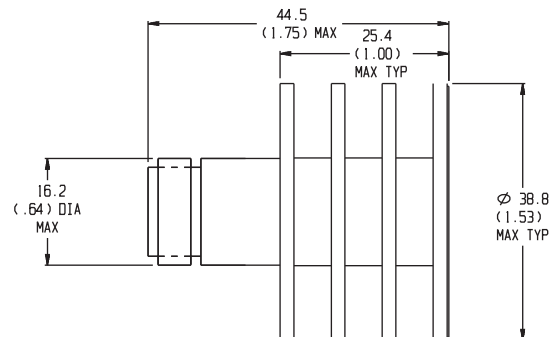

NOTE: All dimensions are given in mm (inches) and are maximum, unless otherwise specified.

Terminations & Loads



Model 1477 SMK Connectors

dc to 40.0 GHz
10 Watts



RoHS



Features

- /// **Compact Construction** - Lowest size/power ratio.
- /// **Precision Injection Molded Connector.**

Specifications

NOMINAL IMPEDANCE: 50 Ω

FREQUENCY RANGE: dc to 40.0 GHz

MAXIMUM SWR:	
Frequency (GHz)	SWR
dc - 18	1.20
18 - 40	1.35

POWER RATING: 10 watts **average** (mounted horizontally) to 25°C ambient temperature, derated linearly to 0.5 watts @ 125°C. 200 watts **peak** (5 μ sec pulse width; 1.25% duty cycle).

TEMPERATURE RANGE: -55°C to +125°C

TEST DATA: Swept data plots of SWR from 50 MHz to 40 GHz is available at additional cost.

CONNECTOR: SMK (2.92mm) connector mate non-destructively with SMA per MIL-C-39012, 3.5mm and other 2.92mm connectors. Choice of male (-2) or female connector (-1).

CONSTRUCTION: Black, finned aluminum body, gold plated beryllium copper contacts.

WEIGHT: 200 g (7 oz)

PHYSICAL DIMENSIONS:

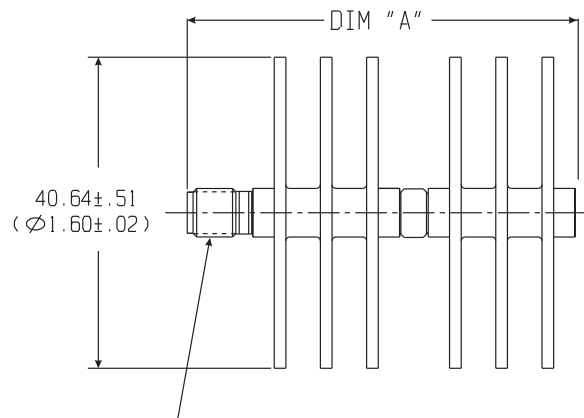

Model #	DIM A	Connector Type
1477-1		SMK female
1477-2		SMK male

NOTE: All dimensions are given in mm (inches) and are maximum, unless otherwise specified.

Model 1478 SMK Connectors

dc to 40.0 GHz
20 Watts



RoHS



Features

- /// **Compact Construction** - Lowest size/power ratio.
- /// **Precision Injection Molded Connector.**

Specifications

NOMINAL IMPEDANCE: 50 Ω

FREQUENCY RANGE: dc to 40.0 GHz

MAXIMUM SWR:	
Frequency (GHz)	SWR
dc - 18	1.20
18 - 40	1.35

POWER RATING (mounted horizontally): 20 watts **average (unidirectional)** to 25°C ambient temperature, derated linearly to 2 Watts @ 125°C. 200 watts **peak** (5 μsec pulse width; 5% duty cycle).

TEMPERATURE RANGE: -55°C to +125°C

TEST DATA: Swept data plots of SWR from 50 MHz to 40 GHz is available at additional cost.

CONNECTOR: 2.92mm connector mate nondestructively with SMA per MIL-C-39012, SMK, 3.5mm and other 2.92mm connector. Choice of male (-2) or female connector (-1).

CONSTRUCTION: Black, finned aluminum body, gold plated beryllium copper contacts.

WEIGHT: 200 g (7 oz)

PHYSICAL DIMENSIONS:

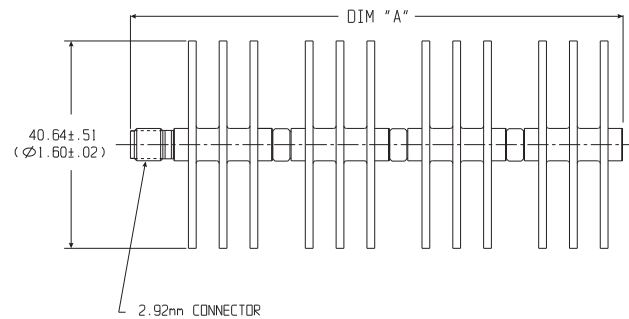

Model #	DIM A	Connector Type
1478-1		SMK female
1478-2		SMK male

NOTE: All dimensions are given in mm (inches) and are maximum, unless otherwise specified.

Model 1452 Medium Power, N or SMK Connectors Convection Cooled

dc to 4.0 GHz
25 Watts

 **RoHS**



TEST DATA: Swept data plots of SWR from 50 MHz to 4 GHz is available at additional cost.

CONNECTOR: Type N or SMK (2.92mm) connectors mate nondestructively with MIL-C-39012 connector.

Connector Options	Type/Description
1	SMK, Female
2	SMK, Male
3	Type N, Female
4	Type N, Male

CONSTRUCTION: Black, finned aluminum body, stainless steel connector; gold plated beryllium copper contacts.

WEIGHT: 150 g (5.2 oz)

PHYSICAL DIMENSIONS:

Features

- /// Optimized for Wireless OEM and Test Applications.
- /// Designed to meet environmental requirements of MIL-D-39030.
- /// Quality Injection Molded Connector.
- /// 5 Kilowatts Peak Power.

Specifications

NOMINAL IMPEDANCE: 50 Ω

FREQUENCY RANGE: dc to 4.0 GHz

MAXIMUM SWR*:

Frequency (GHz)	SWR
dc - 2	1.10
2 - 4	1.20

POWER RATING: 25 watts average (mounted horizontally assuming unobstructed air flow and natural convection around unit) @ 25°C ambient temperature, derated linearly to 2.5 watts @ 125°C. 5 kilowatts peak (5 μsec pulse width; 0.25% duty cycle).

TEMPERATURE RANGE: -55°C to +125°C

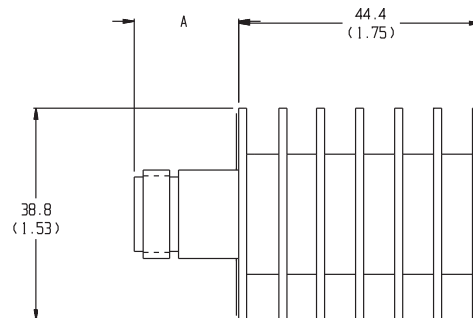

Model #	DIM A	Connector Type
1452-1	12.7 (0.50)	2.92mm female
1452-2	14.0 (0.55)	2.92mm male
1452-3	15.0 (0.59)	N female
1452-4	22.9 (0.90)	N male

NOTE: All dimensions are given in mm (inches) and are maximum, unless otherwise specified.

Terminations & Loads



Model 1446 Medium Power, 7/16 Connectors Low Intermodulation Design

25 Watts
dc to 6.0 GHz



PHYSICAL DIMENSIONS:

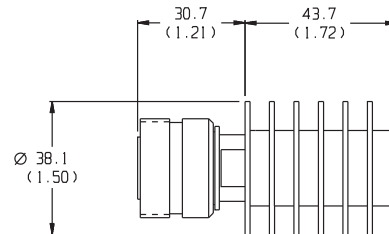

MODEL NO. 1446-1 FEMALE

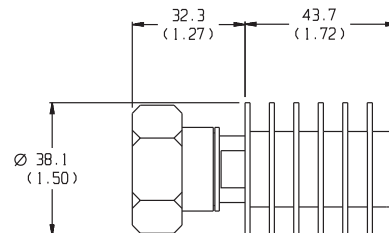

MODEL NO. 1446-2 MALE

NOTE: All dimensions are given in mm (inches) and tolerances are X.X+0.8 (0.3) unless otherwise specified.

Features

- /// Optimized for Wireless OEM and Test Applications.
- /// Designed to meet environmental requirements of MIL-D-39030.
- /// Custom Designs Available.

Specifications

NOMINAL IMPEDANCE: 50 Ω

FREQUENCY RANGE: dc to 6.0 GHz

MAXIMUM SWR:

Frequency (GHz)	SWR
dc - 6	1.20

POWER RATING: (mounted horizontally assuming unobstructed air flow and natural convection around unit): 25 watts **average** @ 25°C ambient temperature, derated linearly to 2.5 watts @ 125°C. 5 kilowatts **peak** (5 μsec pulse width; 0.25% duty cycle).

INTERMODULATION: IM3 (Reflected) = -100 dBc with two +41 dBm Input Tones @ 869 MHz and 891 MHz.

TEMPERATURE RANGE: -55°C to 125°C.

TEST DATA: Swept data plots of SWR from 50 MHz to 18 GHz is available at additional cost.

CONNECTOR: 7/16 connector that conforms to DIN 47 223, IEC 1694, VG 95250, CECC 22190. Choice of 7/16 male(-2) of 7/16 female (-1) connector

CONSTRUCTION: Black, finned aluminum body, silver plated brass connector.

WEIGHT: Net 216 g (7.6 oz) maximum

Model 1427 Medium Power, N or SMK Connectors Convection Cooled

dc to 10.0 GHz
25 Watts



Features

- /// Designed to meet environmental requirements of Quality Injection Molded Connector.
- /// Low Intermodulation Option
- /// 5 Kilowatts Peak Power

Specifications

NOMINAL IMPEDANCE: 50 Ω

FREQUENCY RANGE: dc to 10.0 GHz

MAXIMUM SWR:

Frequency (GHz)	SWR
dc - 4	1.10
4 - 8	1.15
8 - 10	1.30

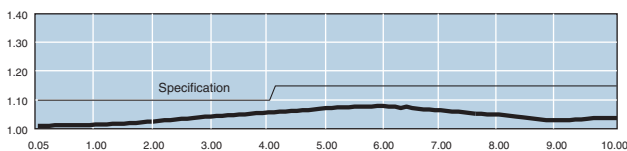

Typical M1427 SWR Performance

POWER RATING: 25 watts **average (mounted horizontally)** @ 25°C ambient temperature, derated linearly to 2.5 watts @ 125°C. 5 kilowatts **peak** (5 μsec pulse width; 0.25% duty cycle).

TEMPERATURE RANGE: -55°C to +125°C

INTERMODULATION (Model 1427-X-LIM Only): IM3 (Reflected) = -100 dBc with two input signals @ 869 MHz and 891 MHz with an average power of +41 dBm each.

TEST DATA: Swept data plots of SWR from 50 MHz to 10 GHz is available at additional cost.

CONNECTOR: Type N or SMK (2.92mm) connectors mate nondestructively with MIL-C-39012 connector.

Connector Options	Type/Description
1	SMK, Female
2	SMK, Male
3	Type N, Female
4	Type N, Male

CONSTRUCTION: Black, finned aluminum body, stainless steel connector; gold plated beryllium copper contacts.

WEIGHT: 150 g (5.2 oz)

PHYSICAL DIMENSIONS:

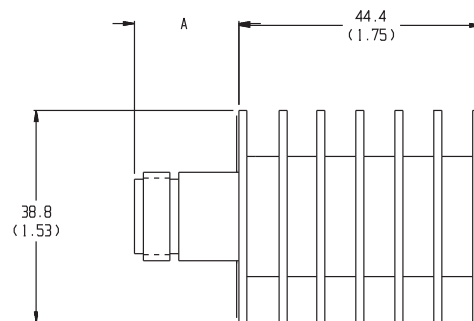

Model #	DIM A	Connector Type
1427-1	12.7 (0.50)	2.92mm female
1427-2	14.0 (0.55)	2.92mm male
1427-3	15.0 (0.59)	N female
1427-4	22.9 (0.90)	N male

NOTE: All dimensions are given in mm (inches) and are maximum, unless otherwise specified.

MODEL NUMBER DESCRIPTION:

Example:

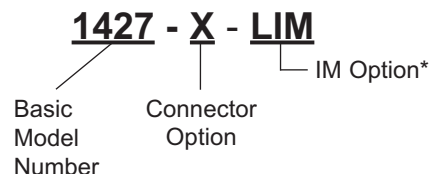

* Add -LIM to entire model number for Low Intermodulation option. Option not available through Express.

Terminations & Loads



Model 1429 Medium Power, N & 3.5mm Connectors Convection Cooled

dc to 18.0 GHz
25 Watts



Features

- /// Designed to meet environmental requirements of MIL-D-39030.
- /// Rugged injection molded connector.
- /// Low Intermodulation Option.
- /// 1 Kilowatt Peak Power

Specifications

NOMINAL IMPEDANCE: 50 Ω

FREQUENCY RANGE: dc to 18.0 GHz

MAXIMUM SWR:	
Frequency (GHz)	SWR
dc - 18	1.20

POWER RATING: 25 watts average (mounted horizontally assuming unobstructed air flow and natural convection around unit) @ 25°C ambient temperature, derated linearly to 2.5 watts @ 125°C. 1 kilowatt peak (5 μsec pulse width; 1.25% duty cycle).

INTERMODULATION (Model 1429-X-LIM Only): IM3 (Reflected) = -100 dBc with two input signals @ 869 MHz and 891 MHz with an average power of +41 dBm each.

TEMPERATURE RANGE: -55°C to +125°C

TEST DATA: Swept data plots of SWR from 50 MHz to 18 GHz is available at additional cost.

CONNECTOR: Type N connector per MIL-STD-348 interface dimensions - mate nondestructively with MIL-C-39012 connector. Choice of male (-4) or female connector (-3).

3.5mm connector mate nondestructively with SMA per MIL-C-39012, 2.92mm and other 3.5mm connector. Choice of male (-2) or female connector (-1).

CONSTRUCTION: Black, finned aluminum body, stainless steel connector; gold plated beryllium copper female contact or stainless steel male contact.

WEIGHT: 100 g (3.5 oz)

PHYSICAL DIMENSIONS:

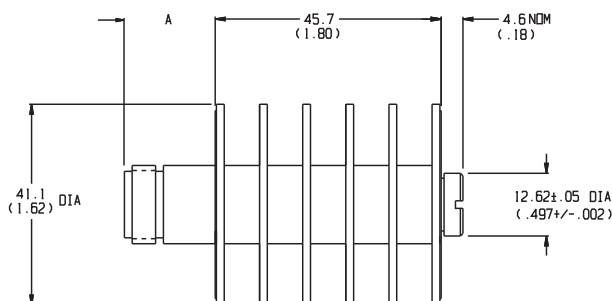

Model #	DIM A	Connector Type
1429-1	13.2 (0.52)	3.5mm female
1429-2	14.0 (0.55)	3.5mm male
1429-3	18.3 (0.72)	N female
1429-4	23.1 (0.91)	N male

NOTE: All dimensions are given in mm (inches) and are maximum, unless otherwise specified.

MODEL NUMBER DESCRIPTION:

Example:

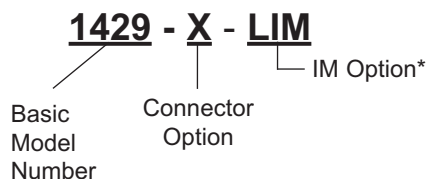

* Add -LIM to entire model number for Low Intermodulation option.

Model 1444 Medium Power, 3.5mm Connectors Convection Cooled

dc to 26.5 GHz
25 Watts

 **RoHS**



TEMPERATURE RANGE: -55°C to +125°C

TEST DATA: Swept data plots of SWR from 50 MHz to 26.5 GHz.

CONNECTOR: 3.5mm connectors - mate nondestructively with SMA per MIL-C-39012, 2.92mm, and other 3.5mm connectors. Choice of male (-2) or female connector (-1).

CONSTRUCTION: Black, finned aluminum body, stainless steel connector; gold plated beryllium copper contacts.

WEIGHT: 100 g (3.5 oz)

PHYSICAL DIMENSIONS:

Features

- /// Designed to meet environmental requirements of MIL-D-39030.
- /// Precision Connectors.
- /// Flat Response.

Specifications

NOMINAL IMPEDANCE: 50 Ω

FREQUENCY RANGE: dc to 26.5 GHz

MAXIMUM SWR:

Frequency (GHz)	SWR
dc - 26.5	1.25

POWER RATING: 25 watts average (**mounted horizontally**) average @ 25°C ambient temperature, derated linearly to 2.5 watt @ 125°C. 500 watts **peak** (5 μsec pulse width; 2.5% duty cycle).

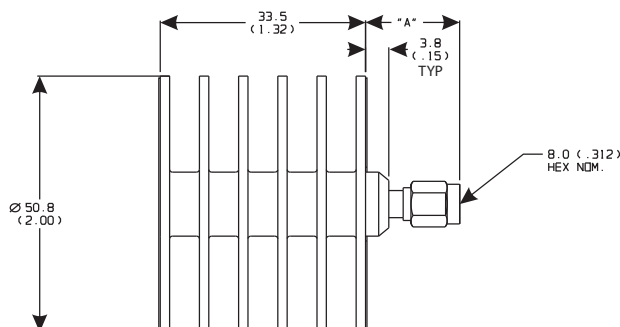

Model #	DIM A	Connector Type
1444-1	15.0 (0.59)	3.5mm female
1444-2	16.0 (0.63)	3.5mm male

NOTE: All dimensions are given in mm (inches) and are maximum, unless otherwise specified.

Terminations & Loads



Model 1468

Medium Power, SMA, N & BNC Connectors

dc to 6.0 GHz

50 Watts

Low Cost Design



CONSTRUCTION: Aluminum alloy body, stainless steel connector; gold plated beryllium copper contacts.

WEIGHT: Net 318 g (11.2 oz.) maximum

PHYSICAL DIMENSIONS:

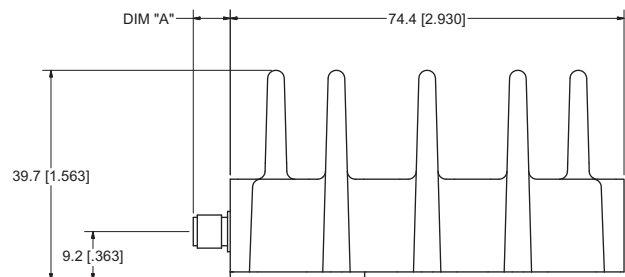

Features

- /// Compact Construction - Lowest size/power ratio.
- /// Quality Injection Molded Connector.
- /// Ideal for high volume OEM Wireless Applications.

Specifications

NOMINAL IMPEDANCE: 50 Ω

FREQUENCY RANGE: dc to 6.0 GHz

MAXIMUM SWR:

Frequency (GHz)	SWR
dc - 4	1.30
4 - 6	1.60

POWER RATING: 50 watts **average** at 25°C ambient temperature derated linearity to 5 Watts at 125°C. 1 kW peak (5 μsec pulse width: 2.5% duty cycle)

TEMPERATURE RANGE: -55°C to 125°C case.

CONNECTOR: SMA or Type N connector per MIL-STD-348 interface dimensions - mates nondestructively with MIL-C-39012 connector.

Connector Options	Type/Description
1	SMA, Female
2	SMA, Male
3	Type N, Female
4	Type N, Male
8	BNC Female
9	BNC Male

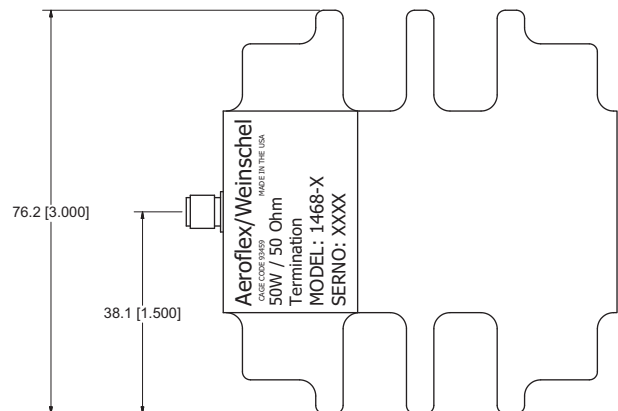

Model #	DIM A	Connector Type
1468-1	7.0 (0.275)	SMA female
1468-2	10.3 (0.405)	SMA male
1468-3	14.9 (0.587)	N female
1468-4	17.8 (0.700)	N male
1468-8		BNC Female
1468-9		BNC Male

NOTE:

1. All dimensions are given in mm (inches) and are maximum, unless otherwise specified.
2. Minimum quantities apply. Contact Factory.

Model 1447 Medium Power, 7/16 Connectors *Low Intermodulation Design*

50 Watts dc to 6.0 GHz



PHYSICAL DIMENSIONS:

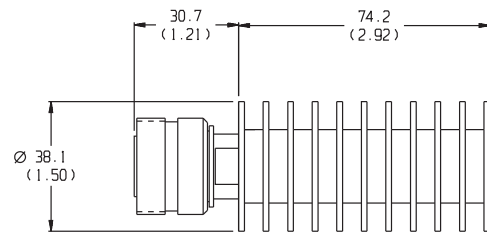

MODEL NO. 1447-1 FEMALE

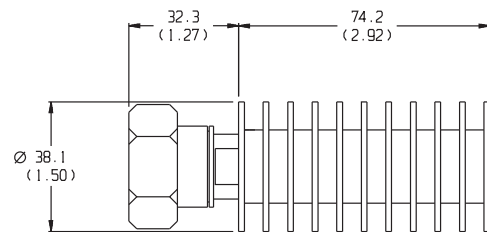

MODEL NO. 1447-2 MALE

NOTE: All dimensions are given in mm (inches) and tolerances are X.X+0.8 (0.03) unless otherwise specified.

Features

- /// Optimized for Wireless OEM and Test Applications.
- /// Designed to meet environmental requirements of MIL-D-39030.
- /// Custom Designs Available.

Specifications

NOMINAL IMPEDANCE: 50 Ω

FREQUENCY RANGE: dc to 6.0 GHz

MAXIMUM SWR:

Frequency (GHz)	SWR
dc - 6	1.20

POWER RATING: (mounted horizontally assuming unobstructed air flow and natural convection around unit): 50 watts **average** to 25°C ambient temperature, derated linearly to 5 watts @ 125°C. 5 kilowatt **peak** (5 μsec pulse width; 0.5% duty cycle).

INTERMODULATION: IM3 (Reflected) = -100 dBc with two +43 dBm Input Tones @ 869 MHz and 891 MHz.

TEMPERATURE RANGE: -55°C to 125°C.

TEST DATA: Swept data plots of SWR from 50 MHz to 6 GHz is available at additional cost.

CONNECTOR: 7/16 connector that conforms to DIN 47 223, IEC 1694, VG 95250, CECC 22190. Choice of 7/16 male(-2) of 7/16 female (-1) connector

CONSTRUCTION: Black, finned aluminum body, silver plated brass connector.

WEIGHT: Net 354 g (12.5 oz) maximum

Terminations & Loads



Model 1426 Medium Power, N & SMK Connectors Convection Cooled

dc to 10 GHz
50 Watts



Features

- /// **Rugged Construction** - Quality connector with special high temperature support bead.
- /// **Low Intermodulation Option**
- /// **5 Kilowatts Peak Power**

Specifications

NOMINAL IMPEDANCE: 50 Ω

FREQUENCY RANGE: dc to 10 GHz

MAXIMUM SWR:	
Frequency (GHz)	SWR
dc - 4	1.20
4 - 10	1.30

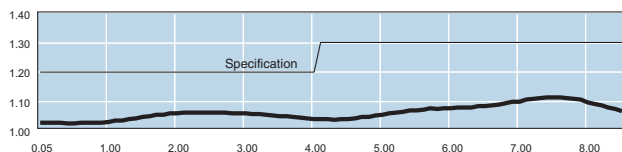

Typical 1426-4 SWR Performance

POWER RATING: 50 watts **average (mounted horizontally)** to 25°C ambient temperature, derated linearly to 5 watts @ 125°C. 5 kilowatts **peak** (5 μsec pulse width; 0.5% duty cycle).

INTERMODULATION (Model 1426-X-LIM Only): IM3 (Reflected) = -100 dBc with two input signals @ 869 MHz and 891 MHz with an average power of +43 dBm each.

TEMPERATURE RANGE: -55°C to +125°C

TEST DATA: Swept data plots of SWR from 50 MHz to 10 GHz is available at additional cost.

CONNECTOR: Type N connector per MIL-STD-348 interface dimensions - mate nondestructively with MIL-C-39012 connector. Choice of male (-4) or female connector (-3).

SMK (2.92mm) connector mates nondestructively with SMA per MIL-C-39012, 3.5mm and other 2.92mm (SMK) connector. Choice of male (-2) or female connector (-1).

CONSTRUCTION: Black, finned aluminum body, stainless steel connector; gold plated beryllium copper female contacts and stainless steel male contacts.

WEIGHT: Net 280 g (10 oz.)

PHYSICAL DIMENSIONS:

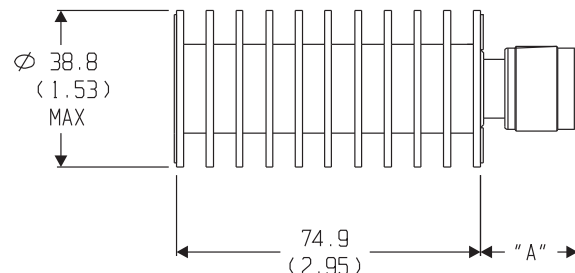

Model #	DIM A	Connector Type
1426-1	12.7 (0.50)	2.92mm female
1426-2	14.0 (0.55)	2.92mm male
1426-3	15.0 (0.59)	N female
1426-4	22.9 (0.90)	N male

NOTE: All dimensions are given in mm (inches) and are maximum, unless otherwise specified.

MODEL NUMBER DESCRIPTION:

Example:

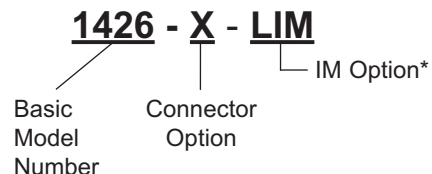

* Add -LIM to entire model number for Low Intermodulation option. Option not available through Express.

Model 1430
Medium Power, N & 3.5mm Connectors
Convection Cooled

dc to 18.0 GHz
50 Watts

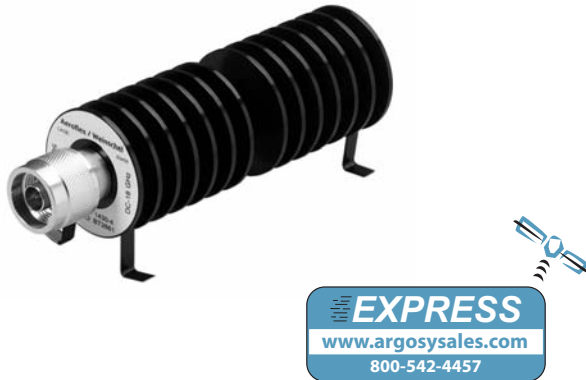

Features

- /// Designed to meet environmental requirements of MIL-D-39030.
- /// Rugged injection molded connector.
- /// 1 Kilowatt Peak Power

Specifications

NOMINAL IMPEDANCE: 50 Ω

FREQUENCY RANGE: dc to 18.0 GHz

MAXIMUM SWR:

Frequency (GHz)	SWR
dc - 8	1.15
8 - 18	1.30

POWER RATING: 50 watts **average (mounted horizontally assuming unobstructed air flow and natural convection around unit) @ 25°C ambient temperature, derated linearly to 5 watts @ 125°C. 1 kilowatt peak (5 μsec pulse width; 2.5% duty cycle).**

INTERMODULATION (Model 1430-X-LIM Only): IM3 (Reflected) = -100 dBc with two input signals @ 869 MHz and 891 MHz with an average power of +43 dBm each.

TEMPERATURE RANGE: -55°C to +125°C

TEST DATA: Swept data plots of SWR from 50 MHz to 18 GHz is available at additional cost.

CONNECTOR: Type N connector - mate nondestructively with MIL-C-39012 connector. Choice of male (-4) or female connector (-3).

3.5mm connector mate nondestructively with SMA per MIL-C-39012, 2.92mm and other 3.5mm connector. Choice of male (-2) or female connector (-1).

CONSTRUCTION: Black, finned aluminum body, stainless steel connector; gold plated beryllium copper female contact or stainless steel male contact.

WEIGHT: 175 g (6 oz)

PHYSICAL DIMENSIONS:

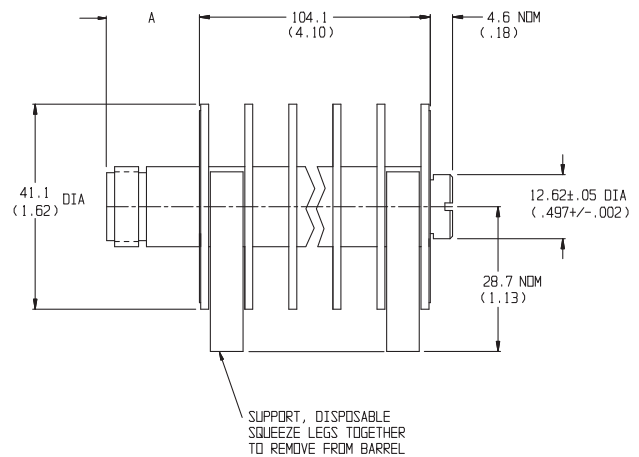

Model #	DIM A	Connector Type
1430-1	13.2 (0.52)	3.5mm female
1430-2	14.0 (0.55)	3.5mm male
1430-3	18.3 (0.72)	N female
1430-4	23.1 (0.91)	N male

NOTE: All dimensions are given in mm (inches) and are maximum, unless otherwise specified.

MODEL NUMBER DESCRIPTION:

Example:

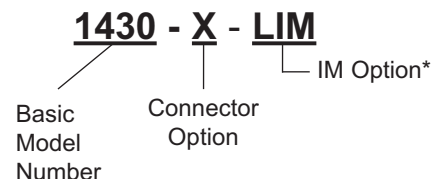

* Add -LIM to entire model number for Low Intermodulation option.

Terminations & Loads



Model 1467 Medium Power, N & 3.5mm Connectors Convection Cooled

dc to 20.0 GHz



50 Watts

RoHS

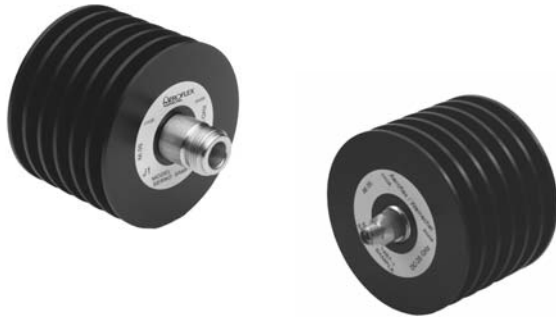

CONNECTOR: Type N connector per MIL-STD-348 interface dimensions - mate nondestructively with MIL-C-39012 connector. Choice of male (-4) or female connector (-3).

3.5mm connector mate nondestructively with SMA per MIL-C-39012, 2.92mm, 3.5mm and other SMA connectors. Choice of male (-2) or female connector (-1).

CONSTRUCTION: Black, finned aluminum body, stainless steel connector; gold plated beryllium copper contacts.

WEIGHT: 100 g (3.5 oz)

PHYSICAL DIMENSIONS:

Features

- /// Designed to meet environmental requirements of MIL-D-39030.
- /// Rugged injection molded connector.
- /// 1 Kilowatt Peak Power

Specifications

NOMINAL IMPEDANCE: 50 Ω

FREQUENCY RANGE: dc to 20.0 GHz

MAXIMUM SWR:	
Frequency (GHz)	SWR (maximum)
dc - 18.0	1.15
18.0 - 20.0	1.20

POWER RATING (mounted horizontally): 50 watts **average** to 25°C ambient temperature, derated linearly to 5 Watts @ 125°C. 1 kW **peak** (5 μsec pulse width; 2.5% duty cycle).

TEMPERATURE RANGE: -55 °C to 125 °C

TEST DATA: Swept data plots of SWR from 50 MHz to 20 GHz is available at additional cost .

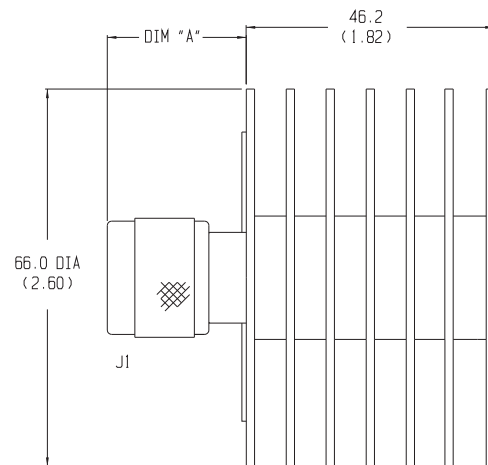

Connector	DIM A	Connector	DIM A
N Male	24.1 (0.95)	3.5mm Female	14.0 (0.55)
N Female	19.0 (0.75)	3.5mm Male	13.2 (0.52)

NOTE: All dimensions are given in mm (inches) and are maximum, unless otherwise specified.

Model 1440 High Power, N or SMK Connectors Convection Cooled

dc to 6.0 GHz
100 Watts

RoHS

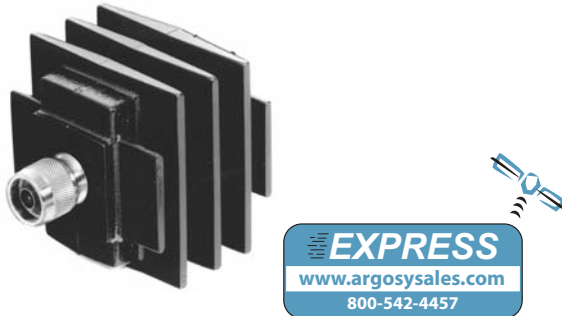

MAXIMUM SWR:

Frequency (GHz)	SWR
dc - 6	1.15

POWER RATING: 100 watts average (mounted horizontally assuming unobstructed air flow and natural convection around unit) to 25°C ambient temperature, derated linearly to 10 watts @ 125°C. 10 kilowatts peak (5 μsec pulse width; 0.5 % duty cycle).

TEMPERATURE RANGE: -55°C to +125°C

TEST DATA: Swept data plots of SWR from 50 MHz to 6 GHz.

CONNECTOR: Type N connector per MIL-STD-348 interface dimensions - mate nondestructively with MIL-C-39012 connector. Choice of male (-4) or female connector (-3).

SMK (2.92mm) connector mates nondestructively with SMA per MIL-C-39012, 3.5mm and other 2.92mm (SMK) connector. Choice of male (-2) or female connector (-1).

CONSTRUCTION: Black, finned aluminum body, stainless steel connector; gold plated beryllium copper center contacts.

WEIGHT: 500 g (18 oz)

Features

- /// **Compact Construction** - Lowest size/power ratio.
- /// **Low SWR**
- /// **Rugged Construction** - Quality connector with special high temperature support bead.
- /// **Ideal for Wireless Applications.**

Specifications

NOMINAL IMPEDANCE: 50 Ω

FREQUENCY RANGE: dc to 6.0 GHz

PHYSICAL DIMENSIONS:

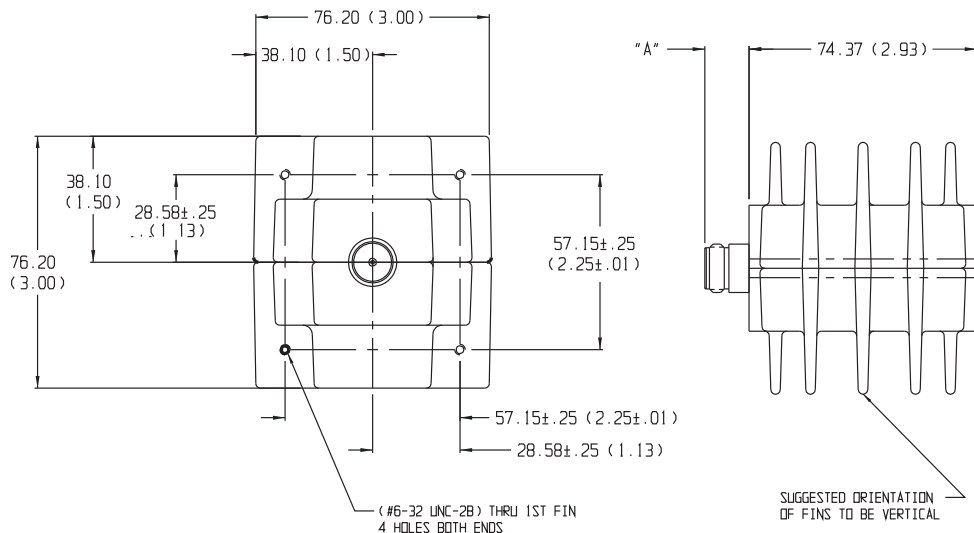

Model #	DIM A	Connector Type
1440-1	12.7 (0.50)	2.92mm female
1440-2	14.0 (0.55)	2.92mm male
1440-3	15.0 (0.59)	N female
1440-4	22.9 (0.90)	N male

NOTE: All dimensions are given in mm (inches) and are maximum, unless otherwise specified.

Terminations & Loads



Model 1442 High Power, N or SMK Connectors Convection Cooled

dc to 10 GHz
100 Watts



Features

- /// **Compact Construction** - Lowest size/power ratio.
- /// **Rugged Construction** - Quality connector with special high temperature support bead.

Specifications

NOMINAL IMPEDANCE: 50 Ω

FREQUENCY RANGE: dc to 10 GHz

POWER RATING (mounted horizontally with fins vertical): 100 watts **average** to 35°C ambient temperature, derated linearly to 10 watts @ 125°C. 5 kilowatts **peak** (5 μsec pulse width; 1.0% duty cycle).

PHYSICAL DIMENSIONS:

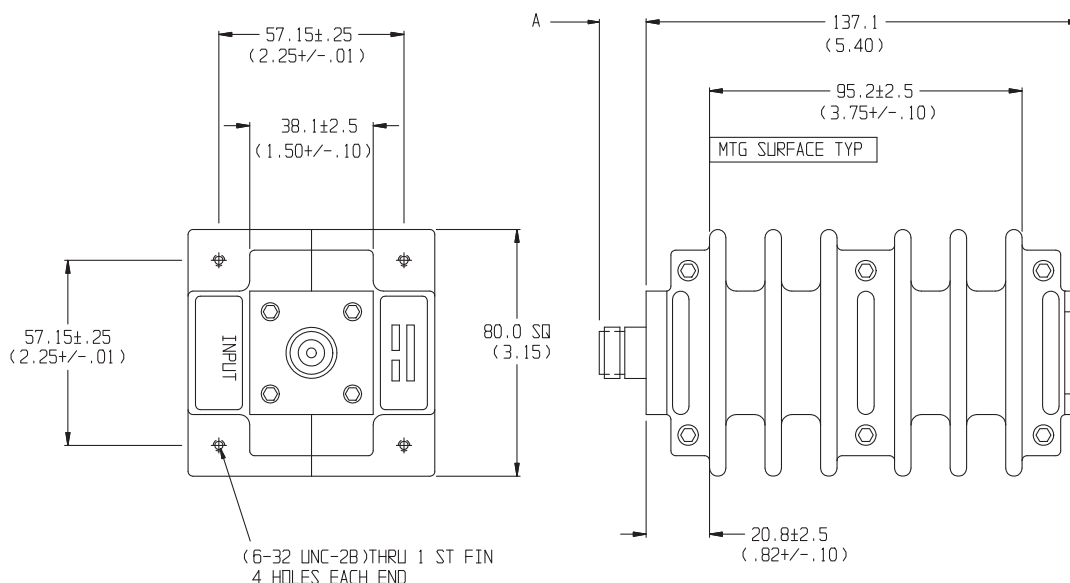

NOTE: All dimensions are given in mm (inches) and are maximum, unless otherwise specified.

MAXIMUM SWR:

Frequency (GHz)	SWR
dc - 4	1.20
4 - 10	1.30

TEMPERATURE RANGE: -55°C to +125°C

TEST DATA: Swept data plots of SWR from 50 MHz to 10 GHz is available at additional cost.

CONNECTOR: Type N connector per MIL-STD-348 interface dimensions - mate nondestructively with MIL-C-39012 connector. Choice of male (-4) or female connector (-3).

SMK (2.92mm) connector mates nondestructively with SMA per MIL-C-39012, 3.5mm and other 2.92mm (SMK) connector. Choice of male (-2) or female connector (-1).

CONSTRUCTION: Black, finned aluminum body, stainless steel connector; gold plated beryllium copper contact or stainless steel male contact.

WEIGHT: 1,130 g (2 lbs, 8 oz)

Model #	DIM A	Connector Type
1442-1	12.7 (0.50)	2.92mm female
1442-2	14.0 (0.55)	2.92mm male
1442-3	15.0 (0.59)	N female
1442-4	22.9 (0.90)	N male

Model 1431 High Power, N & 3.5mm Connectors Convection Cooled

dc to 18.0 GHz
100 Watts

 **RoHS**



Features

- /// Designed to meet environmental requirements of MIL-D-39030.
- /// Rugged injection molded connector.
- /// 1 Kilowatt Peak Power

Specifications

NOMINAL IMPEDANCE: 50 Ω

FREQUENCY RANGE: dc to 18.0 GHz

MAXIMUM SWR:

Frequency (GHz)	SWR
dc - 8	1.20
8 - 18	1.30

POWER RATING: 100 watts average (mounted horizontally assuming unobstructed air flow and natural convection around unit) @ 25°C ambient temperature, derated linearly to 10 watts @ 125°C. 1 kilowatt peak (5 μsec pulse width; 5% duty cycle).

TEMPERATURE RANGE: -55°C to +125°C

TEST DATA: Swept data plots of SWR from 50 MHz to 18 GHz is available at additional cost.

CONNECTOR: Type N connector mates nondestructively with MIL-C-39012 connector. Choice of male (-4) or female connector (-3).

3.5mm connector mates nondestructively with SMA per MIL-C-39012, 2.92mm and other 3.5mm connector. Choice of male (-2) or female connector (-1).

CONSTRUCTION: Black, finned aluminum body, stainless steel connector; gold plated beryllium copper contact or stainless steel male contact.

WEIGHT: 320 g (11 oz)

PHYSICAL DIMENSIONS:

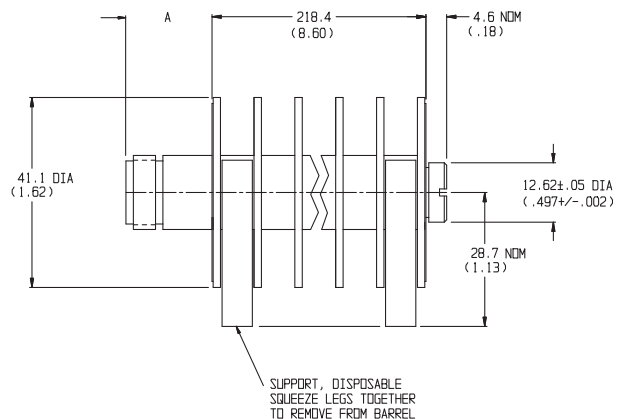

Model #	DIM A	Connector Type
1431-1	13.2 (0.52)	3.5mm female
1431-2	14.0 (0.55)	3.5mm male
1431-3	18.3 (0.72)	N female
1431-4	23.1 (0.91)	N male

NOTE: All dimensions are given in mm (inches) and are maximum, unless otherwise specified.

Terminations & Loads



Model 1469 High Power, N & 3.5mm Connectors Convection Cooled

dc to 18.0 GHz
NEW 100 Watts

RoHS



Features

- /// Designed to meet environmental requirements of MIL-D-39030.
- /// Rugged injection molded connector.
- /// Low Intermodulation Option
- /// 1 Kilowatt Peak Power

Specifications

NOMINAL IMPEDANCE: 50 Ω

FREQUENCY RANGE: dc to 18.0 GHz

MAXIMUM SWR:	
Frequency (GHz)	SWR (maximum)
dc - 18.0	1.15

POWER RATING (mounted horizontally): 100 watts average to 25°C ambient temperature, derated linearly to 10 Watts @ 125°C. 1 kW peak (5 μsec pulse width; 5% duty cycle).

INTERMODULATION (Model 1469-X-LIM Only): IM3 (Reflected) = -100 dBc with two input signals @ 869 MHz and 891 MHz with an average power of +43 dBm each.

TEMPERATURE RANGE: -55 °C to 125 °C

TEST DATA: Swept data plots of SWR from 50 MHz to 18 GHz is available at additional cost.

CONNECTOR: Type N connector per MIL-STD-348 interface dimensions - mate nondestructively with MIL-C-39012 connector. Choice of male (-4) or female connector (-3).

3.5mm connector mates nondestructively with SMA per MIL-C-39012, 2.92mm (SMK) and other 3.5mm connector. Choice of male (-2) or female connector (-1).

CONSTRUCTION: Black, finned aluminum body, stainless steel connector; gold plated beryllium copper contacts.

WEIGHT: 320 g (11.3 oz)

PHYSICAL DIMENSIONS:

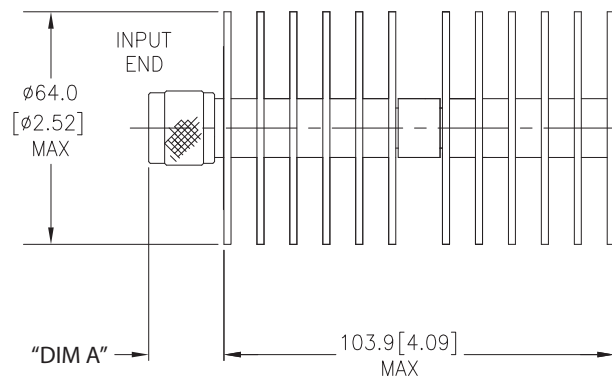

Model #	DIM A	Connector Type
1469-1	12.7 (0.50)	3.5mm female
1469-2	14.0 (0.55)	3.5mm male
1469-3	15.0 (0.59)	N female
1469-4	22.9 (0.90)	N male

NOTE: All dimensions are given in mm (inches) and are maximum, unless otherwise specified.

MODEL NUMBER DESCRIPTION:

Example:

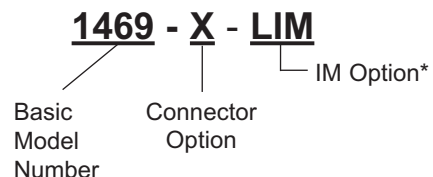

* Add -LIM to entire model number for Low Intermodulation option.

Model 1439 High Power, N or SMK Connectors Conduction / Convection Cooled

dc to 2.5 GHz
150 Watts

RoHS



MAXIMUM SWR*:	
Frequency (GHz)	SWR
dc - 2.5	1.20

POWER RATING: 150 watts average (mounted horizontally or vertically assuming unobstructed air flow and natural convection around unit), 10 kilowatts peak (5 μ sec pulse width; 0.75% duty cycle). Case temperature must be held to **100°C maximum**.

TEMPERATURE RANGE: -55°C to 100°C case

TEST DATA: Swept data plots of SWR from 50 MHz to 2.5 GHz is available at additional cost.

CONNECTOR: Type N connector per MIL-STD-348 interface dimensions - mate nondestructively with MIL-C-39012 connector. Choice of male (-4) or female connector (-3).

SMK (2.92mm) connector mates nondestructively with SMA per MIL-C-39012, 3.5mm and other 2.92mm (SMK) connector. Choice of male (-2) or female connector (-1).

CONSTRUCTION: Black, finned aluminum body, stainless steel connector; gold plated beryllium copper female contact or stainless steel male contact.

WEIGHT: 850 g (1 lb, 14 oz)

Features

- /// **Compact Construction** - Lowest size/power ratio.
- /// **Flexible Mounting Position** - The units may be mounted in horizontal (fins up) or vertical position.
- /// **Rugged Construction** - Quality connector with special high temperature support bead.

Specifications

NOMINAL IMPEDANCE: 50 Ω

FREQUENCY RANGE: dc to 2.5 GHz

PHYSICAL DIMENSIONS:

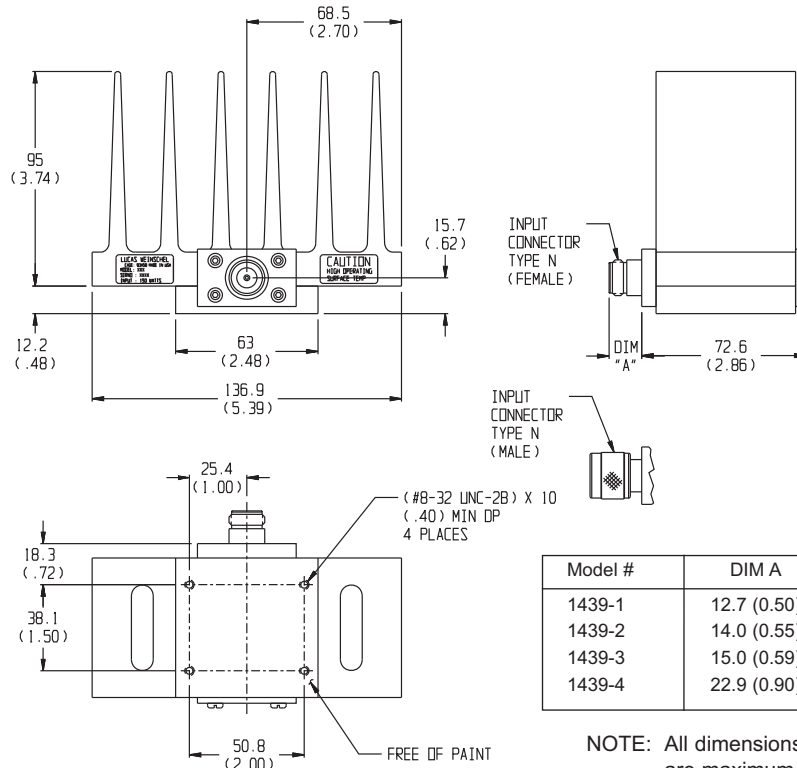

Model #	DIM A	Connector Type
1439-1	12.7 (0.50)	2.92mm female
1439-2	14.0 (0.55)	2.92mm male
1439-3	15.0 (0.59)	N female
1439-4	22.9 (0.90)	N male

NOTE: All dimensions are given in mm (inches) and are maximum, unless otherwise specified.

Terminations & Loads



Model 1428
Model 1435
High Power, N or SMK Connectors
Convection Cooled

dc to 1.5 GHz
dc to 6.0 GHz
150 Watts



POWER RATING: 150 watts average (mounted horizontally assuming unobstructed air flow and natural convection around unit) @ 25°C ambient temperature, derated linearly to 15 watts @ 125°C. 10 kilowatts peak (5 µsec pulse width; 0.75% duty cycle).

TEMPERATURE RANGE: -55°C to +125°C

TEST DATA: Swept data plots of SWR from 50 MHz to 1.5 / 6.0 GHz is available at additional cost.

CONNECTOR: Type N connector per MIL-STD-348 interface dimensions - mate nondestructively with MIL-C-39012 connector.

Model 1428: Add M for male or F for female
 Model 1435: Add -4 for male or -3 for female

SMK (2.92mm) connector mates nondestructively with SMA per MIL-C-39012, 3.5mm and other 2.92mm (SMK) connector. Choice of male (-2) or female connector (-1). Model 1435 Only!

CONSTRUCTION: Black, finned aluminum body, stainless steel connector; gold plated beryllium copper female contact or stainless steel male contact.

WEIGHT: 1,130 g (2 lbs, 8 oz)

MODEL NUMBER DESCRIPTION:

Example:

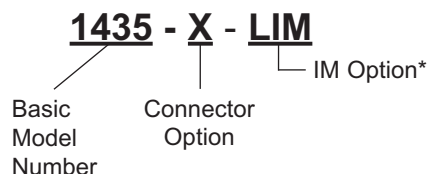

* Add -LIM to entire model number for Low Intermodulation option.

Features

- /// **Low SWR** - Maximum SWR remains low through full frequency and power range.
- /// **Rugged Construction** - Quality connector with special high temperature support beads.

Specifications

NOMINAL IMPEDANCE: 50 Ω

FREQUENCY RANGE: Model 1428: dc to 1.5 GHz
 Model 1435: dc to 6.0 GHz

MAXIMUM SWR:	
Frequency (GHz)	SWR
dc - 2	1.10
2 - 6	1.15

INTERMODULATION (Model 1435-X-LIM Only): IM3 (Reflected) = -100 dBc with two input signals @ 869 MHz and 891 MHz with an average power of +43 dBm each.

PHYSICAL DIMENSIONS:

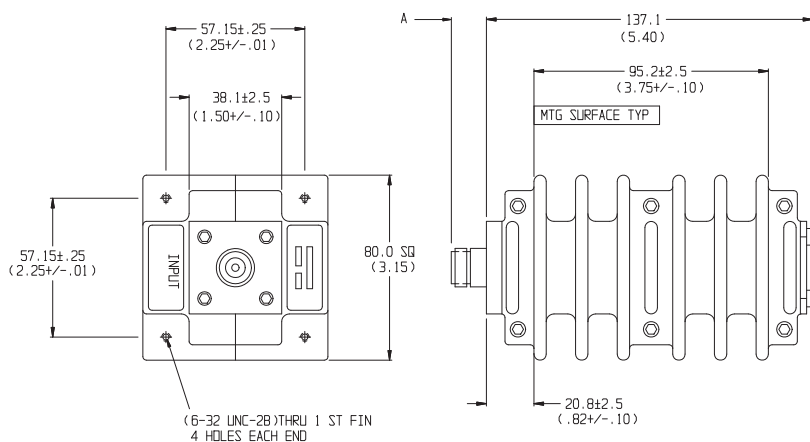

NOTE: All dimensions are given in mm (inches) and are maximum, unless otherwise specified.

Model #	DIM A	Connector Type
1435-1	12.7 (0.50)	2.92mm female
1435-2	14.0 (0.55)	2.92mm male
F1428, 1435-3	15.0 (0.59)	N female
M1428, 1435-4	22.9 (0.90)	N male

Model 1448 High Power, 7/16 Connectors Convection Cooled, Low IMD Design

dc to 6.0 GHz 150 Watts



Features

- /// Optimized for Wireless OEM and Test Applications.
- /// Designed to meet environmental requirements of MIL-D-39030.
- /// Custom Designs Available.

Specifications

NOMINAL IMPEDANCE: 50 Ω

FREQUENCY RANGE: dc to 6.0 GHz

MAXIMUM SWR:

Frequency (GHz)	SWR
dc - 6	1.25

INTERMODULATION: Third Order Reflected Levels (IM3), -100 dBc with two input signals @ 869 MHz and 891 MHz with average carrier power levels of +43 dBm each.

POWER RATING: 150 watts **average (mounted horizontally assuming unobstructed air flow and natural convection around unit)** @ 25°C ambient temperature, derated linearly to 15 watts @ 125°C. 10 kilowatts **peak** (5 μsec pulse width; 0.75% duty cycle).

TEMPERATURE RANGE: -55°C to +125°C

TEST DATA: Swept data plots of SWR from 50 MHz to 6 GHz is available at additional cost.

CONNECTOR: 7/16 connector that conforms to DIN 47 223, IEC 1694, VG 95250, CECC 22190. Choice of 7/16 male (-2) or 7/16 female (-1) connector.

CONSTRUCTION: Black, finned aluminum body, silver plated brass connector.

WEIGHT: 1,248 g (2.75 lbs)

PHYSICAL DIMENSIONS:

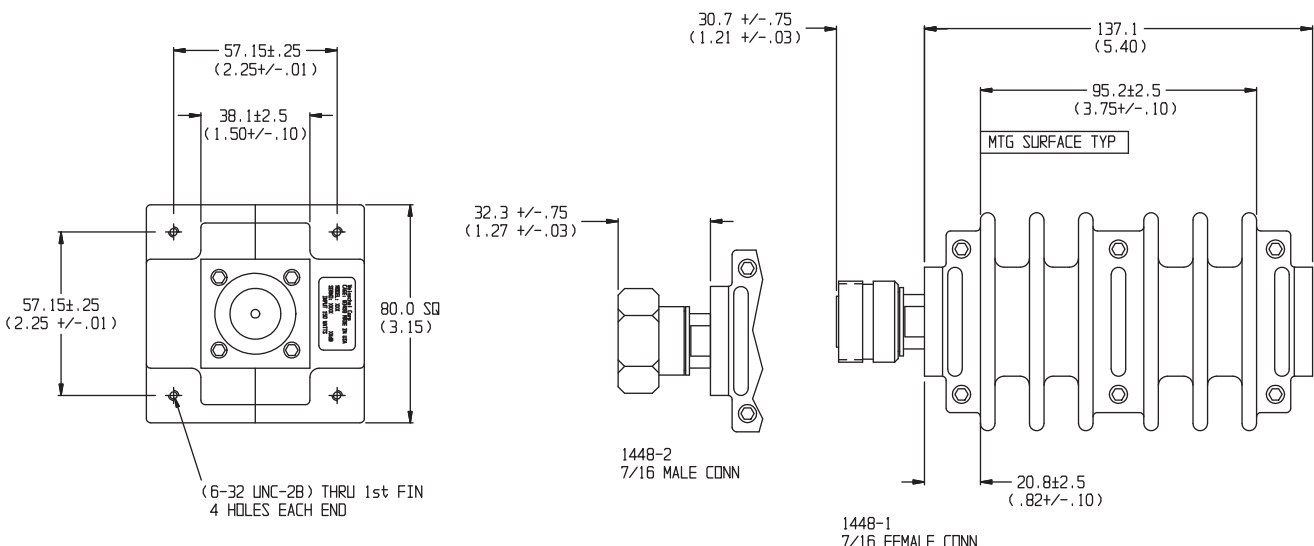

NOTE: All dimensions are given in mm (inches) and are maximum, unless otherwise specified.

Terminations & Loads



Model 1432 High Power, N or SMK Connectors Convection / Conduction Cooled

dc to 10 GHz
150 Watts

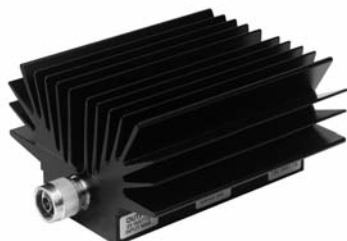

Features

- Flexible Mounting Position - The units may be mounted in horizontal (fins up) or vertical position.
- Rugged Construction - Quality connector with special high temperature support bead.

Specifications

NOMINAL IMPEDANCE: 50 Ω

FREQUENCY RANGE: dc to 10 GHz

MAXIMUM SWR:	
Frequency (GHz)	SWR
dc - 4	1.20
4 - 10	1.30

INTERMODULATION (Model 1432-X-LIM Only): IM3 (Reflected) = -100 dBc with two input signals @ 869 MHz and 891 MHz with an average power of +43 dBm each.

PHYSICAL DIMENSIONS:

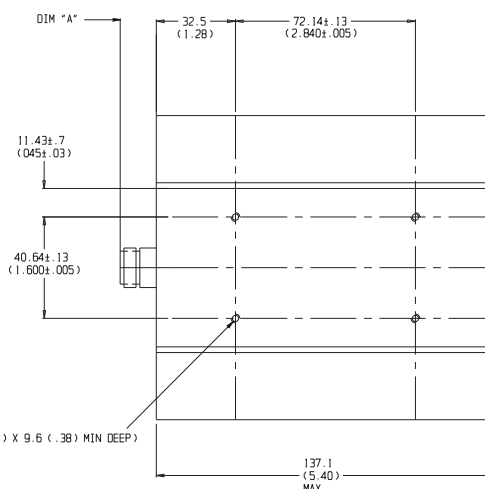
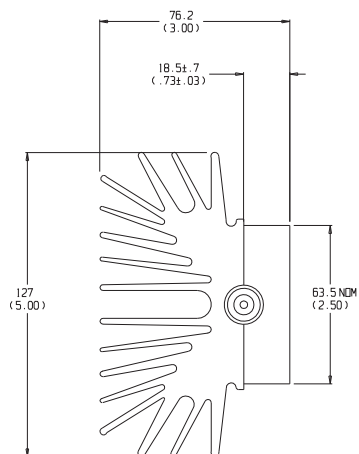

Model #	DIM A	Connector Type
1432-1	12.7 (0.50)	2.92mm female
1432-2	14.0 (0.55)	2.92mm male
1432-3	15.0 (0.59)	N female
1432-4	22.9 (0.90)	N male

POWER RATING: 150 watts average (mounted horizontally or vertically assuming unobstructed air flow and natural convection around unit) to 25°C ambient temperature, derated linearly to 15 watts @ 125°C. 5 kilowatts peak (5 μsec pulse width; 1.5% duty cycle).

TEMPERATURE RANGE: -55°C to +125°C

TEST DATA: Swept data plots of SWR from 50 MHz to 10 GHz is available at additional cost.

CONNECTOR: Type N connector per MIL-STD-348 interface dimensions - mate nondestructively with MIL-C-39012 connector. Choice of male (-4) or female (-3) connector.

SMK (2.92mm) connector mates nondestructively with SMA per MIL-C-39012, 3.5mm and other 2.92mm (SMK) connector. Choice of male (-2) or female connector (-1).

CONSTRUCTION: Black, finned aluminum body, stainless steel connector; gold plated beryllium copper female contacts and stainless steel male contacts.

WEIGHT: 1,450 g (3 lbs., 3 oz.)

MODEL NUMBER DESCRIPTION:

Example:

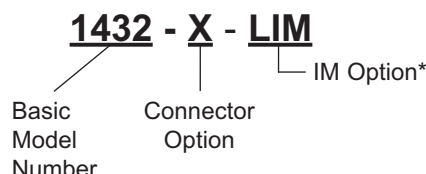

* Add -LIM to entire model number for Low Intermodulation option.

NOTE: All dimensions are given in mm (inches) and are maximum, unless otherwise specified.

Terminations & Loads



Model 1475 High Power, N & 3.5mm Connectors Convection Cooled

dc to 18.0 GHz
150 Watts



Features

- /// Quality injection molded connectors.
- /// Designed to meet environmental requirements of MIL-DTL-3933.
- /// Broadband performance, ideal for test applications.

Specifications

NOMINAL IMPEDANCE: 50 Ω

FREQUENCY RANGE: dc to 18.0 GHz

MAXIMUM SWR:	
Frequency (GHz)	SWR (maximum)
dc - 18.0	1.90

POWER RATING (mounted horizontally): 150 watts average @ case temperature of -55°C to +100 °C maximum. 1 kilowatt peak (5 μsec pulse width; 7.5% duty cycle).

TEMPERATURE RANGE: -55°C to 100°C (case temp.)

TEMPERATURE RANGE: -55°C to +125°C

TEST DATA: Swept data plots of SWR from 50 MHz to 18 GHz is available at additional cost.

CONNECTOR: Type N connector - mate nondestructively with MIL-C-39012 connector. Choice of male (-4) or female connector (-3).

3.5mm connector mate nondestructively with SMA per MIL-C-39012, 2.92mm and other 3.5mm connector. Choice of male (-2) or female connector (-1).

CONSTRUCTION: Aluminum alloy body, stainless steel connectors; gold plated beryllium copper contacts.

WEIGHT: 480 g (17 oz.) maximum

PHYSICAL DIMENSIONS:

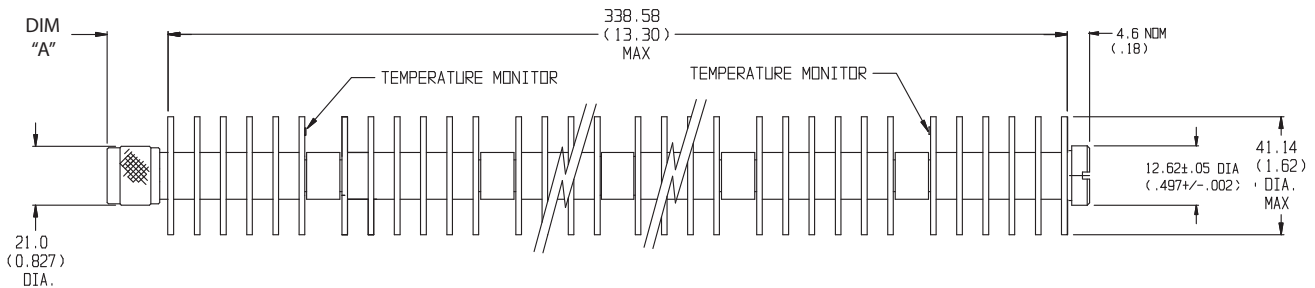

Connector	DIM A	Connector	DIM A
N Male	24.1 (0.95)	3.5mm Female	14.0 (0.55)
N Female	19.0 (0.75)	3.5mm Male	13.2 (0.52)

NOTE: All dimensions are given in mm (inches) and are maximum, unless otherwise specified.

Model 1433 High Power, N Connectors Convection Cooled

dc to 6.0 GHz
250 Watts



INTERMODULATION (Model 1433-X-LIM Only): IM3 (Reflected) = -100 dBc with two input signals @ 869 MHz and 891 MHz with an average power of +43 dBm each.

POWER RATING: 250 watts average (mounted horizontally assuming unobstructed air flow and natural convection around unit) @ 25°C ambient temperature, derated linearly to 25 watts @ 125°C. 10 kilowatts peak (5 µsec pulse width; 1.25% duty cycle).

TEMPERATURE RANGE: -55°C to +125°C

TEST DATA: Swept data plots of SWR from 50 MHz to 6 GHz is available at additional cost-----.

CONNECTOR: Type N connector per MIL-STD-348 interface dimensions - mate nondestructively with MIL-C-39012 connector. Choice of male (-4) or female connector (-3).

CONSTRUCTION: Black, finned aluminum body, stainless steel connector; gold plated beryllium copper female contact or stainless steel male contact.

WEIGHT: Net 1,530 g (3 lbs., 6 oz.) maximum

MODEL NUMBER DESCRIPTION:

Example:

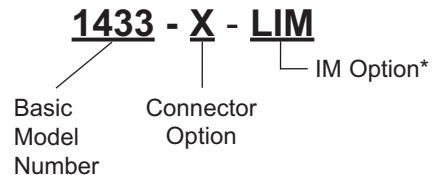

Features

- /// **Compact Construction** - Lowest size/power ratio.
- /// **Low SWR** - Maximum SWR remains low through full frequency and power range.
- /// **Rugged Construction** - Quality connector with special high temperature support beads.

Specifications

NOMINAL IMPEDANCE: 50 Ω

FREQUENCY RANGE: dc to 6.0 GHz

MAXIMUM SWR:

Frequency (GHz)	SWR
dc - 2	1.10
2 - 6	1.15

PHYSICAL DIMENSIONS:

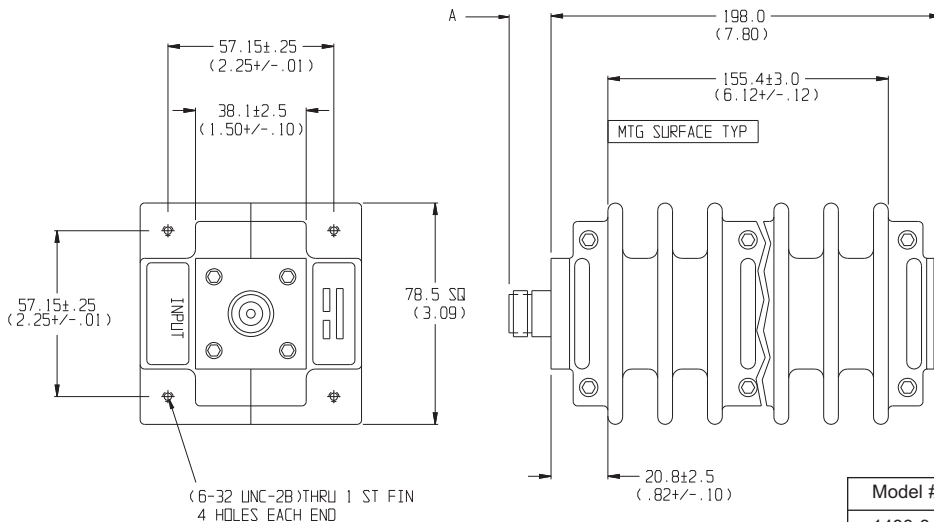

* Add -LIM to entire model number for Low Intermodulation option.

Model #	DIM A	Connector Type
1433-3	15.0 (0.59)	N female
1433-4	22.9 (0.90)	N male

NOTE: All dimensions are given in mm (inches) and are maximum, unless otherwise specified.

Terminations & Loads



Model 1434 High Power, N Connectors Convection Cooled

dc to 2.5 GHz
500 Watts

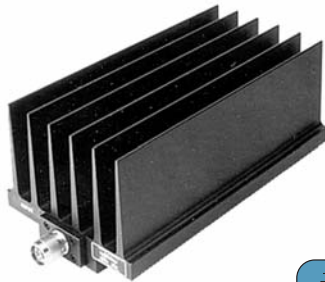

INTERMODULATION (Model 1434-X-LIM Only): IM3 (Reflected) = -100 dBc with two input signals @ 869 MHz and 891 MHz with an average power of +43 dBm each.

POWER RATING: 500 watts average (mounted horizontally assuming unobstructed air flow and natural convection around unit) @ 25°C ambient temperature, derated linearly to 50 watts @ 125°C. 10 kilowatts peak (5 µsec pulse width; 2.5% duty cycle).

TEMPERATURE RANGE: -55°C to +125°C

TEST DATA: Swept data plots of SWR from 50 MHz to 2.5 GHz is available at additional cost.

CONNECTOR: Type N connector per MIL-STD-348 interface dimensions - mate nondestructively with MIL-C-39012 connector. Choice of male (-4) or female (-3) connector.

CONSTRUCTION: Black, finned aluminum body, stainless steel connector; gold plated beryllium copper female contacts and stainless steel male contacts.

WEIGHT: 3,640 g (8 lbs.)

MODEL NUMBER DESCRIPTION:

Example:

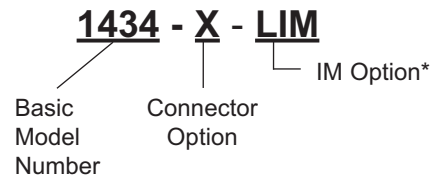

* Add -LIM to entire model number for Low Intermodulation option.

Features

- /// **Compact Construction** - Lowest size/power ratio.
- /// **Low SWR** - Maximum SWR remains low through full frequency and power range.
- /// **Rugged Construction** - Quality connector with special high temperature support bead.

Specifications

NOMINAL IMPEDANCE: 50 Ω

FREQUENCY RANGE: dc to 2.5 GHz

MAXIMUM SWR:

Frequency (GHz)	SWR
dc - 2.5	1.10

PHYSICAL DIMENSIONS:

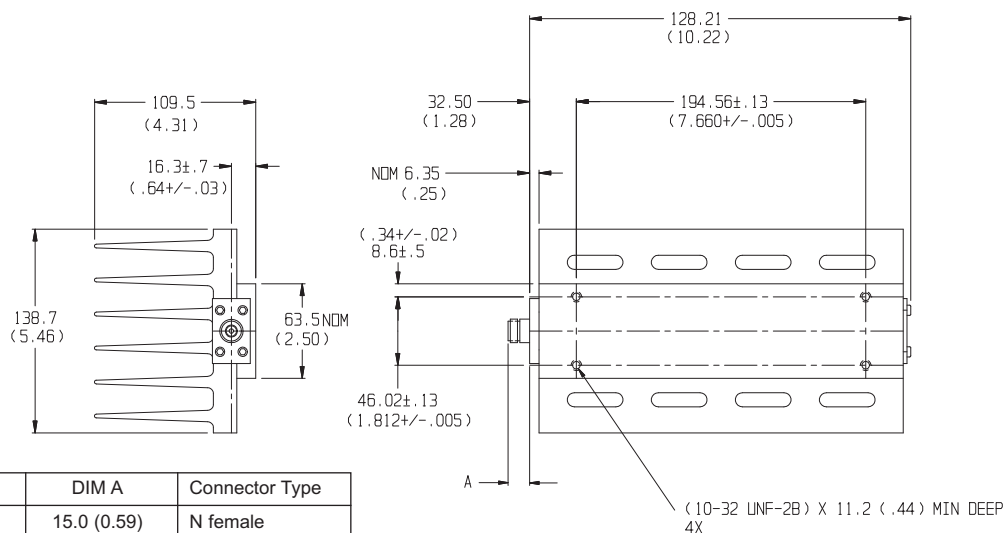

Model #	DIM A	Connector Type
1434-3	15.0 (0.59)	N female
1434-4	22.9 (0.90)	N male

NOTE: All dimensions are given in mm (inches) and are maximum, unless otherwise specified.

Model 1456 High Power, N Connectors Convection Cooled

dc to 3.0 GHz
1,000 Watts

RoHS



Features

- Quality Type N connectors with special high temperature support beads.
- Designed to meet environmental requirements of MIL-D-39030.

Specifications

NOMINAL IMPEDANCE: 50 Ω

FREQUENCY RANGE: dc to 3.0 GHz

MAXIMUM SWR:

Frequency (GHz)	SWR
dc - 1.5	1.15
1.5 - 3.0	1.25

POWER RATING: 1,000 watts average (assuming unobstructed air flow and natural convection around unit) to 25°C ambient temperature, derated linearly to 100 watts @ 125°C. 10 kilowatt peak (5 μsec pulse width; 5% duty cycle).

TEMPERATURE RANGE: -55°C to +125°C with Power derating applied.

TEST DATA: Swept data plots of SWR from 50 MHz to 3 GHz is available at additional cost.

CONNECTOR: Type N connectors - mate nondestructively with MIL-C-39012 connector.

Connector Options	Type/Description
3	Type N, Female
4	Type N, Male

CONSTRUCTION: Black, finned aluminum body, stainless steel or silver plated brass connectors with gold plated beryllium copper or silver plated contacts.

WEIGHT: Net 13 kg (28.7 lbs) maximum

PHYSICAL DIMENSIONS:

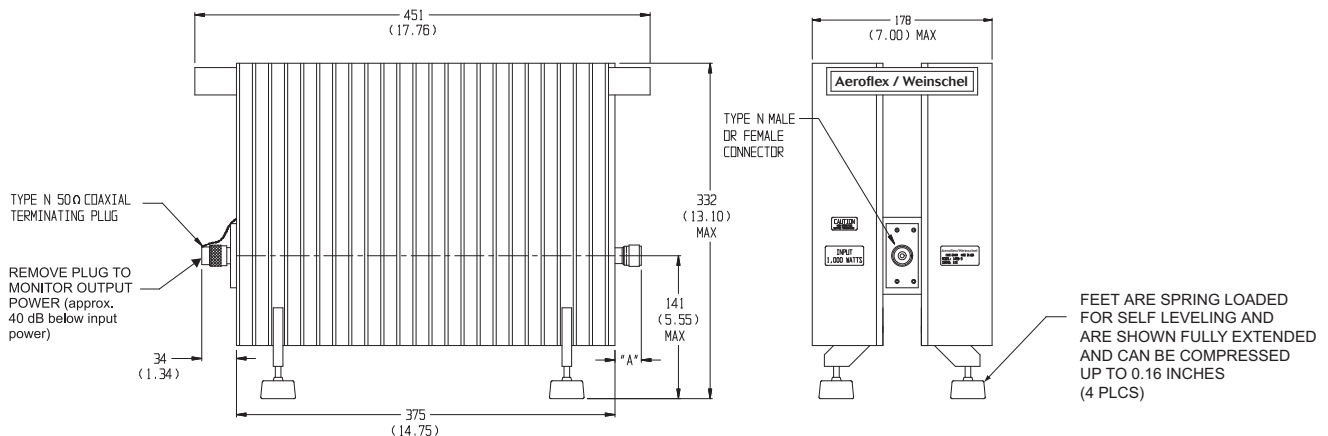

Model #	DIM A	Connector Type
1456-3	15.0 (0.59)	N female
1456-4	22.9 (0.90)	N male

NOTE: All dimensions are given in mm (inches) and are maximum, unless otherwise specified.

Terminations & Loads



Models 1474 SMK Connectors Conduction Cooled

dc to 40.0 GHz
5 Watts



Features

- /// **Compact Construction** - Lowest size/power ratio.
- /// **Rugged Construction** - Quality connector with special high temperature support bead.
- /// **Ideal for Space & Airborne Applications**

Specifications

NOMINAL IMPEDANCE: 50 Ω

FREQUENCY RANGE: dc to 40.0 GHz

MAXIMUM SWR:	
Frequency (GHz)	SWR
dc - 26.5	1.25
26.5 - 40	1.45

POWER RATING: 5 watts **average** with case temperature limited to 100 °C with appropriate conductive heat sink. 200 watts **peak** (5 μsec pulse width; 1.25% duty cycle).

TEMPERATURE COEFFICIENT: <0.0004 dB/dB/°C

TEMPERATURE RANGE: -55 °C to 100 °C (case)

TEST DATA: Swept data plots of attenuation and SWR

from 50 MHz to 40 GHz is available at additional cost.

CONNECTORS: SMK (2.92mm) Male/Female connectors - mate nondestructively with SMA per MIL-C-39012, 3.5mm and other 2.92mm connectors.

Connector Options	Type/Description
1	SMK, Female
2	SMK, Male

CONSTRUCTION: Aluminum body, gold plated beryllium copper contacts.

WEIGHT: 17 g (0.6 oz.) maximum

PHYSICAL DIMENSIONS:

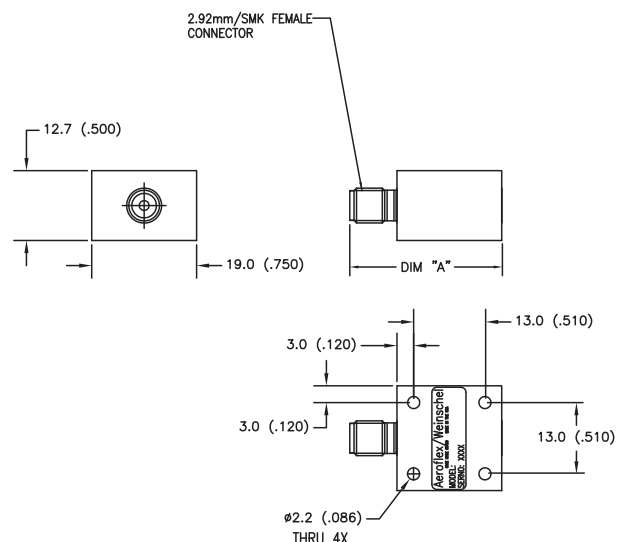

NOTE: All dimensions are given in mm (inches) and are maximum, unless otherwise specified.

Model 1441 Medium Power, N or SMK Connectors Conduction Cooled

dc to 4.0 GHz
50 Watts

 **RoHS**



Features

- /// **Compact Construction** - Lowest size/power ratio.
- /// **Rugged Construction** - Quality connector with special high temperature support bead.
- /// **Ideal for Wireless Applications.**

Specifications

NOMINAL IMPEDANCE: 50 Ω

FREQUENCY RANGE: dc to 4.0 GHz

MAXIMUM SWR:

Frequency (GHz)	SWR
dc - 4	1.15

POWER RATING: 50 watts **average**, 5 kilowatts **peak** (5 μsec pulse width; 0.5% duty cycle) with case temperature held within **100°C maximum** with appropriate conductive heatsink.

TEMPERATURE RANGE: -55°C to 100°C case.

TEST DATA: Swept data plots of SWR from 50 MHz to 4 GHz is available at additional cost.

CONNECTOR: Type N connector per MIL-STD-348 interface dimensions - mate nondestructively with MIL-C-39012 connector. Choice of male (-4) or female (-3) connector.

SMK (2.92mm) connector mates nondestructively with SMA per MIL-C-39012, 3.5mm and other 2.92mm (SMK) connector. Choice of male (-2) or female connector (-1).

CONSTRUCTION: Aluminum alloy body, stainless steel connector; gold plated beryllium copper contacts.

WEIGHT: Net 170g (6 oz.) maximum

PHYSICAL DIMENSIONS:

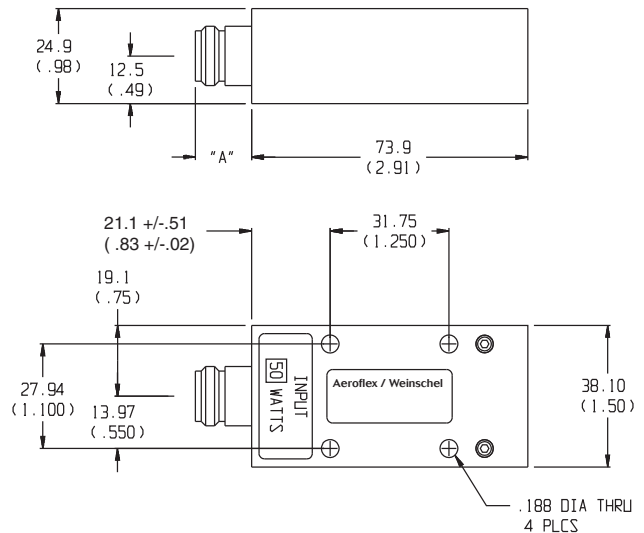

Model #	DIM A	Connector Type
1441-1	12.7 (0.50)	2.92mm female
1441-2	14.0 (0.55)	2.92mm male
1441-3	15.0 (0.59)	N female
1441-4	22.9 (0.90)	N male

NOTE: All dimensions are given in mm (inches) and are maximum, unless otherwise specified.

Terminations & Loads



Model 1476 Medium Power, N or SMK Connectors Conduction Cooled

dc to 10.0 GHz
50 Watts



PHYSICAL DIMENSIONS:

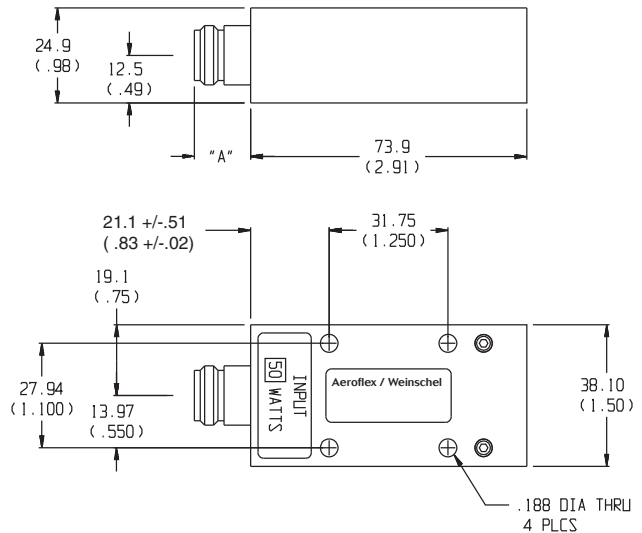

Features

- /// **Compact Construction** - Lowest size/power ratio.
- /// **Rugged Construction** - Quality connector with special high temperature support bead.
- /// **Ideal for Wireless Applications.**

Specifications

NOMINAL IMPEDANCE: 50 Ω
FREQUENCY RANGE: dc to 10.0 GHz

MAXIMUM SWR:	
Frequency (GHz)	SWR
dc - 4	1.15
4 - 10	1.30

Model #	DIM A	Connector Type
1476-1	12.7 (0.50)	2.92mm female
1476-2	14.0 (0.55)	2.92mm male
1476-3	15.0 (0.59)	N female
1476-4	22.9 (0.90)	N male

POWER RATING: 50 watts **average**, 5 kilowatts **peak** (5 μsec pulse width; 0.5% duty cycle) with case temperature held within **100°C maximum** with appropriate conductive heatsink.

TEMPERATURE RANGE: -55°C to 100°C case.

TEST DATA: Swept data plots of SWR from 50 MHz to 10 GHz is available at additional cost.

CONNECTOR: Type N connector per MIL-STD-348 interface dimensions - mate nondestructively with MIL-C-39012 connector. Choice of male (-4) or female (-3) connector.

SMK (2.92mm) connector mates nondestructively with SMA per MIL-C-39012, 3.5mm and other 2.92mm (SMK) connector. Choice of male (-2) or female connector (-1).

CONSTRUCTION: Aluminum alloy body, stainless steel connector; gold plated beryllium copper contacts.

WEIGHT: Net 170g (6 oz.) maximum

NOTE: All dimensions are given in mm (inches) and are maximum, unless otherwise specified.

Terminations & Loads



Models 1458 Medium Power, 3.5mm Connectors Conduction Cooled

dc to 22.0 GHz
50 Watts



PHYSICAL DIMENSIONS:

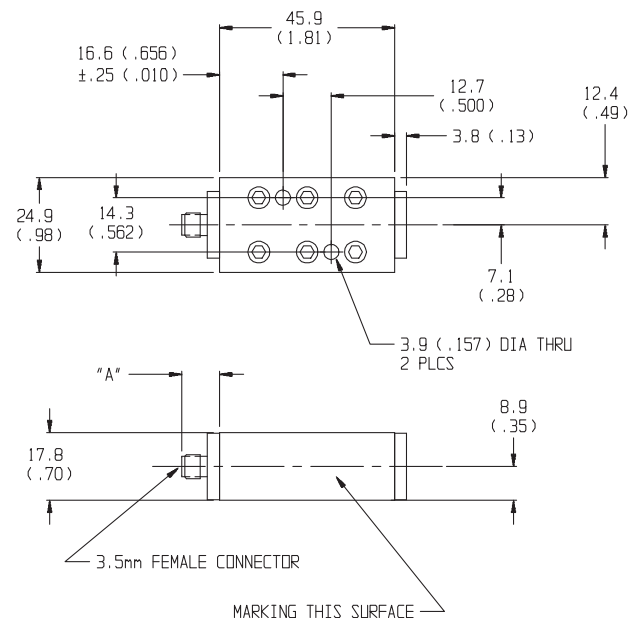

Features

- /// **Compact Construction** - Lowest size/power ratio.
- /// **Rugged Construction** - Quality connector with special high temperature support bead.
- /// **Ideal for Space & Airborne Applications**

Specifications

NOMINAL IMPEDANCE: 50 Ω

FREQUENCY RANGE: dc to 22.0 GHz

MAXIMUM SWR:

Frequency (GHz)	SWR
dc - 22.0	1.30

POWER RATING: 50 watts **average**, 1 kilowatts **peak** (5 μsec pulse width; 2.5% duty cycle) with case temperature held within **90°C maximum** with appropriate conductive heatsink.

TEMPERATURE RANGE: -55°C to 90°C case.

TEST DATA: Swept data plots of SWR from 50 MHz to 22 GHz is available at additional cost.

CONNECTOR: 3.5mm connectors - mate nondestructively with SMA per MIL-C-39012, 2.92mm, and other 3.5mm connectors. Choice of male (-2) or female connector (-1).

CONSTRUCTION: Aluminum alloy body, stainless steel connector; gold plated beryllium copper contacts.

WEIGHT: Net 56 g (1.9 oz) maximum

Model #	DIM A	Connector Type
1458-1	9.9±0.5 (0.35±0.02)	3.5mm female
1458-2	13.4±0.5 (0.53±0.02)	3.5mm male

NOTE: All dimensions are given in mm (inches) and are maximum, unless otherwise specified.

Model 1470 High Power, N or SMK Connectors Conduction Cooled



dc to 6.0 GHz
100 Watts



Features

- /// Precision Connectors with high temperature support beads.
- /// Designed to meet environmental requirements of MIL-DTL-3933.
- /// 10 Kilowatts peak, Conduction Cooled
- /// Wireless Applications - Optimized for use in the communications bands.

Specifications

NOMINAL IMPEDANCE: 50 Ω
FREQUENCY RANGE: dc to 6.0 GHz

MAXIMUM SWR:

Frequency (GHz)	SWR
dc - 6	1.20

3rd ORDER INTERMODULATION (1470-X-LIM ONLY): Reflected Levels (IM3), -100 dBc with two input signals @ 869 MHz and 891 MHz with average carrier power levels of +43 dBm each.

POWER RATING (mounted horizontally): 100 watts average (unidirectional), 10 kilowatt peak (5 μsec pulse width; 0.5% duty cycle) with case temperature held within **100 °C maximum** with appropriate conductive heat sink.

TEMPERATURE RANGE: -55°C to 100°C

TEST DATA: Swept data plots of SWR from 50 MHz to 6 GHz is available at additional cost.

CONNECTORS: Type N connector per MIL-STD-348 interface dimensions - mate nondestructively with MIL-C-39012 connector. Choice of male (-4) or female connector (-3).

SMK (2.92mm) connector mates nondestructively with SMA per MIL-C-39012, 3.5mm and other 2.92mm (SMK) connector. Choice of male (-2) or female connector (-1).

CONSTRUCTION: Aluminum alloy body, stainless steel connectors; gold plated beryllium copper contacts.

WEIGHT: 300 g (10.6 oz.) maximum

PHYSICAL DIMENSIONS:

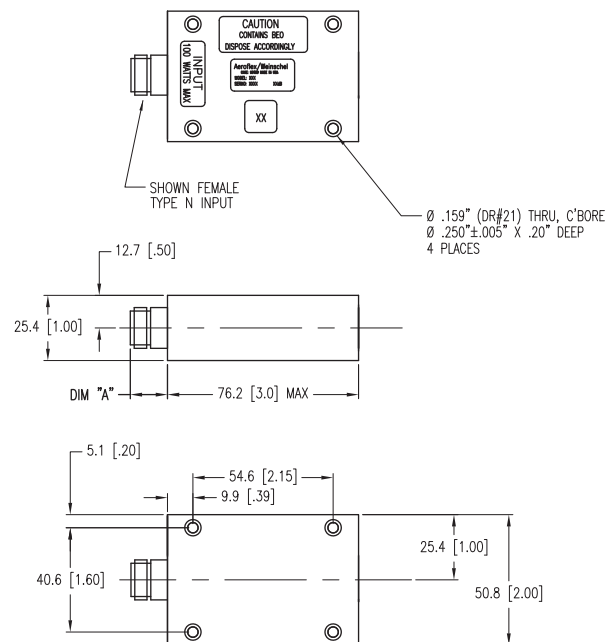

Model #	DIM A	Connector Type
1470-1	12.7 (0.50)	2.92mm female
1470-2	14.0 (0.55)	2.92mm male
1470-3	15.0 (0.59)	N female
1470-4	22.9 (0.90)	N male

NOTE: All dimensions are given in mm (inches) and are nominal, unless otherwise specified.

MODEL NUMBER DESCRIPTION:

Example:

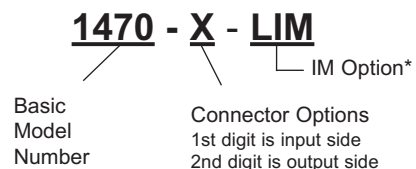

* Add -LIM to entire model number for Low Intermodulation option.

Model 1472 High Power, N or SMK Connectors Conduction Cooled



dc to 6.0 GHz
400 Watts



CONSTRUCTION: Aluminum alloy body, stainless steel connectors; gold plated beryllium copper contacts.

WEIGHT: 700 g (24.6 oz.) maximum

PHYSICAL DIMENSIONS:

Features

- /// Precision Connectors with high temperature support beads.
- /// Designed to meet environmental requirements of MIL-DTL-3933.
- /// 10 Kilowatts peak, Conduction Cooled
- /// Wireless Applications - Optimized for use in the communications bands.

Specifications

NOMINAL IMPEDANCE: 50 Ω

FREQUENCY RANGE: dc to 6.0 GHz

MAXIMUM SWR:

Frequency (GHz)	SWR
dc - 6	1.20

3rd ORDER INTERMODULATION (1472-X-LIM ONLY): Reflected Levels (IM3), -100 dBc with two input signals @ 869 MHz and 891 MHz with average carrier power levels of +43 dBm each.

POWER RATING: 400 watts **average**, 10 kilowatt **peak** (5 μsec pulse width; 2.0% duty cycle) with case temperature held within **100 °C maximum** with appropriate conductive heat sink.

TEMPERATURE RANGE: -55°C to 100°C

TEST DATA: Swept data plots of SWR from 50 MHz to 6 GHz is available at additional cost.

CONNECTORS: Type N connector per MIL-STD-348 interface dimensions - mate nondestructively with MIL-C-39012 connector. Choice of male (-4) or female connector (-3).

SMK (2.92mm) connector mates nondestructively with SMA per MIL-C-39012, 3.5mm and other 2.92mm (SMK) connector. Choice of male (-2) or female connector (-1).

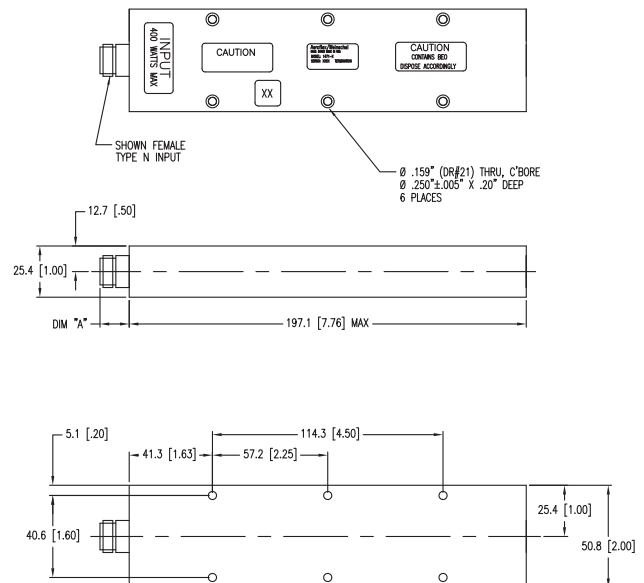

Model #	DIM A	Connector Type
1472-1	12.7 (0.50)	2.92mm female
1472-2	14.0 (0.55)	2.92mm male
1472-3	15.0 (0.59)	N female
1472-4	22.9 (0.90)	N male

NOTE: All dimensions are given in mm (inches) and are nominal, unless otherwise specified.

MODEL NUMBER DESCRIPTION:

Example:

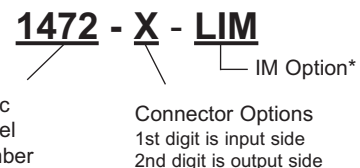

* Add -LIM to entire model number for Low Intermodulation option.

Terminations & Loads



Model 1473 High Power, N or SMK Connectors Conduction Cooled



dc to 6.0 GHz
550 Watts



CONSTRUCTION: Aluminum alloy body, stainless steel connectors; gold plated beryllium copper contacts and stainless steel male contacts.

WEIGHT: 900 g (31.7 oz.)

PHYSICAL DIMENSIONS:

Features

- /// Precision Connectors with high temperature support beads.
- /// Designed to meet environmental requirements of MIL-DTL-3933.
- /// 10 Kilowatts peak, Conduction Cooled
- /// Wireless Applications - Optimized for use in the communications bands.

Specifications

NOMINAL IMPEDANCE: 50 Ω

FREQUENCY RANGE: dc to 6.0 GHz

MAXIMUM SWR:	
Frequency (GHz)	SWR
dc - 6	1.20

3rd ORDER INTERMODULATION (1473-X-LIM ONLY): Reflected Levels (IM3), -100 dBc with two input signals @ 869 MHz and 891 MHz with average carrier power levels of +43 dBm each.

POWER RATING: 550 watts **average**, 10 kilowatt **peak** (5 μsec pulse width; 2.75% duty cycle) with case temperature held within **100 °C maximum** with appropriate conductive heat sink.

TEMPERATURE RANGE: -55°C to 100°C

TEST DATA: Swept data plots of SWR from 50 MHz to 6 GHz is available at additional cost.

CONNECTORS: Type N connector per MIL-STD-348 interface dimensions - mate nondestructively with MIL-C-39012 connector. Choice of male (-4) or female connector (-3).

SMK (2.92mm) connector mates nondestructively with SMA per MIL-C-39012, 3.5mm and other 2.92mm (SMK) connector. Choice of male (-2) or female connector (-1).

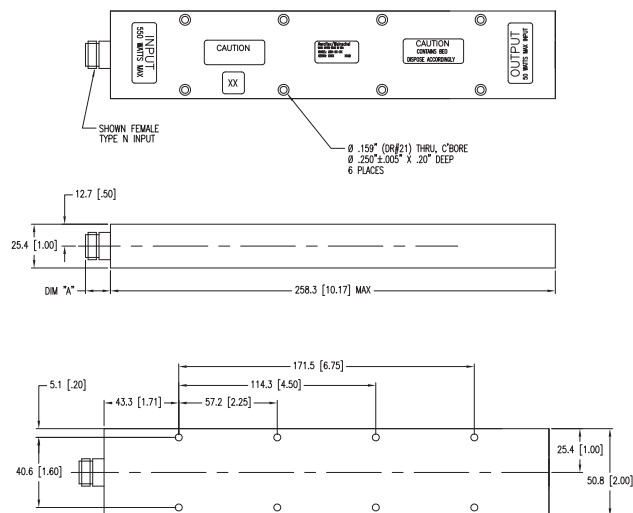

Model #	DIM A	Connector Type
1473-1	12.7 (0.50)	2.92mm female
1473-2	14.0 (0.55)	2.92mm male
1473-3	15.0 (0.59)	N female
1473-4	22.9 (0.90)	N male

NOTE: All dimensions are given in mm (inches) and are nominal, unless otherwise specified.

MODEL NUMBER DESCRIPTION:

Example:

1473 - X - LIM
IM Option*

Basic Model Number

Connector Options
1st digit is input side
2nd digit is output side

* Add -LIM to entire model number for Low Intermodulation option.

Model 1591 TNC Connectors Simplifies Test Setups

dc to 2.0 GHz
1 Watt



Features

- Miniature Size & Lightweight.
- 3-Port Cal Design for wireless communication test applications.

Specifications

NOMINAL IMPEDANCE: 50 Ω
FREQUENCY RANGE: dc to 2.0 GHz
MAXIMUM INPUT POWER: 2 watt CW, 500 watt pulse
PHYSICAL DIMENSIONS:

MAXIMUM SWR (Load Port):

Frequency (GHz)	SWR
dc - 1	1.05
1 - 2	1.35

MAXIMUM PHASE TRACKING (Short / Open):

Frequency (GHz)	Tracking °
dc - 1	3°
1 - 2	7°

TEMPERATURE RANGE: -55°C to +125°C

CONSTRUCTION: Aluminum body and connectors; gold plated beryllium copper contacts.

TEST DATA: Test data can be provided at additional cost.

CONNECTORS: Female TNC connectors all ports-- - mate nondestructively with MIL-C-39012 connectors.

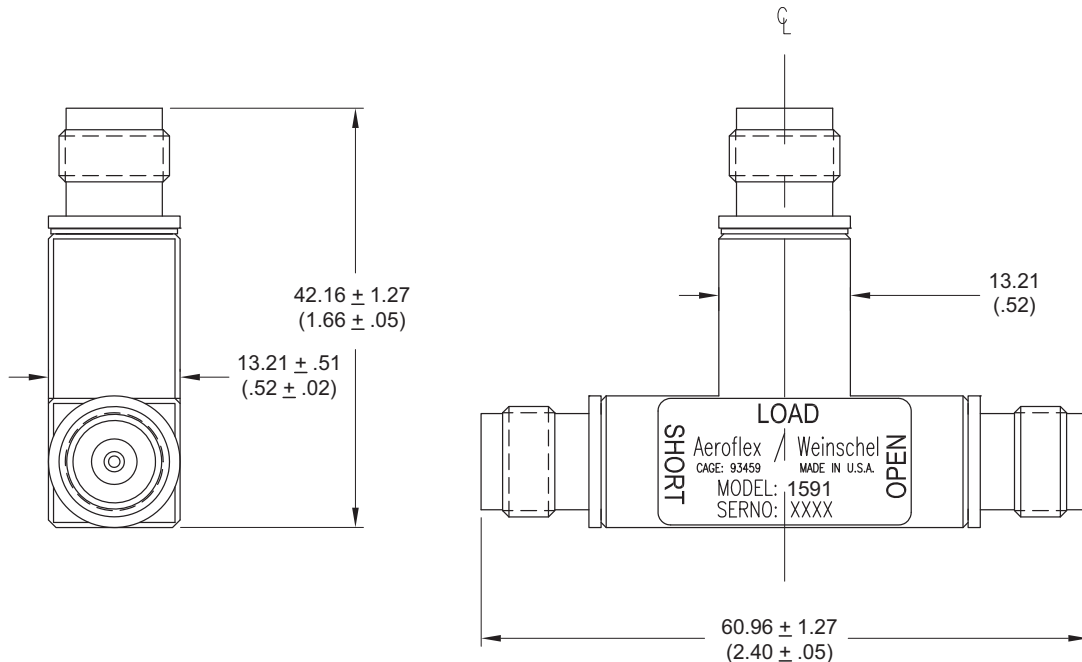

NOTE: All dimensions are given in mm (inches) and are maximum, unless otherwise specified

Variable Attenuators (Step & Continuously)



- /// Wide Choice of Attenuation & Frequency Ranges.
- /// High Reliability & Long Life
- /// Rugged Construction & Connectors
- /// Rotational Stops Included on most models
- /// Low Cost Designs - Model 3056
- /// Custom Designs Available

General Information

In this section of the catalog, each Manual Step and Variable Attenuator is outlined utilizing individual data sheets containing product features, specifications, and outline drawings. These data sheets are preceded by a quick reference guide to help you select the Manual Step and Variable(s) that fits your needs. The page number for each Step Attenuator data sheet is given in the quick reference guide.

NOTE: *EXPRESS* Shipment available via www.argosysales.com or 800-542-4457. Check with distributor for current products and stocking quantities.



Continuously Variable Attenuators...dc-4.2 GHz



Frequency Model Number	Average Range (GHz)	Peak Power (Watts)	Residual Power (Watts)	Maximum Insertion Loss (dB)	Attenuation Range (dB)	Maximum SWR	Connector Type	Page No.
♦ 940-60 940-114	dc-4.0 dc-2.0	5	500	6	60 114	1.80 1.60	SMA/N SMA/N	136



Manual Step Attenuators...dc-26.5 GHz



Model Number	Frequency Range (GHz)	Incremental Attenuation Range (dB)	Insertion Loss (dB)	Average Power (Watts)	Peak Power (Watts)	Maximum SWR	Connector Type	Page No.
♦ 3003 3006 3007	dc-2.50 dc-1.25 dc-2.5	0-70/10 0-100/10 0-10/1	0.3 0.2 0.3	1	100	1.20 1.20 1.30	SMA	139
♦ 3010 3014	dc-2.5 dc-1.25	0-70/1 0-110/1	0.7 0.5			1.35 1.30		
♦ 3053 ♦ 3054	dc-6.0 dc-6.0	0-10/1 0-70/1	0.3-0.7* 0.8-1.3*			1.3-1.4* 1.3-1.55*	SMA	141
3056 <i>New</i>	dc-3.0	0-70/1	0.25-0.35*	1	100	1.30-1.40*	SMA	138
AC9009 ♦ AC9003 AC9004 AC9010 AC9011	dc-4.0	0-9/1 0-69/1 0-99/1 0-60/10 0-90/10	0.3 0.6 0.6 0.4 0.5	2	200	1.25 1.35 1.35 1.35 1.35	SMA	143
♦ AF9009 ♦ AF9003 AF9004 AF9010 AF9011	dc-18.0	0-9/1 0-69/1 0-99/1 0-60/10 0-90/10	0.3-1.0* 0.6-1.5* 0.6-1.5* 0.4-1.0* 0.5-1.0*	2	200	1.60 1.75 1.75 1.60 1.60	SMA	
9012-9 9012-70	dc-26.5	0-9/1 0-70/10	1.0-1.5* 1.0 or 2%	2	200	1.45-1.50*	2.92mm	149
AC115A AC116A AC117A AC118A AC119A	dc-4.0	0-9/1 0-60/10 0-69/1 0-90/10 0-99/1	0.3 0.3-0.4** 0.5-0.6** 0.4-0.5** 0.5-0.6**	2	200	1.25-1.30* 1.25-1.30* 1.50 1.25-1.30* 1.35-1.70*	SMA/N	146
AF115A AF116A AF117A AF118A AF119A	dc-18.0	0-9/1 0-60/10 0-69/1 0-90/10 0-99/1	0.7-1.0** 0.7-1.0** 1.2-1.5** 0.8-1.02** 1.2-15**	2	200	1.60 1.60 1.70 1.60 1.70	SMA/N	



* VARIES WITH FREQUENCY.

- ♦ EXPRESS Shipment available via www.argosysales.com or 800-542-4457.
Note: Other models may also be available from Express delivery.

Frequently Asked Questions about Variable & Manual Step Attenuators....

What are the applications for Weinschel's variable/manual step attenuators?

Continuously Variable Attenuators are used in applications where the need exists for controlling signal levels continuously without interrupting the circuit. Most Weinschel models are in linear scales, and have low frequency sensitivity with broad frequency coverage, resulting from the use of proven Aeroflex / Weinschel resistive films. The resistive elements located in these Variable Attenuators provide long-term stability over temperature and humidity.



Manual Step Attenuators are primarily used in areas demanding broadband accuracy with low SWR and accurate repeatability over large attenuation ranges. The Weinschel Step Attenuators utilize the excellent performance characteristics of the Weinschel fixed coaxial attenuators. The Weinschel step attenuators are widely used in many types of ATE and OEM systems operating throughout the world.

Aeroflex / Weinschel offers a selection of different attenuation ranges and frequency ranges to select from. These range from 0 to 10 dB in 1 dB steps up to 0 to 100 dB in 10 dB steps and frequency ranges from dc to 40 GHz. High volume fabrication techniques, including injection molding, stamping, broaching and thick film printing ensure a cost effective and uniform product.

What is the difference between insertion loss and incremental attenuation?

Step and variable attenuators have insertion loss and also incremental attenuation. Insertion loss is the loss through the attenuator when all cells are switched to zero dB. It is the residual loss of the device itself. Insertion loss usually increases with frequency reaching several dB at the higher frequencies and generally has very flat frequency response. Incremental attenuation is the attenuation values of the attenuators cells relative to the insertion loss. Since insertion loss is always present, the performance of a step or variable attenuator is always given as incremental attenuation relative to insertion loss. Insertion loss is considered part of the fixed performance of the system path in which the step or variable attenuator is located.

What types of variable attenuators does Weinschel offer?

There are several designs of continuously variable attenuator available in the marketplace: Piston, card, tee, and resistive center conductor. Weinschel offers only the Variable Card Attenuator Design.

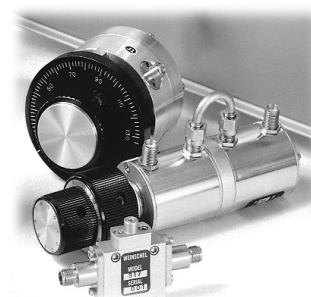

Weinschel's 940 series uses a card resistor on a disk with a movable coaxial contact (shown below) similar in nature to a potentiometer and provides an incremental range of 114 dB incremental range at 2 GHz and 60 dB at 4 GHz. Because the shunt film is connected to ground permanently, in order to achieve the extended attenuation range, the minimum loss of this type attenuator is higher (4 to 6 dB).

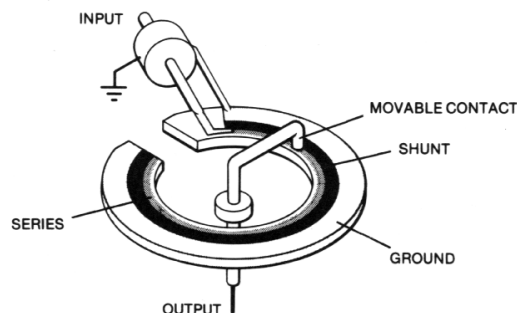

Model 940-60

dc to 4.0 GHz

Model 940-114

dc to 2.0 GHz

Precision Continuously Variable Attenuators

5 Watts

Choice of SMA or Type N Connectors

 **RoHS**



Features

- /// **Wide Variable Attenuation Range** - Variable attenuation range of 60 dB for Model 940-60 and 114 dB for Model 940-114, with minimum insertion loss at 6 dB.
- /// **Approximately Linear Calibrated Dial** - Direct reading dial individually calibrated in approximately linear 1 dB increments from 6 dB to full scale.
- /// **Rugged** - Designed to meet the environmental requirements of MIL-A-24215.
- /// **Long Life** - These variable attenuators offer a cycle life of up to 10,000 cycles. Optional models are also available to extend the life to 50,000 cycles.
- /// **Available Express Models:**
 - 940-60-11
 - 940-60-33
 - 940-60-33-1

Other models may be available for Express delivery.

Specifications

NOMINAL IMPEDANCE: 50 Ω

FREQUENCY RANGE: Model 940-60: dc to 4.0 GHz
Model 940-114: dc to 2.0 GHz

INCREMENTAL ATTENUATION RANGE:

Model 940-60: 60 dB
Model 940-114: 114 dB

MAXIMUM SWR:

Frequency Range (GHz)	SWR
dc - 1	1.50
1 - 2	1.60
2 - 3	1.70
3 - 4	1.80

DIRECT READING DIAL ACCURACY:

Model	ACCURACY*
940-60-XX	± 0.25 dB or 0.4% @ 2 GHz
940-114-XX	± 0.25 dB or 0.4% @ 1 GHz
940-60-XX-1	± 0.5 dB or 1% @ 2 GHz
940-114-XX-1	± 0.5 dB or 1% @ 1 GHz

*Whichever is greater.

CHARACTERISTIC INSERTION LOSS, RESIDUAL:

6 dB nominal

DIAL CALIBRATION (in 1 dB increments):

Model 940-60: 6 to 66 dB
Model 940-114: 6 to 120 dB

DIAL INCREMENTS: 1 dB

RESOLUTION OF SCALE:

Model 940-60: ~ 115°
Model 940-114: ~ 270°

CYCLE LIFE: A cycle consists of a rotation from minimum to maximum and back to minimum

Model 940-XX-XX : 10,000
Model 940-XX-XX-1: 50,000

PHASE SHIFT WITH CHANGE IN ATTENUATION:

1° per dB x f(GHz) maximum

POWER RATING: 5 watts average to 40°C ambient temperature, derated linearly to 0 watts @ 85°C. 500 watts peak (5 μsec pulse width; 0.5% duty cycle).

POWER COEFFICIENT: < 0.005 dB/dB/watt

TEMPERATURE COEFFICIENT: <0.001 dB/dB/°C

TEMPERATURE RANGE:

Operating: 0°C to +85°C
Nonoperating: -55°C to +125°C.

FREQUENCY SENSITIVITY:

Model 940-60: 0.05 x A x (F - Fd) dB
Model 940-114: 0.1 x A x (F - Fd) dB

A = Attenuation setting in dB, Fd = Dial cut frequency in GHz, F = Operation frequency in GHz

TEST DATA: Test frequency for Model 940-60 is 2 GHz and 1 GHz for 940-114. Test data is available at additional cost.

Variable Attenuators



Specifications-Con't

CONNECTOR: SMA or Type N connector per MIL-STD-348 interface dimensions - mate nondestructively with MIL-C-39012 connector.

Connector Options	INPUT (J1)	OUTPUT (J2)
11	SMA, Female	SMA, Female
12	SMA, Female	SMA, Male
22	SMA, Male	SMA, Male
33	N, Female	N, Female
34	N, Female	N, Male
44	N, Male	N, Male

CONSTRUCTION: Aluminum body and stainless steel connector; gold plated beryllium copper contacts. Knob is included with each unit.

WEIGHT: Net 1,570 g (3 lbs, 8 oz)

MODEL NUMBER DESCRIPTION:

Example:

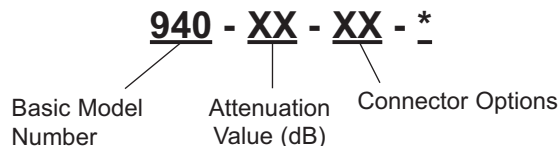

* Add -1 for long life version.

ACCESSORIES

ATTENUATOR STAND, MODEL 940 Z: This stand allows a user to easily mount any Model 940 for those bench applications.

PHYSICAL DIMENSIONS:

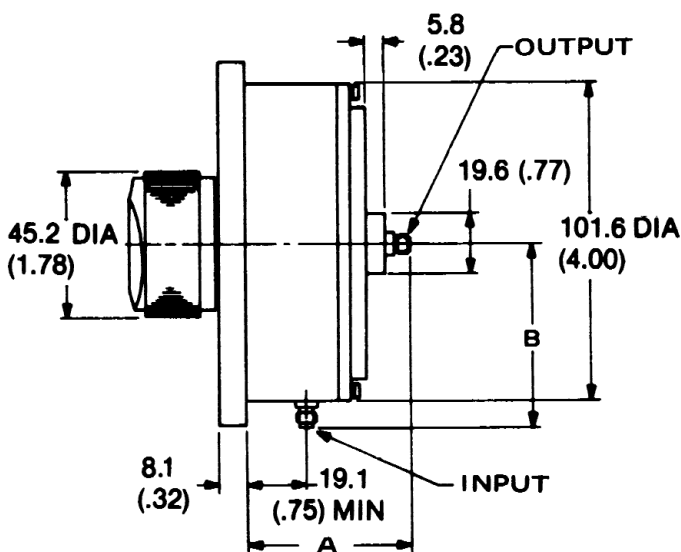
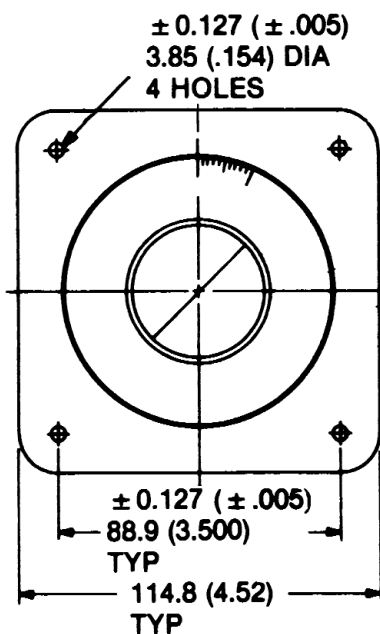

Model No.	DIM A	DIM B
940-XX-11	52.3 (2.06)	58.2 (2.29)
940-XX-12	55.6 (2.19)	58.2 (2.29)
940-XX-22	55.6 (2.19)	61.5 (2.42)
940-XX-33	61.0 (2.40)	68.1 (2.68)
940-XX-34	66.0 (2.60)	68.1 (2.68)
940-XX-44	66.0 (2.60)	71.9 (2.83)

NOTE:

1. All dimensions are given in mm (inches) and are maximum, unless otherwise specified.
2. Unit available with RoHS compliant materials, specify when ordering.

Model 3056 RF Manual Step Attenuator

dc to 3.0 GHz



1 Watt

SMA Connectors

RoHS



ATTENUATION ACCURACY (dB):

Frequency (GHz)	Accuracy
dc - 3.0	± 0.30 dB

MAXIMUM SWR & INSERTION LOSS:

Frequency (GHz)	SWR	Loss (dB)
dc-1.0	1.15	0.15
1.0-2.0	1.20	0.20
2.0-3.0	1.35	0.25

Features

- /// Rotational Stops Included
- /// Cost Effective OEM Design - Optimized for Wireless Communication System Applications.
- /// Custom Designs Available

Specifications

NOMINAL IMPEDANCE: 50 Ω
FREQUENCY RANGE: dc to 3.0 GHz
ATTENUATION RANGE/STEPS: 0-10 dB in 1.0 dB steps
TEMPERATURE RANGE: -20 °C to +85 °C
POWER RATING: 1 watt **average** @ 25°C ambient temperature, derated linearly to 0.25 watt @ 85°C. 100 watts **peak** (5 μsec pulse width; 0.5 % duty cycle).

CONNECTOR: SMA female connector per MIL-STD-348 interface dimensions - mate nondestructively with MIL-C-39012 connector.

SHAFT ROTATION: Clockwise for increasing attenuation

STEP ANGLE: 30.0°

CONSTRUCTION: Machined aluminum body. Knob is included with each unit.

WEIGHT: Net 110 g (4 oz)

NOTE: Minimum quantities apply. Contact factory or local sales representative for more information.

PHYSICAL DIMENSIONS:

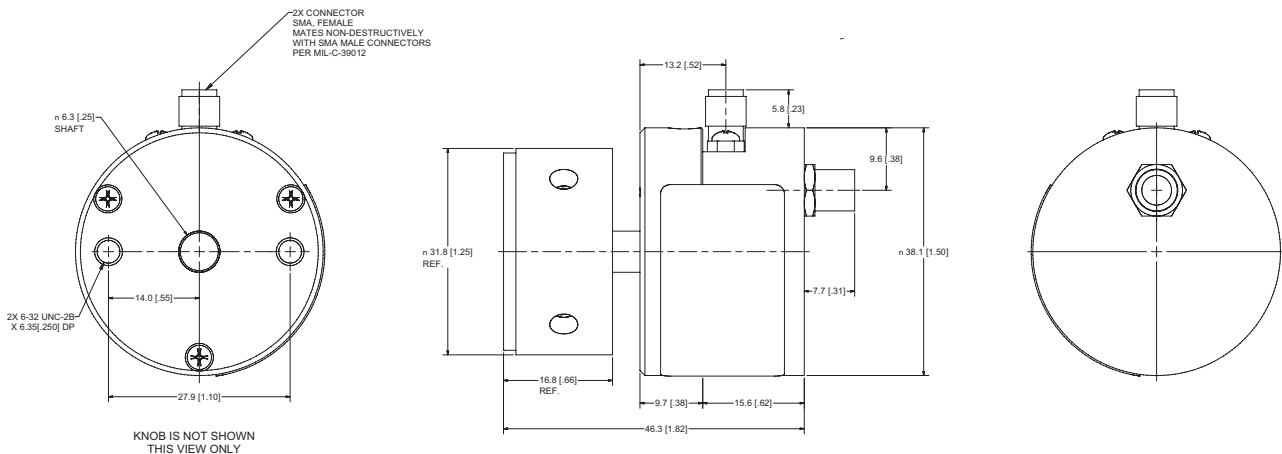

NOTE: All dimensions are given in mm (inches) and are maximum, unless otherwise specified.

Specifications-Con't

MAXIMUM SWR & ZERO INSERTION LOSS:

Model	Frequency (GHz)	SWR	Loss (dB)
3003	dc - 2.5	1.20	< 0.3
3006	dc - 1.25	1.20	< 0.2
3007	dc - 2.5	1.30	< 0.3
3010	dc - 2.5	1.35	< 0.7
3014	dc - 1.25	1.30	< 0.5

INCREMENTAL PHASE SHIFT: ~0.25° per dB x f(GHz)

CONSTRUCTION: Shafting and external hardware and connector shells: CRES Type 303, per ASTM-A582 passivated per QQ-P-35. Housing: AL ALLOY Gold Flash. Knob is included with each unit.

TEST DATA: Test data is available at additional cost.

WEIGHT: Single drum: Net 125 g (4.4 oz)
Dual drum: Net 201 g (9.9 oz)

SWITCHING LIFE: 1,000,000 steps

REPEATABILITY: ±0.1 dB over frequency range and rated life

ROTATION STOPS: Supplied on 10 dB step drums (not supplied on 1 dB drums).

MODEL NUMBER DESCRIPTION:

Example:

3010 - 100

Basic Model Number

Additional Options no longer available. Add -100 Only!

PHYSICAL DIMENSIONS:

SINGLE DRUM

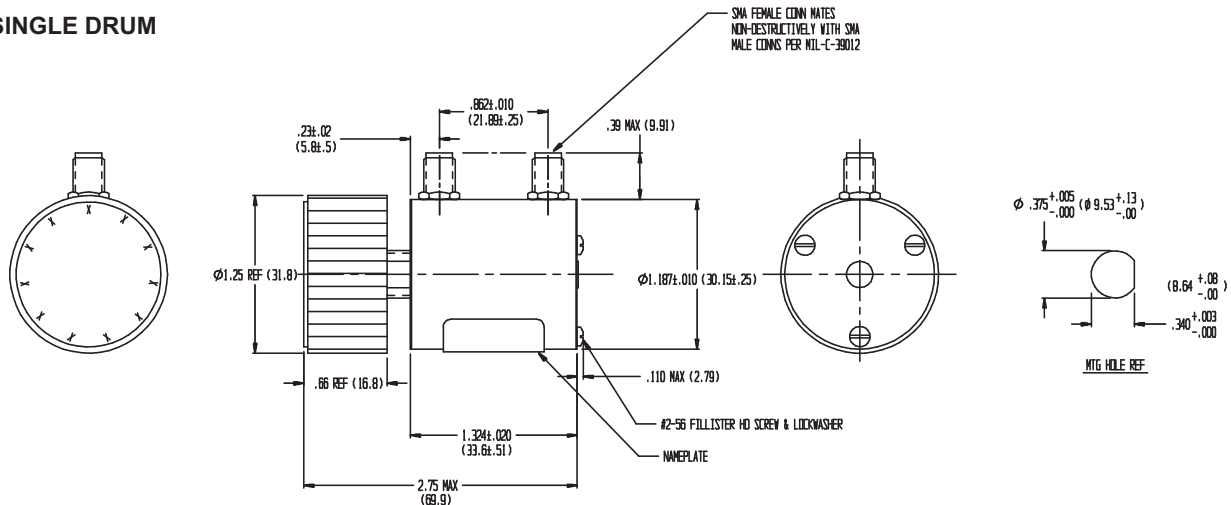

DUAL DRUM

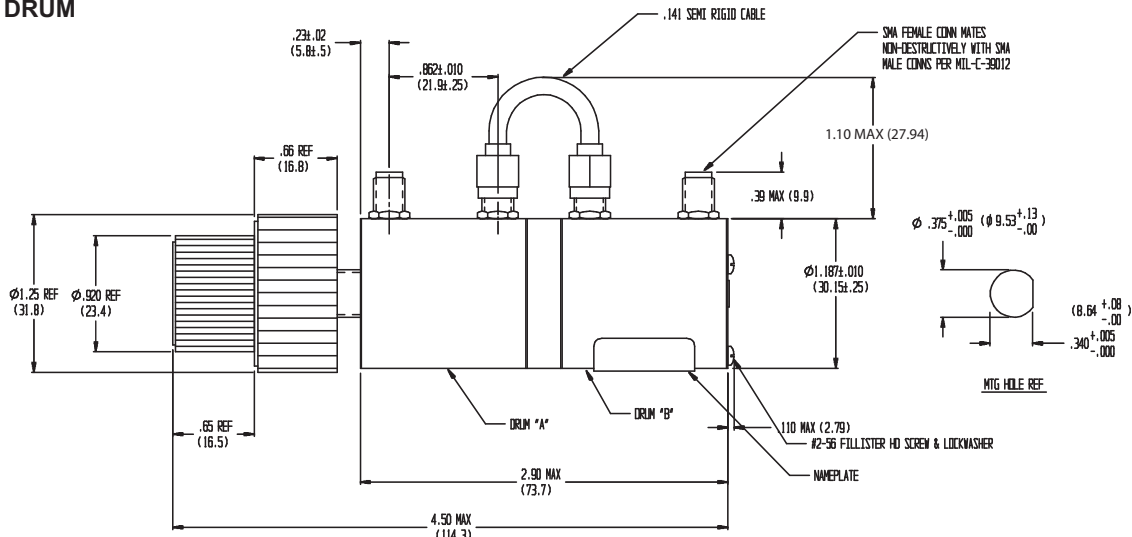

Variable Attenuators



Models 3053 & 3054 Manual Step, Ruggedized SMA Connectors

dc to 6.0 GHz
1 Watt



Specifications

NOMINAL IMPEDANCE: 50 Ω
 FREQUENCY RANGE: dc to 6.0 GHz
 INCREMENTAL ATTENUATION RANGE/STEPS:
 Model 3053: 0-10 dB in 1 dB steps
 Model 3054: 0-70 dB in 1 dB steps
 POWER COEFFICIENT: < 0.006 dB/dB/watt
 TEMPERATURE COEFFICIENT: 0.0004 dB/dB/ $^{\circ}\text{C}$
 TEMPERATURE RANGE:
 Operating: -40 $^{\circ}\text{C}$ to +65 $^{\circ}\text{C}$
 Non-Operating: -54 $^{\circ}\text{C}$ to +85 $^{\circ}\text{C}$

Features

- /// **High Reliability** - Repeatability better than 0.1 dB over frequency range and life. Weinschel patented detent mechanism, tested to 1,000,000 operations at +75 $^{\circ}\text{C}$, operates dependably even down to -40 $^{\circ}\text{C}$.
- /// **Product Uniformity** - High volume fabrication techniques, including injection molding, stamping, broaching and thick film printing ensure a cost effective and uniform product.
- /// **Low Frequency Sensitivity** - Typically 0.1 to 0.2 dB up to 2.5 GHz.
- /// **Shock Resistant** - 100% spring contact system withstands mechanical and thermal shock and eliminates the need for epoxy or solder.
- /// **Wide Selection** - Wide choice of attenuation ranges and increments in standard stock models. Single and dual drum configurations available.
- /// **Knob Included** - Knobs for both single and dual drum models are included with every attenuator. Characters are screened on the face of the knob insert which is coated with a clear layer of epoxy for protection.

Special Configurations

Some modifications to the basic configuration of the 3000 Series can be made during manufacturing. Examples of these special configurations are shafts having special lengths and ends; clockwise shaft rotation; modified mounting arrangements; and provisions for add-on items such as concentric potentiometer and ganged switches.

ATTENUATION ACCURACY:

Model	Accuracy
3053	± 0.3 dB
3054	± 0.3 dB or 2% (dc to 3 GHz) ± 0.3 dB or 3.5% (3 to 6 GHz)

POWER RATING: 1 watts **average** @ 25 $^{\circ}\text{C}$ ambient temperature, derated linearly to 0 watts @ 65 $^{\circ}\text{C}$. 100 watts **peak** (5 μsec pulse width; 0.5 % duty cycle).

CONNECTOR: SMA female connector per MIL-STD-348 interface dimensions - mate nondestructively with MIL-C-39012 connector.

SHAFT ROTATION: counter clockwise for increasing attenuation

STEP ANGLE: 32.7 $^{\circ}$

DRUM CONFIGURATIONS:

Single Drum: 3003, 3006, 3007, 3053
 Dual Drum: 3010, 3014, 3054

MAXIMUM SWR & ZERO INSERTION LOSS:

Model	Frequency (GHz)	SWR	Loss (dB)
3053	dc - 3.0	1.30	< 0.3
	3.0 - 6.0	1.40	< 0.7
3054	dc - 3.0	1.30	< 0.8
	3.0 - 6.0	1.55	< 1.3

Variable Attenuators



Models 9003, 9004, 9009, 9010 & 9011 dc to 18.0 GHz Manual Step, Ruggedized SMA Connectors 2 Watt

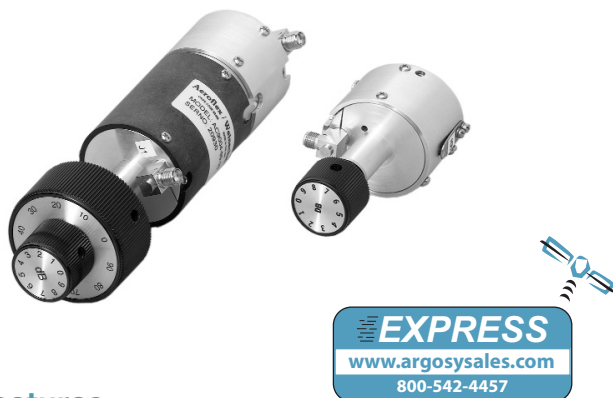

Features

- /// **Broadband** - Available in a choice of frequency ranges: dc to 4, dc to 8, dc to 12.4 and dc to 18 GHz.
- /// **Available Express Models:** AC-9003-69-31
AF-9003-9-12
AF-9003-69-31

Other models may be available for Express delivery.

- /// **Wide Choice of Attenuation Ranges** - A choice of five standard attenuation ranges is available: 0 to 9.0, 0 to 69 and 0 to 99 dB in 1 dB steps, and 0 to 60 and 0 to 90 dB in 10 dB steps.
- /// **Environmental** - Designed to meet most environmental requirements of MIL-A-24215 (Vibration, Shock, Relative Humidity to 95% and Altitude).
- /// **In-line Configuration** - Passivated stainless steel SMA connector are set parallel with control shaft (except units with right angle connector) to reduce volume for applications where space is critical. All models are bidirectional.
- /// **Precise Incremental Attenuation Accuracy** - Model 9000 series has flat frequency response and small deviation from nominal attenuation at all settings (e.g., deviation is only ± 2.5 dB at 99 dB setting at 18 GHz).
- /// **Excellent Repeatability and Long Switch Life.**
- /// **Custom Configurations Available Upon Request.**
- /// **Highly Accurate Detent Stepping** - Direct drive of attenuator drums eliminates gears and provides for excellent repeatability.
- /// **Safety Mechanical Stop** - A mechanical stop between maximum and 0 attenuation positions on all models except 0-9 dB unit is provided to prevent large power changes at attenuator output from damaging sensitive equipment.

Description

The Model 9000 series Step Attenuators are broadband miniature step attenuators that provide excellent performance characteristics suitable for use in high reliability 50 ohm systems and applications requiring extra-small components for the precision control of signal levels. The Model 9000 series can be used either as input or output attenuators in signal sources, receivers, field strength meters, spectrum analyzers, etc.

The SMA connector furnished on all models are available in either standard or right-angle configuration. The sex of front and rear connector is optional (refer to connector specification for specific combinations available). A knob(s), marked appropriately, is supplied with each unit.

Specifications

NOMINAL IMPEDANCE: 50 Ω

FREQUENCY RANGE (add Model No. Prefix to Designate Range):

All Models: dc to 4.0 GHz (AC)
dc to 18.0 GHz (AF)

Standard Incremental Attenuation Range:

Model 9009: 0 to 9 dB in 1 dB steps
Model 9003: 0 to 69 dB in 1 dB steps
Model 9004: 0 to 99 dB in 1 dB steps
Model 9010: 0 to 60 dB in 10 dB steps
Model 9011: 0 to 90 dB in 10 dB steps

MAXIMUM SWR:

Frequency Range (GHz)	9009, 9010 9011	9003 9004
dc - 4	1.25	1.35
dc - 18	1.60	1.75

POWER RATING: 2 watts **average** to 25°C ambient temperature, derated linearly to 1 watt @ 54°C. 200 watts **peak** (5 μ sec pulse width; 0.5% duty cycle)

POWER COEFFICIENT: < 0.005dB/dB/watt

TEMPERATURE COEFFICIENT: < 0.0004 dB/dB/°C

TEMPERATURE RANGE:

Operating: 0°C to +54°C
Nonoperating: -54°C to +54°C

Specifications--con't

TEST DATA: Insertion Loss data is supplied as follows. Other test data can be supplied at additional cost.

dc to 4 GHz: At 50 MHz and 4 GHz
 dc to 18 GHz: At 50 MHz, 4, 8, 12 and 18 GHz

INCREMENTAL PHASE SHIFT: ~0.5° per dB per GHz

REPEATABILITY: Better than 0.05 dB across frequency band for switch life

SWITCH LIFE: Over 1,000,000 steps

SHAFT ROTATION: Clockwise for increasing attenuation.

CONSTRUCTION:

Drum Assembly: Aluminum alloy
 Housing: Phenolic or aluminum
 Control Shaft: Stainless steel
 Connector: Stainless steel
 Knob: Supplied with control knob

INDEXING: 36°

DRUM CONFIGURATIONS:

Single Drum: 9009, 9010, 9011
 Dual Drum: 9003, 9004

MAXIMUM INSERTION LOSS (dB):

Frequency Range (GHz)	Model No.				
	9009	9003	9004	9010	9011
dc - 4	0.3	0.6	0.6	0.4	0.5
dc - 18	1.0	1.5	1.5	1.0	1.0

CONNECTOR: SMA connector per MIL-STD-348 interface dimensions - mate nondestructively with MIL-C-39012 connector. Front and rear SMA connector available in either standard or right-angle configuration, connector sex is optional as follows:

Connector Options	Type/Description
1	SMA, Female
2	SMA, Male*
3	SMA, Female, right-angle
4	SMA, Male, right-angle

*Standard male SMA connector not available as J1 connector.

WEIGHT:

9009	680 g (2.4 oz)
9010	160 g (5.7 oz)
9011	200 g (7.1 oz)
9003	260 g (9.0 oz)
9004	290 g (10.4 oz)

INCREMENTAL INSERTION LOSS (±dB):

Model Number	dB Range	Frequency Range (GHz)	
		dc-4	dc-18
9009	1-9	0.3	0.5
9003	1-9	0.3	0.5
	10-19	0.7	1.0
	20-29	0.9	1.2
	30-39	1.0	1.4
	40-49	1.1	1.5
	50-59	1.2	1.7
9004	60-69	1.3	1.9
	1-9	0.3	0.5
	10-19	0.7	1.0
	20-29	0.9	1.2
	30-39	1.0	1.4
	40-49	1.1	1.5
9010	50-59	1.2	1.7
	60-69	1.3	1.9
	70-79	1.4	2.1
	80-89	1.5	2.3
	90-99	1.6	2.5
	9011	10	0.3
20		0.3	1.0
30		0.4	1.0
40		0.5	1.2
50		0.7	1.5
60		0.8	1.8
9011	70	0.9	2.1
	80	1.0	2.3
	90	1.2	2.5

NA=Model no longer available.

MODEL NUMBER DESCRIPTION:

Example:

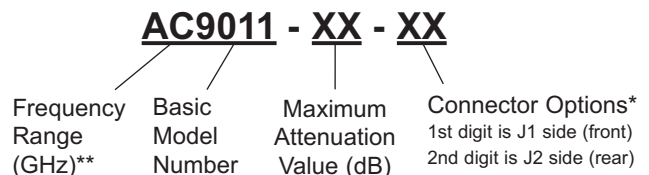

** Frequency Range
 dc-4.0 GHz (AC)
 dc-8.0 GHz (AD)
 dc-12.4 GHz (AE)
 dc-18.0 GHz (AF)

Available Models
 AC9003, AC9004, AC9009, AC9010, AC9011
 No longer available, order AF as replacement
 No longer available, order AF as replacement
 AF9003, AF9004, AF9009, AF9010, AF9011

Variable Attenuators



PHYSICAL DIMENSIONS:

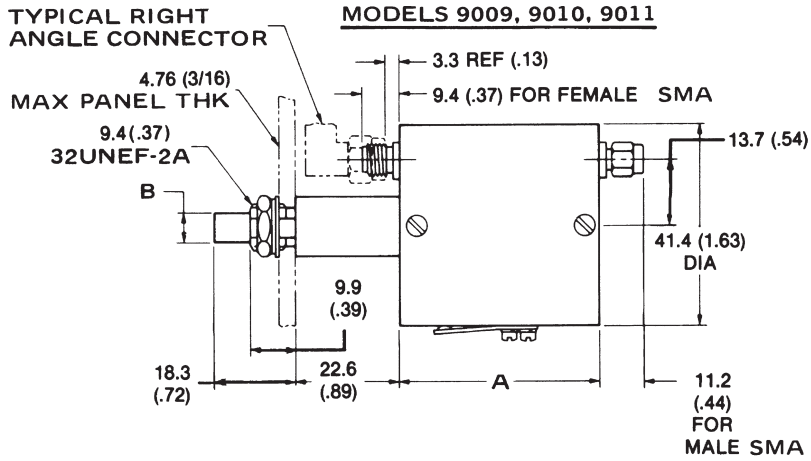

RIGHT ANGLE FEMALE SMA

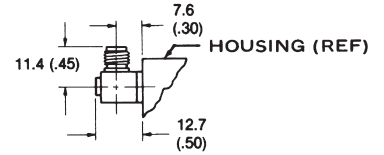

RIGHT ANGLE MALE SMA

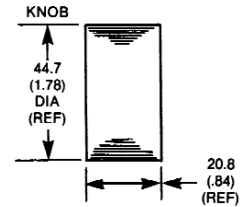
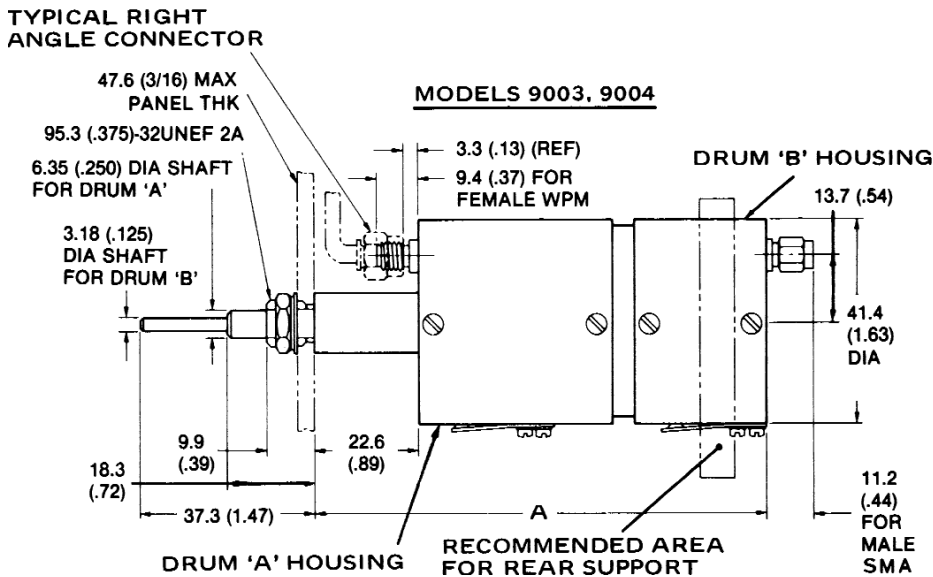
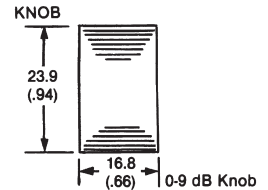
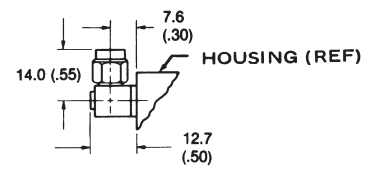

MOUNTING HOLE

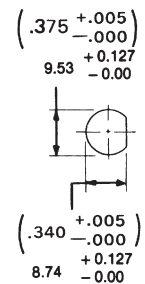

Model No.	DIM A	DIM B
9003	96.3 (3.79)	---
9004	106.4 (4.19)	---
9009	28.7 (1.13)	3.25 (0.125)
9010	41.4 (1.63)	6.35 (0.250)
9011	51.6 (2.03)	6.35 (0.250)

NOTE: All dimensions are given in mm (inches) and are maximum, unless otherwise specified.

Models 115A thru 119A Manual Step Attenuators

dc to 18.0 GHz
2 Watt

Choice of Type N or SMA Connectors



Features

- /// **Safety Mechanical Stop** - A mechanical stop between maximum and 0 attenuation positions on all models prevents damage to the mechanical drive as well as preventing large power changes that could cause damage to sensitive equipment.
- /// **Choice of Attenuation Ranges** - Five standard attenuation ranges are available: 0-9 dB, 0-69 dB, and 0-99 dB in 1 dB steps, and 0-60 dB and 0-90 dB in 10 dB steps.
- /// **Broadband** - All models are available in a choice of 2 frequency ranges: dc-4 and dc-18 GHz.
- /// **Right-Angle Drive** - The center conductor of the connector is perpendicular to the control shaft, offering greater flexibility of applications: panel mounting or bench setup. All models are bidirectional.
- /// **Custom Configurations Available Upon Request.**
- /// **Low Deviation from Nominal Value** - These Mini Step Attenuators have flat frequency response over specified bands and excellent attenuation accuracy. Deviation from nominal value is low at all settings.
- /// **Excellent Repeatability and Long Life Switch** - Repeatability is better than 0.05 dB to 18.0 GHz for over 1,000,000 switchings of the drum.

Description

The Aeroflex / Weinschel Models 115A through 119A are a series of broadband, step attenuators in a right-angle drive configuration, where the center conductor of the connector is perpendicular to the control shaft. They feature excellent performance characteristics suitable for use in high reliability 50 ohm systems and applications requiring extra-small components for the precision control of power in discrete steps. They can be used either as input or output attenuators in signal sources, receivers, field strength meters, spectrum analyzers, etc.

Specifications

NOMINAL IMPEDANCE: 50 Ω

FREQUENCY RANGE (add Model No. Prefix to Designate Range):

All Models: dc to 4.0 GHz (AC)
dc to 18.0 GHz (AF)

STANDARD INCREMENTAL ATTENUATION RANGE:

Model 115A: 0 to 9 dB in 1 dB steps
Model 116A: 0 to 60 dB in 10 dB steps
Model 117A: 0 to 69 dB in 1 dB steps
Model 118A: 0 to 90 dB in 10 dB steps
Model 119A: 0 to 99 dB in 1 dB steps

MAXIMUM SWR (Models 117A & 119A):

Frequency Range (GHz)	117A & 119A	115A, 116A & 118A
dc - 4	1.35	1.25
4 - 12.4	1.50	1.60
12.4 - 18.0	1.70	1.60

POWER RATING: 2 watts **average** to 25°C ambient temperature, derated linearly to 1 watt @ 54°C. 200 watts **peak** (5 μ sec pulse width; 0.5% duty cycle)

POWER COEFFICIENT: < 0.005/dB/dB/watt

TEMPERATURE COEFFICIENT: < 0.0004/dB/dB/°C

TEMPERATURE RANGE: Operating: 0°C to +54°C
Nonoperating: -54°C to +54°C

INCREMENTAL PHASE SHIFT: ~0.5° per dB x f(GHz)

REPEATABILITY: Better than 0.05 dB across frequency band for switch life.

SWITCH LIFE: Over 1,000,000 steps

INDEXING: 36°

MAXIMUM INSERTION LOSS (dB):

Model Number	CONN Type	Frequency Range (GHz)	
		dc-4	dc-18
115A	N	0.3	0.7
	SMA	0.3	1.0
116A	N	0.3	0.7
	SMA	0.4	1.0
117A	N	0.5	1.2
	SMA	0.6	1.5
118A	N	0.4	0.8
	SMA	0.5	1.0
119A	N	0.5	1.2
	SMA	0.6	1.5

Variable Attenuators



Specifications (Con't):

TEST DATA: Insertion Loss data is supplied as follows.
Other test data can be supplied at additional cost.
dc to 4 GHz: At 50 MHz and 4 GHz
dc to 18 GHz: At 50 MHz, 4, 8, 12 and 18 GHz

RELATIVE HUMIDITY: 95%

ALTITUDE: to 10,000 ft.

SHOCK (non-operating): 8 g's, 100 ms, 1/2 sine

DRUM CONFIGURATIONS:

Single Drum: 115A, 116A, 118A

Dual Drum: 117A, 119A

VIBRATION (non-operating):

5 to 8 cps, 0.20 inch double amplitude

8 to 15 cps, 0.10 inch double amplitude

15 to 55 cps, 0.36 inch double amplitude

Supported rigidly front and back

SHAFT ROTATION: Clockwise for increasing attenuation

CONSTRUCTION:

Materials: Housing: aluminum alloy, clear irridite,
MIL-C-5541.

Dust Cover: Painted aluminum alloy

Drum: Aluminum alloy

Shaft: Passivated stainless steel

Connector: Stainless steel and beryllium
copper contacts.

CONNECTOR: SMA and Type N connectors per MIL-STD-348 interface dimensions - mate nondestructively with MIL-C-39012 connector. Connector sex is optional as follows:

Connector Options	Type/Description
1	SMA, Female
2	SMA, Male
3	Type N, Female
4	Type N, Male

WEIGHT:

115A	340 g (12 oz)
116A	340 g (12 oz)
117A	760 g (27 oz)
118A	450 g (16 oz)
119A	880 g (31 oz)

INCREMENTAL INSERTION LOSS (±dB):

Model Number	dB Range	Frequency Range (GHz)	
		dc-4	dc-18
115A	1-9	0.3	0.5
117A	1-9	0.3	0.5
	10-19	0.7	1.0
	20-29	0.9	1.2
	30-39	1.0	1.4
	40-49	1.1	1.5
	50-59	1.2	1.7
119A	60-69	1.3	1.9
	1-9	0.3	0.5
	10-19	0.7	1.0
	20-29	0.9	1.2
	30-39	1.0	1.4
	40-49	1.1	1.5
	50-59	1.2	1.7
	60-69	1.3	1.9
	70-79	1.4	2.1
	80-89	1.5	2.3
90-99	1.6	2.5	
116A	10	0.3	1.0
	20	0.3	1.0
	30	0.4	1.0
	40	0.5	1.2
	50	0.7	1.5
	60	0.8	1.8
118A	10	0.3	1.0
	20	0.3	1.0
	30	0.4	1.0
	40	0.5	1.2
	50	0.7	1.5
	60	0.8	1.8
	70	0.9	2.1
80	1.0	2.3	
90	1.2	2.5	

MODEL NUMBER DESCRIPTION:

Example:

AC116A - XX - XX

Frequency Range (GHz)	Basic Model Number	Maximum Attenuation Value (dB)	Connector Options* 1st digit is J1 side (left) 2nd digit is J2 side (right)

PHYSICAL DIMENSIONS:

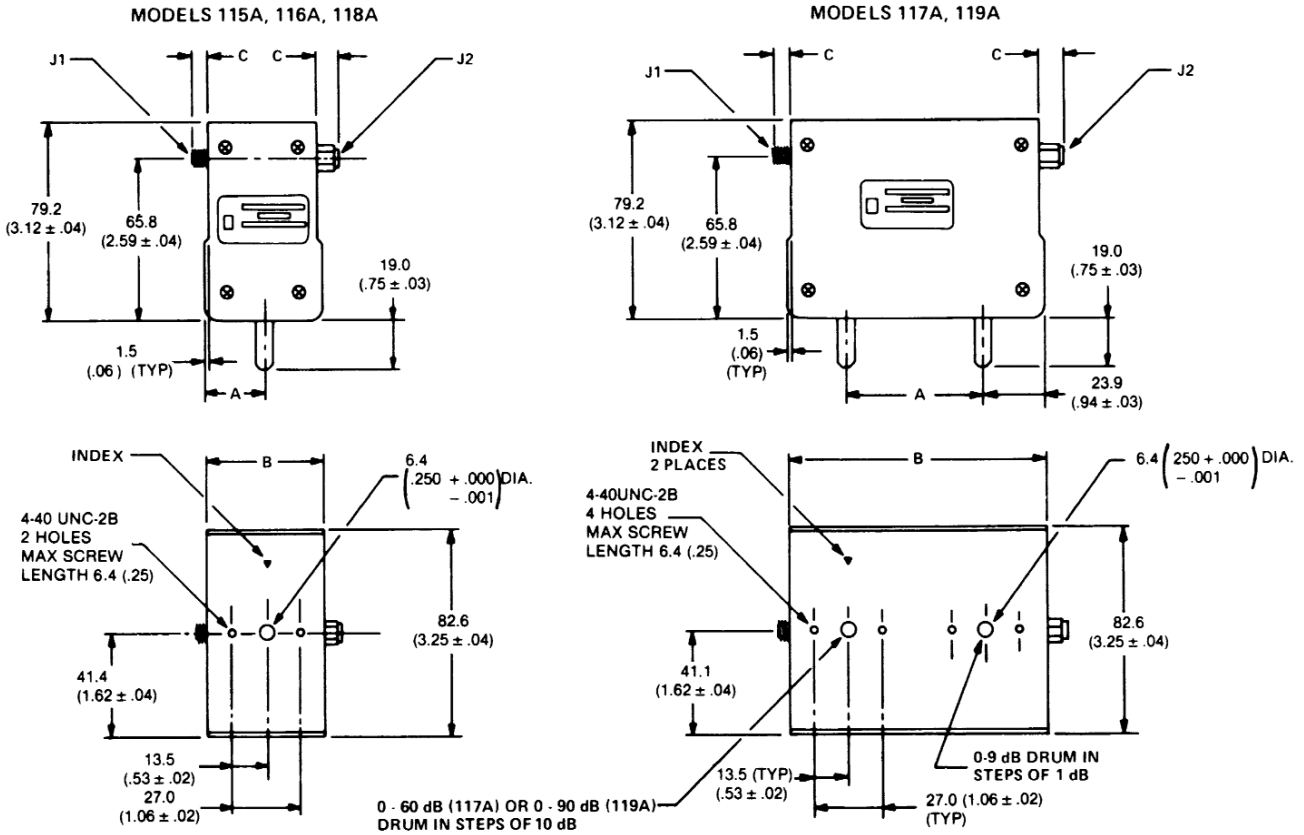

Model No.	DIM A	DIM B
119A	58.7 (2.31)	111.3 (4.38)
118A	29.0 (1.14)	57.7 (2.27)
117A	54.0 (2.11)	101.1 (3.98)
116A	23.9 (0.94)	47.5 (1.87)
115A	23.9 (0.94)	47.5 (1.87)

CONN Type	DIM C
Type N, Male	20.6 (0.81)
Type N, Female	18.3 (0.72)
SMA, Male	9.4 (0.37)
SMA, Female	7.9 (0.31)

NOTE: All dimensions are given in mm (inches) and are maximum, unless otherwise specified.

Variable Attenuators



Model 9012 Manual Step, SMK Connectors

dc to 26.5 GHz
2 Watts



Features

- /// Choice of Attenuation Ranges and Step Sizes.
- /// Excellent Repeatability.
- /// Custom Configurations Available Upon Request.
- /// Highly Accurate Detent Stepping
- /// Ruggedized Connector - Injection molded to provide consistent interface dimensions.

Specifications

NOMINAL IMPEDANCE: 50 Ω

FREQUENCY RANGE: dc to 26.5 GHz

INCREMENTAL ATTENUATION RANGE/STEPS:

Model 9012-9: 0-9 dB in 1 dB steps

Model 9012-70: 0-70 dB in 10 dB steps

INCREMENTAL ATTENUATION ACCURACY:

Model No.	Accuracy
9012-9	± 0.5 dB
9012-70	± 1.0 dB or 2%

MAXIMUM SWR:

Frequency Range (GHz)	9012
dc - 18	1.40
18 - 26.5	1.50

MAXIMUM ZERO INSERTION LOSS (±dB):

Frequency Range (GHz)	9012
dc - 18	1.00
18 - 26.5	1.50

POWER RATING: 2 watts **average** to 25°C ambient temperature, derated linearly to 1 watt @ 54°C. 200 watts **peak** (5 μsec pulse width; 0.5% duty cycle)

POWER COEFFICIENT: < 0.005 dB/dB/watt

TEMPERATURE COEFFICIENT: < 0.0004 dB/dB/°C

TEMPERATURE RANGE:

Operating: 0°C to + 54°C

Nonoperating: -54°C to + 54°C

REPEATABILITY: ±0.5 dB to 60 dB

TEST DATA: Insertion loss and SWR data supplied at selected frequencies between 50 MHz and 26.5/40 GHz. Other test data can be provided at additional cost.

CONNECTOR: 2.92mm female connector - mate nondestructively with SMA connector per MIL-C-39012, SMK, 3.5mm, and other 2.92mm connector.

CONSTRUCTION: Stainless steel connector; gold plated beryllium copper contacts. Knob is included with each unit.

WEIGHT: Net 270 g (9.6 oz)

PHYSICAL DIMENSIONS:

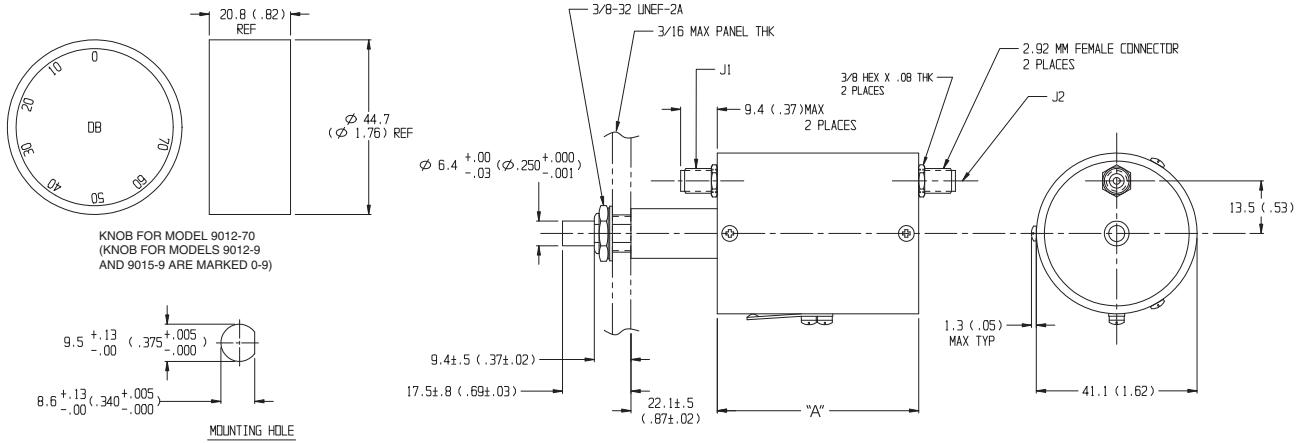

NOTE: All dimensions are given in mm (inches) and are maximum, unless otherwise specified.

Model No.	DIM A
9012-9, 9012-70	51.56 (2.03)

Power Splitters & Dividers



- /// Broadband Frequency Range - dc to 40 GHz
- /// Widest Selection of connector types & Frequency
- /// **Express** shipment available on select models.
- /// 4-Way Designs Available
- /// High Quality Construction & Connectors
- /// Stable - Low temperature and power coefficients ensure operating stability.
- /// Custom Designs Available on Request - Just contact us with your special requirement...
 - Broadband High Power
 - Low SWR\Return Loss
 - Unique Packaging

General Information

In this section of the catalog, each Resistive Power Splitter/Divider & Directional Coupler is outlined utilizing individual data sheets containing product features, specifications and outline drawings. These data sheets are preceded by a quick reference guide to help you select the product(s) that fits your needs. The page number for each product data sheet is given in the quick reference guide.



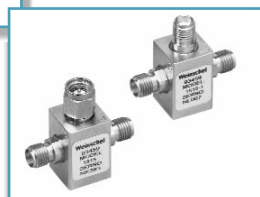

Aeroflex / Weinschel offers a comprehensive product line of Power Dividers, and Power Splitters. Many of these standard products were designed for particularly demanding broadband requirements, SWR, and high power system applications. As with the development of all Aeroflex / Weinschel products, high performance at competitive prices is of paramount importance.

NOTE: **EXPRESS** Shipment available via www.argosysales.com or 800-542-4457. Check with distributor for current products and stocking quantities.









Resistive Power Splitters...dc-40.0 GHz



Model Number	Frequency Range (GHz)	Connector Type	Maximum SWR		Maximum Insertion Loss (dB)	Amplitude Tracking (dB MAX)	Phase Tracking (\pm°)	Average Input Power (W)	Page No.	
			INPUT	OUTPUT						
♦ 1507R	dc-4.0	2.92mm (f) all	1.15	1.25	6.5	<0.20	<4.0	1	154	
♦ 1579	dc-26.5	3.5mm (f) al	1.50	1.45	8.5	0.40	5.0	0.5	155	
♦ 1593	dc-26.5	3.5mm (f) al	1.25	1.35	8.5	0.25	4.0	0.5	157	
♦ 1534	dc-40.0	2.92mm (f) all	160	160	10.5	0.50	4.0	1.0	158	
♦ 1870A	dc-18.0	N (f) all	1.15	1.15	7.5	0.20	2.0	1	156	

Resistive Power Dividers...dc-40.0 GHz, 2-Way & 4-Way



Model Number	Frequency Range (GHz)	Connector Type	Maximum SWR		Maximum Insertion Loss (dB)	Amplitude Tracking (dB MAX)	Phase Tracking (\pm°)	Average Input Power (W)	Page No.	
			INPUT	OUTPUT						
♦ 1506A	dc-18.0	N(m) IN (f) OUT	1.35	1.35	7.5	0.50	2.0	1	161	
1515	dc-18.0	SMA (m) IN (f) OUT	1.35	1.35	7.5	0.50	5.0	1	160	
♦ 1515-1		SMA (f) all								
♦ 1549R	dc-4.0	SMA (f) all	1.25	1.25	6	<0.20	<4.0	1	159	
♦ 1550A (4-way)	dc-3.0	SMA (f) all	1.25	1.25	13.5	0.50	10.0	1	164	
1575	dc-40.0	2.92mm (f) all	1.70	1.70	8.5	<0.25-0.50*	2.0-5.0*	1	163	
♦ 1580	dc-26.5	3.5mm (m) IN (f) OUT	1.25	1.25	8.5	0.20	8.0**	1	162	
1580-1		3.5mm (f) all								
♦ 1594 (4-way)	dc-18.0	3.5mm (f) all	1.30	1.30	14.5	2.50	50.0	2	164	

(f) denotes female & (m) denotes male.

* Varies with Frequency.

** Maximum between any two output ports

- ♦ EXPRESS Shipment available via www.argosysales.com or 800-542-4457.
Note: Other models may also be available from Express delivery.

Frequently Asked Questions about Power Splitters & Dividers. . .

What Types of power splitters and dividers does Weinschel offer?

Weinschel offers a variety of broadband (dc-40 GHz) resistive power splitters and dividers with Type N, SMA, 3.5mm, 2.92mm connector options. Power Dividers are available in 2 and 4 way configurations.

How does a resistive power splitter work?

Our resistive power splitters are intended for applications in which one of the two outputs are included in a leveling loop or used as a reference in a ratio measurement system, for the purpose of providing an output signal whose source impedance is essentially matched to 50 ohms. A basic design consists of three ports with a resistor on each of the two output ports, and is a unidirectional device.

What are some applications for a resistive power splitter?

Resistive power splitters provide exceptional amplitude tracking and a very low equivalent output SWR over very broad frequency ranges. They are used in applications in which one of the two outputs is included in a leveling loop or as a reference in a ratio systems such as:

- /// A dual channel insertion loss measuring system where the resistive power splitter provides reference and a signal channel.
- /// A precision power source where a power meter of known characteristics is used, either by ratio or leveling to provide a calibrated output.
- /// Provide a sampled output used for leveling a signal source - for instance in single channel attenuation measurements.

What applications use resistive power dividers?

- /// Broadband independent signal sampling - used in systems to simultaneously measure two different characteristics of one signal such as frequency and power.
- /// Distribution of a low power signals to two or more antennas.
- /// Laboratory measurements where a reference signal exactly tracking the reference signal is required.
- /// Resistive power dividers can be used as power combiners because they are bidirectional.

When do I use a power splitter or divider?

In simple terms many are confused as to the difference between power splitters and power dividers. Here is some basic information that we hope will help.

How do I determine the Insertion Loss for a Power Divider or Power Splitter?

For Resistive power divider: Isolation = Insertion Loss
 For Resistive power splitter: Isolation = Twice the Insertion Loss

Power splitters are only used in a ratio systems or leveling loop.

- /// Power splitters can never be used to combined power. They are unidirectional.
- /// A basic power splitter has two resistors and three ports. Power dividers should not be used in ratio and leveling loop application because a mismatch condition of nominally 3:1 would exist.
- /// Power dividers can be used as power combiners because they are bi-directional. Power dividers can be used in a system to simultaneously measure two different characteristics of one signal such as frequency and attenuation, power splitters can not.
- /// A basic power divider has three resistors and three ports. A simple description of the circuit shows that any one of the three ports has 50 ohm input impedance when the others are terminated in 50 ohms. The insertion loss between any two ports is 6 dB.



What is a Resistive Power Divider?

An equivalent circuit of the resistive divider is shown below. A simple analysis of this circuit will demonstrate that any one of the three ports has a 50 ohm input impedance when the other two are terminated in 50 ohms, and that the insertion loss between any two ports is 6 dB. A microwave network of this type consists of a symmetrical resistive film deposited on a ceramic substrate having three conducting contacts, each connected to the center conductor of a coaxial connector. Resistive dividers provide well-matched signals of essentially equal magnitude and phase over a very broad band as opposed to the reactive and hybrid types which employ frequency limitive techniques. The resistive divider is intended for applications where the output signals are used independently, such as the simultaneous monitoring of power and frequency.

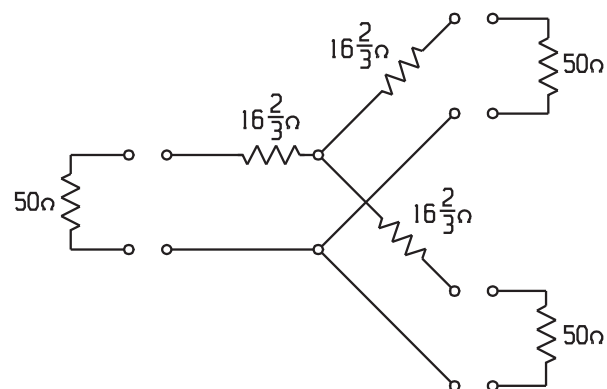

Model 1507R Broadband Resistive Power Splitter (Matching), SMK Connectors

dc to 4.0 GHz
1 Watt

RoHS

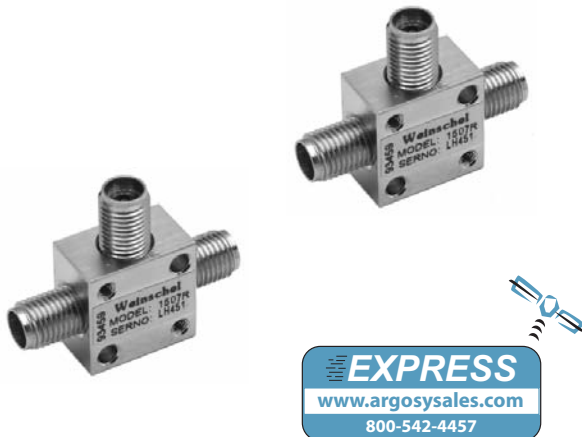

MAXIMUM SWR:

Frequency (GHz)	Output*	Input
dc -4	1.15	1.25

*Equivalent output SWR when used in a leveling or ratio system.

TEMPERATURE RANGE: -55 °C to +125 °C

CONNECTORS: Female SMK (2.92 mm, SMA compatible) connectors all ports--mate nondestructively with other SMA, 2.92mm and 3.5mm connectors.

WEIGHT: 25 g (0.9 oz) maximum

PHYSICAL DIMENSIONS:

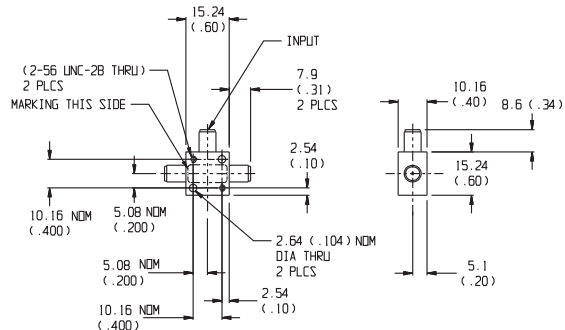

NOTE: All dimensions are given in mm (inches) and are maximum, unless otherwise specified.

Features

These resistive power splitters are intended for RF and wireless applications in which one of the two outputs is included in a leveling loop or is used as a reference in a ratio system, for the purpose of providing an output signal whose source impedance is essentially matched to 50Ω. Some examples are:

- /// A dual channel insertion loss measuring system (ratio).
- /// A parallel IF substitution insertion loss measuring system (ratio or ALC loop).
- /// A precision power source (ratio or ALC loop).

Specifications

NOMINAL IMPEDANCE: 50 Ω

FREQUENCY RANGE: dc to 4.0 GHz

INSERTION LOSS: 6 dB nominal, 6.5 dB maximum
(Between input and either output)

MAXIMUM INPUT POWER: 1.0 watt CW (Input connector only)

AMPLITUDE & PHASE TRACKING (Maximum):

Frequency (GHz)	Tracking	
	Amplitude	Phase
dc - 4.0	<0.2 dB	<4°

Power Splitters & Dividers



Model 1579 Broadband Resistive Power Splitter (Matching), 3.5mm Connectors

dc to 26.5 GHz
0.5 Watts

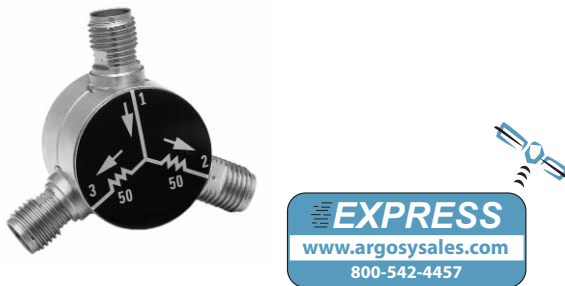

EQUIVALENT OUTPUT SWR (Port 2 & 3):

Frequency (GHz)	Maximum SWR
dc - 18	1.25
18 - 26.5	1.45

*When used in a leveling or ratio system.

Features

These resistive power splitters are intended for RF and wireless applications in which one of the two outputs is included in a leveling loop or is used as a reference in a ratio system, for the purpose of providing an output signal whose source impedance is essentially matched to 50Ω. Some examples are:

- /// A dual channel insertion loss measuring system (ratio).
- /// A parallel IF substitution insertion loss measuring system (ratio or ALC loop).
- /// A precision power source (ratio or ALC loop).

Specifications

NOMINAL IMPEDANCE: 50 Ω

FREQUENCY RANGE: dc to 26.5 GHz

INSERTION LOSS: 6 dB nominal, 8.5 dB maximum
(Between input and either output)

MAXIMUM INPUT POWER: 0.5 watts CW (Input Connector only)

OUTPUT TRACKING (Between Ports):

Frequency (GHz)	Tracking (maximum dB)
dc - 4	0.15
4 - 8	0.20
8 - 18	0.30
18 - 26.5	0.40

MAXIMUM INPUT SWR:

Frequency (GHz)	Maximum SWR
dc - 26.5	1.50

PHASE TRACKING: ±5° nominal between output ports

POWER COEFFICIENT: < 0.005 dB/dB/watt

TEMPERATURE COEFFICIENT: < 0.0004 dB/dB/°C

TEMPERATURE RANGE: -55°C to +125°C

TEST DATA: Insertion Loss, SWR, and Tracking measurements performed across the frequency band. Test data available at additional cost.

CONNECTORS: Female 3.5mm connectors all ports--mate nondestructively with SMA, 2.92mm and other 3.5mm connectors.

CONSTRUCTION: Gold plated brass body; stainless steel connectors; gold plated beryllium copper contacts.

WEIGHT: 30 g (1 oz) maximum

PHYSICAL DIMENSIONS:

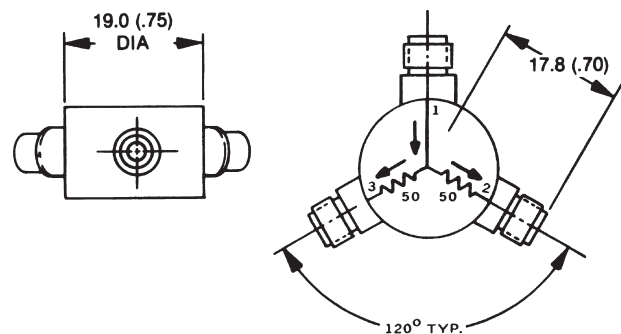

NOTE: All dimensions are given in mm (inches) and are maximum, unless otherwise specified.

Model 1870A Broadband Resistive Power Splitter (Matching), Precision N Connectors

dc to 18.0 GHz
1 Watt

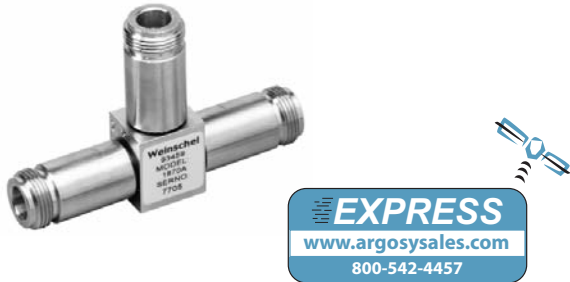

Features

These resistive power splitters are intended for RF and wireless applications in which one of the two outputs is included in a leveling loop or is used as a reference in a ratio system, for the purpose of providing an output signal whose source impedance is essentially matched to 50Ω. Some examples are:

- /// A dual channel insertion loss measuring system (ratio).
- /// A parallel IF substitution insertion loss measuring system (ratio or ALC loop).
- /// A precision power source (ratio or ALC loop).

Specifications

NOMINAL IMPEDANCE: 50 Ω
FREQUENCY RANGE: dc to 18.0 GHz
INSERTION LOSS: 6 dB nominal, 7.5 dB maximum
 (Between Input and either output).
MAXIMUM INPUT POWER: 1 watt average, 1 kilowatt peak
 (Input connector only)

OUTPUT TRACKING (Between Ports):

Frequency (GHz)	Tracking (maximum dB)
dc - 8	0.15
8 -18	0.20

PHASE TRACKING: ±2° nominal between output ports
POWER COEFFICIENT: < 0.005 dB/dB/watt
TEMPERATURE COEFFICIENT: <0.0004 dB/dB/°C
TEMPERATURE RANGE: -55°C to +85°C
CONSTRUCTION: Nickel plated brass body; stainless steel connectors; gold plated beryllium copper contacts.

MAXIMUM INPUT SWR:

Frequency (GHz)	Maximum SWR
dc - 18	1.30

EQUIVALENT OUTPUT SWR (Port 2 & 3):

Frequency (GHz)	Maximum SWR
dc - 2	1.05
2 - 4	1.07
4 - 8	1.10
8 - 18	1.15

* When used in a leveling or ratio system.

TEST DATA: Insertion Loss, SWR, and Tracking measurements performed across the frequency band. Test data available at additional cost.

CONNECTORS: Type N female connectors per MIL-STD-348 interface dimensions - mate nondestructively with MIL-C-39012 connectors.

WEIGHT: Net 170 g (6 oz)

PHYSICAL DIMENSIONS:

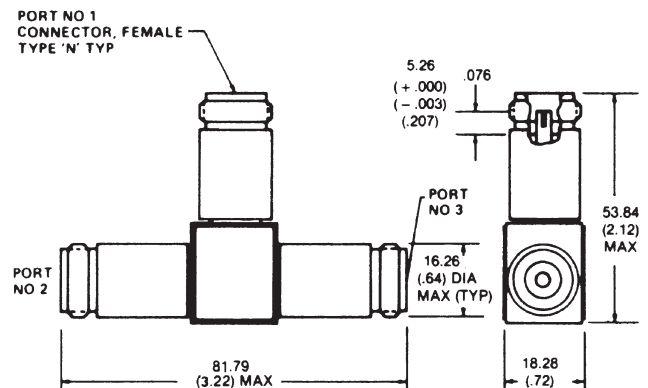

NOTE: All dimensions are given in mm (inches) and are maximum, unless otherwise specified.

Power Splitters & Dividers



Model 1593 Broadband Resistive Power Splitter (Matching), Subminiature, 3.5mm Connectors

dc to 26.5 GHz
1 Watt

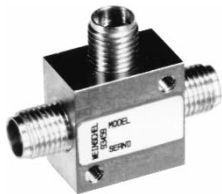

Features

These resistive power splitters are intended for RF and wireless applications in which one of the two outputs is included in a leveling loop or is used as a reference in a ratio system, for the purpose of providing an output signal whose source impedance is essentially matched to 50Ω. Some examples are:

- /// A dual channel insertion loss measuring system (ratio).
- /// A parallel IF substitution insertion loss measuring system (ratio or ALC loop).
- /// A precision power source (ratio or ALC loop).

Specifications

NOMINAL IMPEDANCE: 50 Ω
FREQUENCY RANGE: dc to 26.5 GHz
INSERTION LOSS: 6 dB nominal, 8.5 dB maximum
 (Between input and either output)
MAXIMUM INPUT POWER: 1.0 watts CW (Input Connector only)

AMPLITUDE & PHASE TRACKING (Maximum):

Frequency (GHz)	Tracking	
	Amplitude	Phase
dc - 26.5	<0.25 dB	<4°

MAXIMUM INPUT SWR:

Frequency (GHz)	Maximum SWR
dc - 26.5	1.25

EQUIVALENT OUTPUT SWR (Port 2 & 3):

Frequency (GHz)	Maximum SWR
dc - 18	1.25
18 - 26.5	1.35

*When used in a leveling or ration system.

TEMPERATURE RANGE:

Operating: -55°C to +85°C
 Storage: -55°C to +125°C

TEST DATA: Insertion Loss, SWR, and Tracking measurements performed across the frequency band. Test data available at additional cost.

CONNECTORS: Female 3.5mm connectors all ports --mate nondestructively with SMA, 2.92mm and other 3.5mm connectors.

WEIGHT: 25 g (0.9 oz) maximum

PHYSICAL DIMENSIONS:

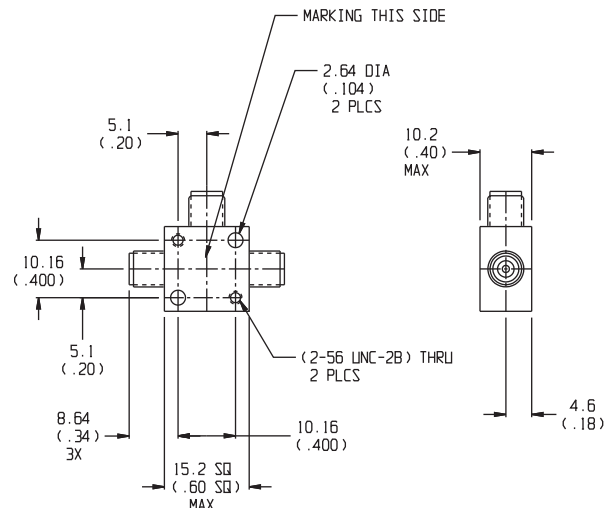

NOTE: All dimensions are given in mm (inches) and are maximum, unless otherwise specified.

Model 1534 Broadband Resistive Power Splitter (Matching), Subminiature, SMK Connectors

dc to 40.0 GHz
1 Watt

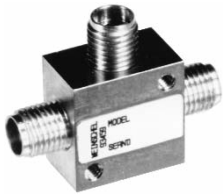

Features

These resistive power splitters are intended for RF and wireless applications in which one of the two outputs is included in a leveling loop or is used as a reference in a ratio system, for the purpose of providing an output signal whose source impedance is essentially matched to 50Ω. Some examples are:

- /// A dual-channel insertion loss measuring system where the resistive power splitter provides a reference and a signal channel for ratio meter.
- /// A parallel IF substitution insertion loss measuring system where the resistive power splitter provides a sampled output for leveling the signal source.
- /// A precision power source where a power meter of known characteristics is used, either by ratio or leveling to provide a calibrated output.

Specifications

NOMINAL IMPEDANCE: 50 Ω

FREQUENCY RANGE: dc to 40.0 GHz

INSERTION LOSS: 6 dB nominal, 8.0 dB maximum to 26.5, 10.5 dB to 40 GHz
(Between input and either output)

MAXIMUM INPUT POWER: 1.0 watt CW (Input Connector only)

AMPLITUDE & PHASE RACKING (Maximum):

Frequency (GHz)	Tracking	
	Amplitude	Phase
dc - 18	<0.20 dB	<2°
18 - 26.5	<0.30 dB	<2°
26.5 - 40	<0.50 dB	<4°

MAXIMUM INPUT SWR:

Frequency (GHz)	Maximum SWR
dc - 18	1.25
18 - 26.5	1.40
26.5 - 40	1.60

EQUIVALENT OUTPUT SWR (Port 2 & 3):

Frequency (GHz)	Maximum SWR
dc - 26.5	1.35
26.5 - 40	160

*When used in a leveling or ration system.

TEMPERATURE RANGE:

Operating: -55°C to +85°C
Storage: -55°C to +125°C

TEST DATA: Insertion Loss, SWR, and Tracking measurements performed across the frequency band. Test data available at additional cost.

CONNECTORS: Female SMK (2.92mm) connectors all ports--mate nondestructively with SMA, 2.92mm and other 2.92mm and 3.5mm connectors.

WEIGHT: 25 g (0.9 oz) maximum

PHYSICAL DIMENSIONS:

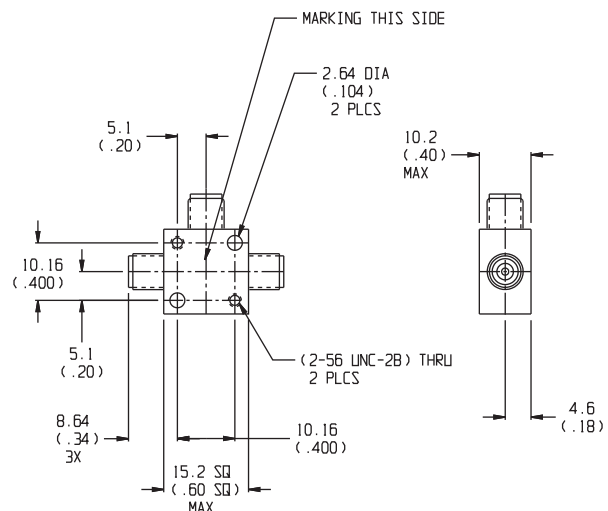

NOTE: All dimensions are given in mm (inches) and are maximum, unless otherwise specified.

Power Splitters & Dividers



Model 1549R Broadband Resistive Power Divider Low Cost, SMA Connectors

dc to 4.0 GHz
1 Watt

RoHS

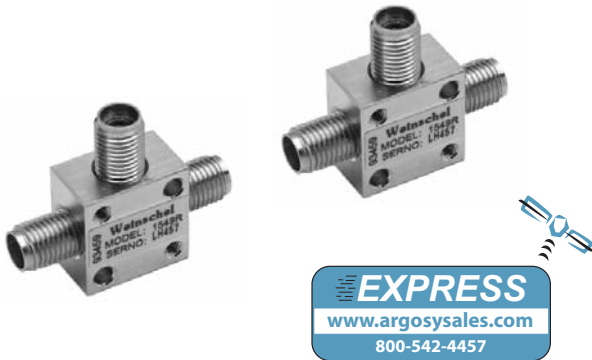

MAXIMUM SWR:		
Frequency (GHz)	Output	Input
dc - 4	1.25	1.25

TEMPERATURE RANGE: -55 °C to +125 °C

CONNECTORS: Female SMA connectors all ports--mate nondestructively with other 2.92mm, SMA and 3.5mm connectors.

WEIGHT: 25 g (0.9 oz) maximum

PHYSICAL DIMENSIONS:

Features

- /// **Excellent Tracking Between Ports.**
- /// **Miniature Size and Light Weight.**
- /// **Wireless Applications** - Ideal for use in the wireless communications bands.

Specifications

NOMINAL IMPEDANCE: 50 Ω

FREQUENCY RANGE: dc to 4.0 GHz

INSERTION LOSS: 6 dB nominal, 6.5 dB maximum
(Between input and either output)

MAXIMUM INPUT POWER: 1.0 watt CW
(input connector only)

NUMBER OF PORTS: 3, Interchangeable for Input and Output.

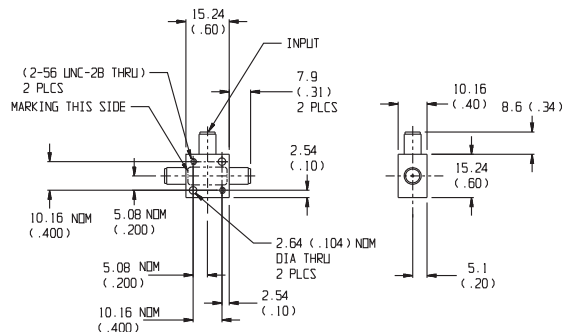

NOTE: All dimensions are given in mm (inches) and are maximum, unless otherwise specified.

AMPLITUDE & PHASE TRACKING (Maximum):

Frequency (GHz)	Tracking	
	Amplitude	Phase
dc - 4.0	<0.2 dB	<4°

Model 1515 & 1515-1 Broadband Resistive Power Divider Ruggedized SMA Connectors

dc to 18.0 GHz
1 Watt

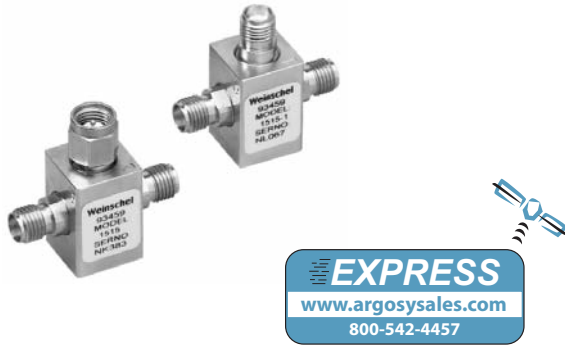

TEMPERATURE COEFFICIENT: < 0.0004 dB/dB/°C
TEMPERATURE RANGE: -55°C to +125°C
CONSTRUCTION: Nickel plated brass body; stainless steel connectors; gold plated beryllium copper contacts.
TEST DATA: Insertion loss data supplied at 50 MHz, 12.0, and 18.0 GHz. Other test data can be provided at additional cost.
CONNECTORS: **Model 1515:** Male SMA connector port 1 and Female SMA connectors ports 2 and 3.
Model 1515-1: SMA Female connectors all ports--all SMA connectors per MIL-STD-348 interface dimensions - mate nondestructively with MIL-C-39012 connectors.
WEIGHT: Net 30 g (1 oz)
PHYSICAL DIMENSIONS:

Features

- Miniature Size & Lightweight - High power capability and high ambient temperature operation.
- Close Tracking & Low Frequency Sensitivity - Output power symmetry is excellent across the frequency range. Division is 6 dB from matched ports.

Specifications

NOMINAL IMPEDANCE: 50 Ω
FREQUENCY RANGE: dc to 18.0 GHz
INSERTION LOSS (between input & either output arm): 6 dB nominal, -0.2 dB, +1.2 to 10 GHz, 1.5 to 18 GHz
MAXIMUM INPUT POWER: 1 watt CW, 1 kilowatt peak (5 μsec pulse width, 0.05% duty cycle)
NUMBER OF PORTS: 3, interchangeable for input and output
PHASE TRACKING: 5° maximum between ports (J2 & J3) with input connector (J1).
POWER COEFFICIENT: < 0.005 dB/dB/watt

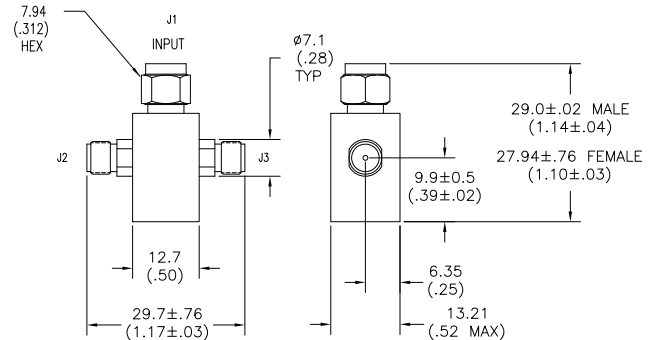

Model No.	Input Connector	Output Connector
1515	SMA Male	SMA Female
1515-1	SMA Female	SMA Female

NOTE: All dimensions are given in mm (inches) and are maximum, unless otherwise specified.

AMPLITUDE TRACKING-J2 & J3 (Maximum):	
Frequency (GHz)	Tracking
dc - 4	0.2 dB
4 - 10	0.4 dB
10 - 18	0.5 dB

MAXIMUM SWR:	
Frequency (GHz)	SWR
dc - 10	1.25
10 - 18	1.35

Power Splitters & Dividers



Model 1506A Broadband Resistive Power Divider Precision N Connectors

dc to 18.0 GHz
1 Watt



MAXIMUM SWR:	
Frequency (GHz)	SWR
dc - 10	1.25
10 - 18	1.35

POWER COEFFICIENT: < 0.005 dB/dB/watt
TEMPERATURE COEFFICIENT: < 0.0004 dB/dB/°C
TEMPERATURE RANGE: -55°C to +125°C
CONSTRUCTION: Nickel plated brass body; stainless steel connectors; gold plated beryllium copper contacts.
TEST DATA: Insertion loss data supplied at 50 MHz, 6.0, 12.0, and 18.0 GHz on nameplate only. No paper data supplied. Other test data can be provided at additional cost.
CONNECTORS: Type N connectors per MIL-STD-348 interface dimensions - mate nondestructively with MIL-C-39012 connectors.
WEIGHT: Net 140 g (5 oz)
PHYSICAL DIMENSIONS:

Features

- /// **Accurate Division and Low Frequency Sensitivity** - The symmetry of output power between the two arms is excellent across the frequency range.
- /// **High Stability** - Low temperature and power coefficients ensure attenuation stability.
- /// **Test Data** - Each divider is calibrated at four frequencies, and the data is supplied on a permanently attached test data plate.
- /// **Matched Ports** - Symmetrical 6 dB division permits any port to be used as input.

Specifications

NOMINAL IMPEDANCE: 50 Ω
FREQUENCY RANGE: dc to 18.0 GHz
MAXIMUM INPUT POWER: 1 watt CW, 1 kilowatt peak (5 μsec pulse width, 0.05 % duty cycle)
INSERTION LOSS (between input & one output arm): 6 dB nominal, -0.2, +1.2 dB maximum to 10.0 GHz; +1.5 dB maximum to 18.0 GHz.
NUMBER OF PORTS: 3, interchangeable for input and output
PHASE TRACKING: 5° maximum between ports (J2 & J3) with input connector (J1).

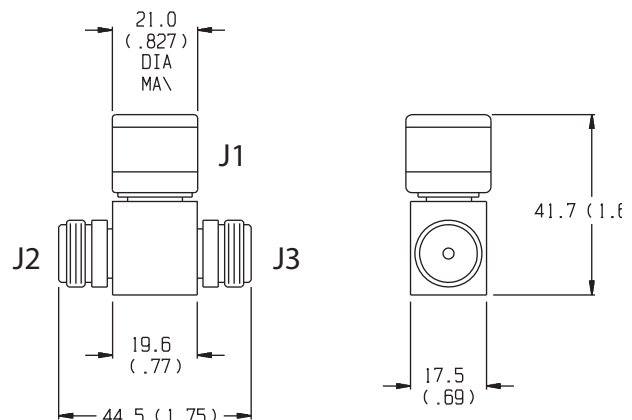

NOTE: All dimensions are given in mm (inches) and are maximum, unless otherwise specified.

AMPLITUDE TRACKING (Maximum):	
Frequency (GHz)	Tracking
dc - 4	0.2 dB
4 - 10	0.4 dB
10 - 18	0.5 dB

Models 1580 & 1580-1
Broadband Resistive Power Dividers
3.5mm Connectors

dc to 26.5 GHz
1 Watt

RoHS



MAXIMUM SWR:	
Frequency (GHz)	SWR
dc - 18	1.20
18 - 26.5	1.30

CONSTRUCTION: Gold plated brass body; stainless steel connectors; gold plated beryllium copper contacts.

TEST DATA: Insertion loss, SWR and Tracking data covering 153 frequency points between 50 MHz and 26.5 GHz.

CONNECTORS:

Model 1580: Male 3.5mm connector port 1 and Female 3.5mm connectors ports 2 and 3--all mate nondestructively with SMA, 2.92mm and other 3.5mm connectors.

Model 1580-1: Female 3.5mm connectors all ports--mate nondestructively with SMA, 2.92mm and other 3.5mm connectors.

PHYSICAL DIMENSIONS:

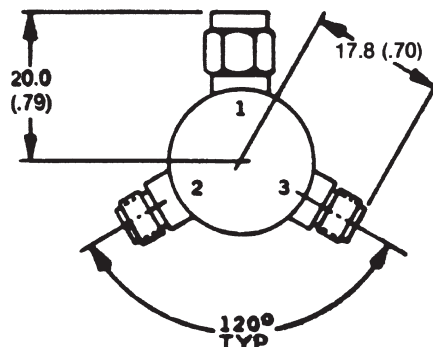
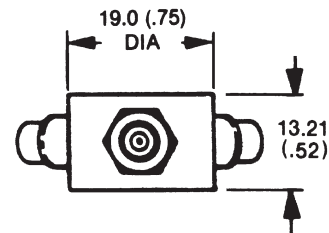

NOTE: All dimensions are given in mm (inches) and are maximum, unless otherwise specified.

Features

- /// **Miniature Size & Lightweight** - High power capability and high ambient temperature operation.
- /// **Close Tracking & Low Frequency Sensitivity** - Output power symmetry is excellent across the frequency range. Division is 6 dB from matched ports.
- /// **Test Data** - Provided for 153 frequency points

Specifications

NOMINAL IMPEDANCE: 50 Ω

FREQUENCY RANGE: dc to 26.5 GHz

MAXIMUM INPUT POWER: 1 watt CW, 500 watt pulse

INSERTION LOSS (between input & one output arm): 6 dB nominal, 7.5 maximum to 18 GHz and 8.5 maximum to 26.5 GHz.

NUMBER OF PORTS: 3, interchangeable for input and output

TRACKING (Maximum):

Frequency (GHz)	Amplitude	Phase
dc - 26.5	0.30 dB	8°

POWER COEFFICIENT: < 0.005 dB/dB/watt

TEMPERATURE COEFFICIENT: < 0.0004 dB/dB/°C

TEMPERATURE RANGE: -55°C to +125°C

Power Splitters & Dividers



Model 1575 Broadband Resistive Power Divider Subminiature, SMK Connectors

dc to 40.0 GHz
1.0 Watt

RoHS

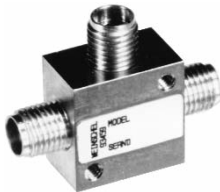

Features

This three resistor Power Divider is designed for applications where an RF and Microwave signal must be accurately divided or combined.

- /// **Miniature Size and Lightweight** - High power capability and high ambient temperature operation.
- /// **Close Tracking and Low Frequency Sensitivity** - Output power symmetry is excellent across the frequency range. Division is 6 dB from matched ports.

Specifications

NOMINAL IMPEDANCE: 50 Ω
FREQUENCY RANGE: dc to 40.0 GHz
INSERTION LOSS (Between input and either output):
 6 dB nominal, 8.5 dB maximum
MAXIMUM INPUT POWER: 1.0 watts CW, 1 kilowatt peak, 5 μsec pulse width
NUMBER OF PORTS: 3, interchangeable for input and output

AMPLITUDE & PHASE TRACKING (Maximum):

Frequency (GHz)	Tracking	
	Amplitude	Phase
dc - 19	<0.25 dB	2°
19 - 40	<0.50 dB	5°

MAXIMUM SWR:

Frequency (GHz)	SWR
dc - 19	1.40
19 - 40	1.70

TEMPERATURE RANGE: -55°C to +85°C

TEST DATA: Insertion Loss, SWR, and Tracking measurements performed across the frequency band. Test data available at additional cost.

CONNECTORS: Female SMK (2.92mm) connectors all ports--mate nondestructively with SMA, 2.92mm and other 2.92mm and 3.5mm connectors.

WEIGHT: 25 g (0.9 oz) maximum

PHYSICAL DIMENSIONS:

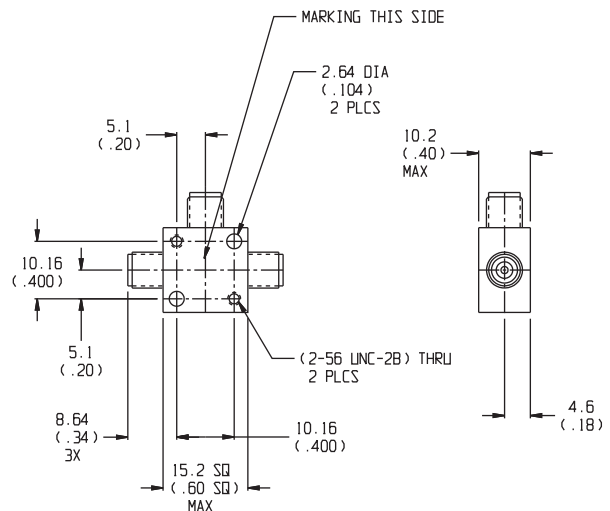

NOTE: All dimensions are given in mm (inches) and are maximum, unless otherwise specified.

Model 1550A

Model 1594

4-WAY Resistive Power Dividers

Subminiature, SMA / 3.5mm Connectors

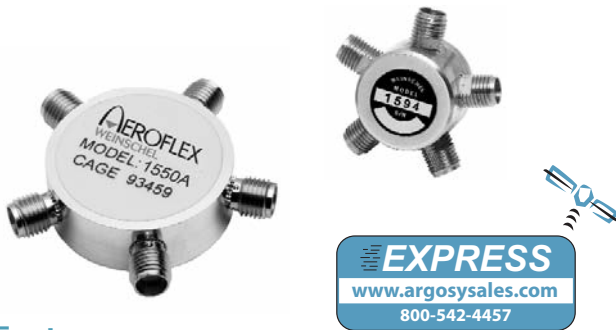

Features

- /// **Broadband Performance.**
- /// **Excellent Tracking Between Ports.**
- /// **Miniature Size and Light Weight.**
- /// **Wireless Applications** - Model 1550A is specifically designed for use in the wireless communications bands.

Specifications

NOMINAL IMPEDANCE: 50 Ω

FREQUENCY RANGE: 1550A: dc to 3.0 GHz (usable to 5 GHz)
1594: dc to 18.0 GHz

INSERTION LOSS*:

Model 1550A: 12 dB nominal, 13.5 dB maximum
Model 1594: 12 dB nominal, 14.5 dB maximum
* input port to any output port with all other terminated.

MAXIMUM INPUT POWER: 1550A: 1 watt CW
1594: 2 watts CW

AMPLITUDE & PHASE TRACKING (Maximum):

Model No.	Frequency (GHz)	Tracking*	
		Amplitude	Phase
1550A	dc - 3	±0.5 dB	±10°
1594	dc - 12	<2.0 dB	<30°
	12 - 18	<2.5 dB	<50°

*Between output ports.

NUMBER OF PORTS: 1 input and 4 outputs

TEMPERATURE RANGE: -55°C to +100°C

CONNECTORS: Model 1550A: SMA female connectors all ports--mate nondestructively with other SMA, 2.92mm and 3.5mm connectors.

Model 1594: 3.5mm female connectors all ports--mate non-destructively with other SMA, 2.92mm and 3.5mm connectors.

MAXIMUM SWR:

Model No.	SWR
1550A	1.25
1594	1.30

WEIGHT: 1550A: 28 g (1.0 oz) maximum
1594: 30 g (1.05 oz) maximum

PHYSICAL DIMENSIONS:

Model 1550A:

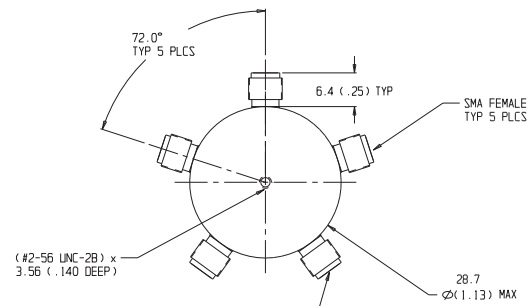
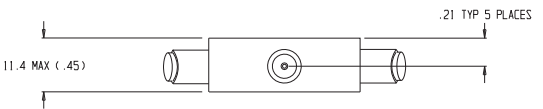

CAUTION: TORQUE ON CONNECTORS NOT TO EXCEED 7 TO 10 INCH POUNDS (PER MIL-C-39012). THESE CONNECTORS ARE PRESS FIT. EXCEEDING THIS MAY CAUSE CONNECTOR TO COME LOOSE.

Model 1594:

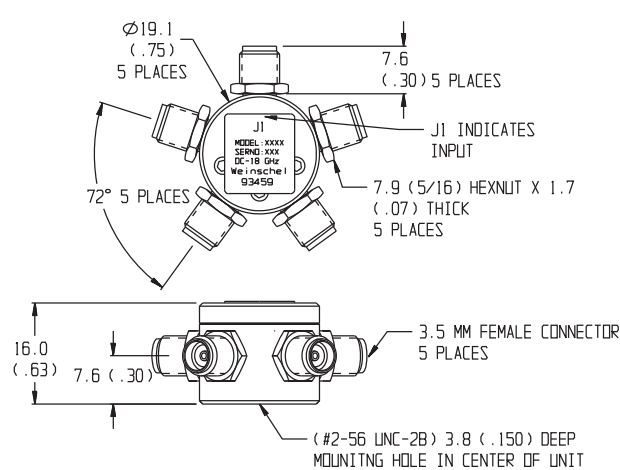

NOTE: All dimensions are given in mm (inches) and are maximum, unless otherwise specified.

Mechanical Phase Shifters

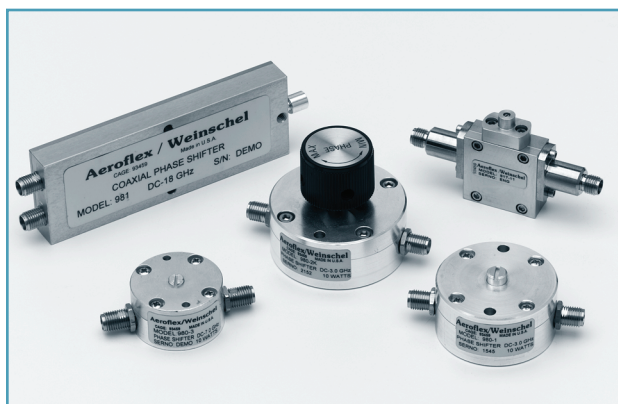

- /// DC to 20 GHz; Low Loss; Linear
- /// **Self Locking** - Internal mechanism eliminates the need for a locking nut. Ideal for phase trimming in densely packaged systems with minimum accessibility.
- /// **EDGE LINE** designs for ultra fine resolution to 22 GHz
- /// **COAXIAL** designs for broadband low-loss operation to 18 GHz
- /// **STRIPLINE** designs for lower cost applications to 12 GHz

General Information

In this section of the catalog, each Phase Shifter is outlined utilizing individual data sheets containing product features, specifications, and outline drawings. These data sheets are preceded by a quick reference guide to help you select the Phase Shifter(s) that fits your needs. The page number for each phase shifter data sheet is given in the quick reference guide.





Aeroflex / Weinschel offers a variety of Mechanical Phase Shifter designs that are ideally suited for delay line applications in optical and RF Networks. These designs provide linear adjustable phase shift in a very small in-line coaxial packages with long mechanical cycle life. Models can also be easily adapted to motorized control configurations.

NOTE: **EXPRESS** Shipment available via www.argosysales.com or 800-542-4457. Check with distributor for current products and stocking quantities.





Phase Shifters...dc to 20 GHz

Model Number	Frequency Range (GHz)	Connector Type	Incremental Phase Shift (Minimum)	Insertion Phase (Typical)	Average Power (Watts)	Maximum Insertion Loss (dB)	Maximum SWR	Page No.	
♦ 917	dc to 20.0	SMK (2.92mm)	225° @ 20 GHz, 100° at 9 GHz.	890° @ 10 GHz	20	0.8	1.50	169	
980-1	dc to 3.0	SMA	140° @ 3.0 GHz	560° @ 3.0 GHz	10	0.7-1.2*	1.30	167	
♦ 980-2	dc to 3.0	SMA	340° @ 3.0 GHz	780° @ 3.0 GHz	10	1.5-2.0*	1.35		
♦ 980-3	dc to 7.0	SMA	170° @ 7.0 GHz	700° @ 3.0 GHz	10	0.5	1.30		
♦ 980-4	dc to 12.4	SMA	290° @ 12.0 GHz	1200° @ 12.0 GHz	10	1.0	1.45		
980K-1	dc to 3.0	SMA	140° @ 3.0 GHz	560° @ 3.0 GHz	10	0.7-1.2*	1.30	167	
♦ 980K-2	dc to 3.0	SMA	340° @ 3.0 GHz	780° @ 3.0 GHz	10	1.5-2.0*	1.35		
980K-3	dc to 7.0	SMA	170° @ 7.0 GHz	700° @ 3.0 GHz	10	0.5	1.30		
980K-4	dc to 12.4	SMA	290° @ 12.0 GHz	1200° @ 12.0 GHz	10	1.0	1.45		
♦ 981	dc to 18.0	3.5mm	60° /GHz	1350@9.0 GHz	50 f = GHz	0.5+0.035 f *	1.80	170	

* VARIES WITH FREQUENCY.

♦ EXPRESS Shipment available via www.argosysales.com or 800-542-4457.

Note: Other models may also be available from Express delivery.

Frequently Asked Questions about Phase Shifters . . .

Can you define the Characteristic Insertion Phase for a Mechanical Phase Shifter?

Mechanical phase shifters have an inherent delay / Zero phase shift even when sitting in the minimum position. That phase is the Characteristic Insertion Phase and is provided as a typical value.

Insertion phase is considered the fixed value of the phase shifter and is measured at the minimum setting.

What is Incremental phase shift?

Incremental phase shift is the adjustable amount of phase at a given frequency, over and above the insertion phase.

How is the absolute phase shift calculated for Model 980 series?

The absolute phase shift at any desired frequency is equal to the insertion phase plus the incremental adjustable phase.

The adjustable phase shift is realized in a total rotation of approximately ¼ turn of the adjustment shaft/knob. (minimum to maximum)

Phase vs. Frequency is a nominally linear response

$$\text{Time Delay} = \frac{\Delta\theta}{2\pi f} = \text{pSec}$$

$$\Delta\theta \text{ in radians, } f \text{ in GHz}$$

As frequency changes, phase shift change linearly, but time delay remains the same.

Mechanical Phase Shifters



Model 980 Coaxial Phase Shifters SMA Connectors

dc to 3.0/7.0/12.0 GHz
10 Watts

RoHS

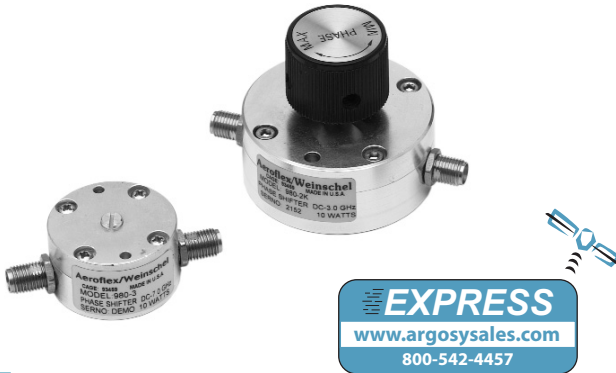

Features

- /// **Self Locking** - Internal mechanism eliminates the need for a locking nut. Ideal for phase trimming in densely packaged systems with minimum accessibility.
- /// **Available Express Models** - 980-2, 980-2K, 980-3, 980-4
Other models may be available for Express Delivery.
- /// **Linear** - Nominally linear phase over the frequency range.
- /// **Optimized for Wireless OEM Applications.**
- /// **New Models with Adjustment Knobs**
(See Models 980-1K through 980-4K).

Specifications

NOMINAL IMPEDANCE: 50 Ω

FREQUENCY RANGE:

Model 980-1 & 980-1K: dc to 3.0 GHz
 Model 980-2 & 980-2K: dc to 3.0 GHz
 Model 980-3 & 980-3K: dc to 7.0 GHz
 Model 980-4 & 980-4K: dc to 12.0 GHz

INCREMENTAL PHASE SHIFT (typical):

Model 980-1 & 980-1K: 140° @ 3.0 GHz
 Model 980-2 & 980-2K: 340° @ 3.0 GHz
 Model 980-3 & 980-3K: 170° @ 7.0 GHz
 Model 980-4 & 980-4K: 290° @ 12.0 GHz

Incremental phase shift is adjustable phase range over and above it's insertion phase

PHASE VS FREQUENCY: Nominally linear response

INSERTION PHASE:

Model 980-1 & 980-1K: 560° (Typical) @ 3.0 GHz
 Model 980-2 & 980-2K: 780° (Typical) @ 3.0 GHz
 Model 980-3 & 980-3K: 700° (Typical) @ 7.0 GHz
 Model 980-4 & 980-4K: 1200° (Typical) @ 12.0 GHz

MAXIMUM INSERTION LOSS (dB):

Model No.	Frequency Range (GHz)			
	1.5	3.0	7.0	12.0
980-1 & -1K	0.70 dB	1.20 dB	---	---
980-2 & -2K	1.50 dB	2.00 dB	---	---
980-3 & -3K	0.50 dB	0.50 dB	0.50 dB	---
980-4 & -4K	1.00 dB	1.00 dB	1.00 dB	1.00 dB

MAXIMUM SWR:

Frequency Range (GHz)	Model No.			
	980-1/1K	980-2/2K	980-3/3K	980-4/4K
dc - 3	1.30	1.35	1.30	1.30
3 - 7	---	---	1.30	1.30
7 - 12	---	---	---	1.60

POWER RATING: 10 watts average

TEMPERATURE RANGE:

Operating: -50°C to 85°C
 Storage: -50°C to 125°C

CONNECTOR: SMA female connector per MIL-STD-348 interface dimensions - mate nondestructively with MIL-C-39012 connector.

WEIGHT: Models 980-1 & 980-2: 65 g (2.29 oz)
 Models 980-1K & 980-2K: 78 g (2.75 oz)
 Model 980-3 & 980-4: 35 g (1.24 oz)
 Model 980-3K & 980-4K: 48 g (1.69 oz)

PHYSICAL DIMENSIONS:

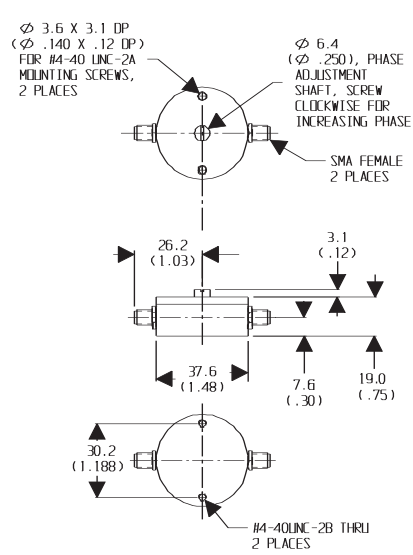

MODEL 980-1

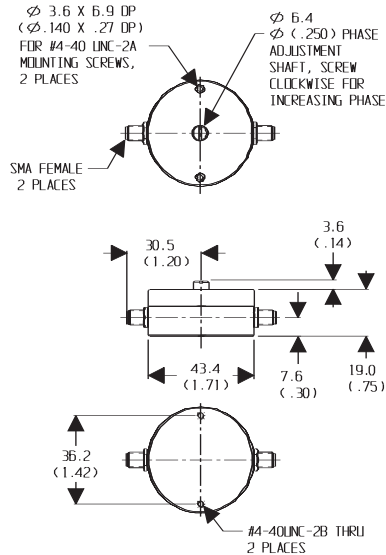

MODEL 980-2

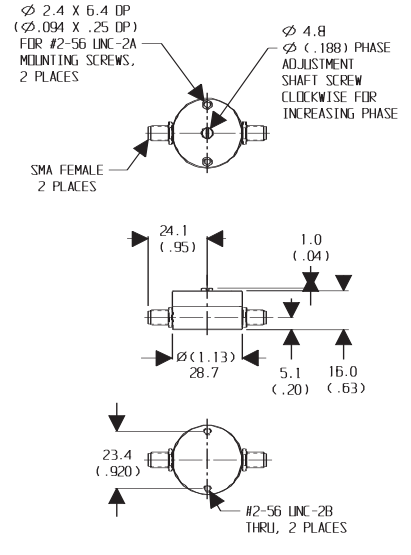

MODELS 980-3 & 980-4

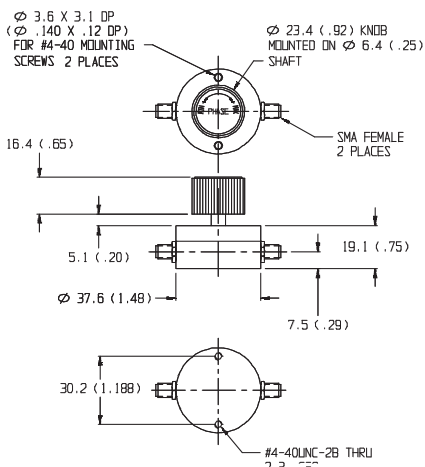

MODEL 980-1K

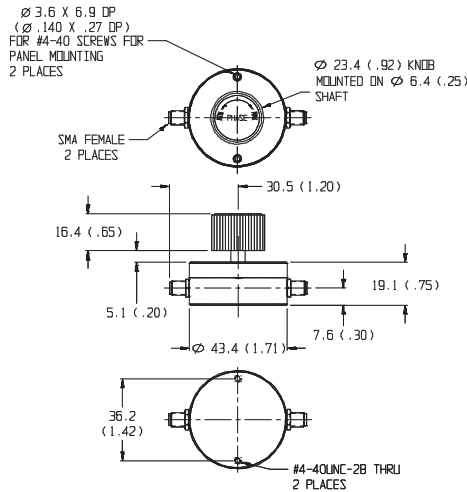

MODEL 980-2K

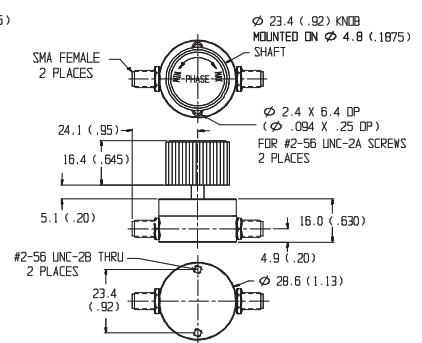

MODEL 980-3K & 980-4K

NOTE: All dimensions are given in mm (inches) and are maximum, unless otherwise specified.

Mechanical Phase Shifters



Model 917 Miniature In-Line Phase Shifter Ruggedized 2.92mm Connector

dc to 20.0 GHz
20 Watts



CONNECTOR: SMK (2.92mm) connector compatible with SMA, 3.5mm, SMK and other 2.92mm connectors. Available connector options are:

Connector Options	Type/Description
1	SMK, Female
2	SMK, Male

WEIGHT: 45 g (1.6 oz)

PHYSICAL DIMENSIONS:

Features

- /// **Self Locking** - Internal mechanism eliminates the need for a locking nut. Ideal for phase trimming in densely packaged systems with minimum accessibility.
- /// **Linear** - Provides a linear adjustable phase shift to 20 GHz in a very small in-line coaxial package.

Specifications

NOMINAL IMPEDANCE: 50 Ω

FREQUENCY RANGE: dc to 20.0 GHz

INCREMENTAL PHASE SHIFT: Adjustable to 225° @ 20 GHz; 100° at 9 GHz (typical).

RESOLUTION: 0.5° per turn per GHz, typical
(Adjustment shaft has 20 turns for full range).

INSERTION PHASE: 890° @ 10 GHz (Typical)

PHASE VS FREQUENCY: Nominally linear response

INSERTION LOSS: 0.8 dB maximum
(0.5 dB typical @ 20 GHz)

MAXIMUM SWR:

Frequency Range (GHz)	SWR
dc - 20	1.5

POWER RATING: 20 watts average

TEMPERATURE RANGE: -55°C to 125°C.

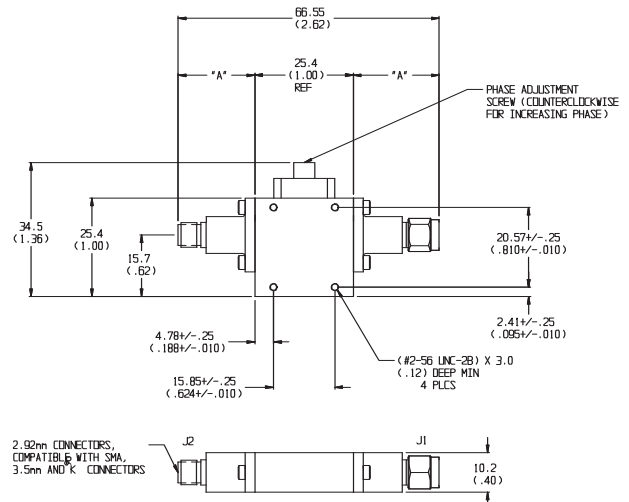

2.92mm CONNECTORS, COMPATIBLE WITH SMA, 3.5mm AND K CONNECTORS

CONN TYPE	DIM A
Female	19.81 (0.78)
Male	21.34 (0.84)

NOTE: All dimensions are given in mm (inches) and are nominal ±0.5 (0.02), unless otherwise specified.

MODEL NUMBER DESCRIPTION:

Example:

917 - XX

Basic Model Number

Connector Options*
1st digit is J1 side
2nd digit is J2 side

Model 981 Coaxial Phase Shifter 3.5mm Connectors

dc to 18.0 GHz
50 Watts



Specifications

NOMINAL IMPEDANCE: 50 Ω
FREQUENCY RANGE: dc to 18.0 GHz
INCREMENTAL PHASE SHIFT (Typical): 60° /GHz
INSERTION PHASE: 1350° @ 9.0 GHz (typical)
INSERTION LOSS (dB): 0.5 + 0.035 f(GHz)

MAXIMUM SWR:

Frequency Range (GHz)	SWR
dc - 10	1.6
10 - 18	1.8

Features

- /// **Broadband Frequency Coverage:** Operates from dc to 18 GHz, usable to 20 GHz
- /// **Ideally suited for delay line applications in optical and RF Networks.**
- /// **Easily adapts to motorized control configurations.**
- /// **Designed for long mechanical cycle life.**

POWER RATING: 50 watts average, 1 kW peak
TEMPERATURE RANGE: -50°C to 100°C.
CONNECTOR: 3.5mm female connectors compatible with 3.5mm, SMA, SMK and other 2.92mm connectors.
WEIGHT: 80 g (2.84 oz)

PHYSICAL DIMENSIONS:

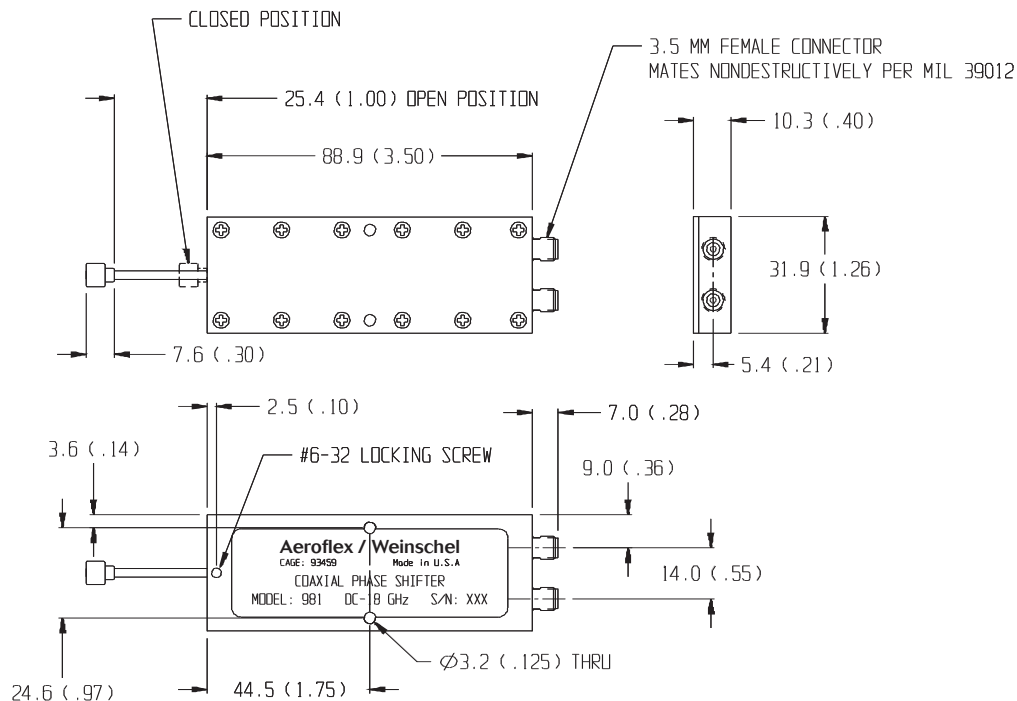

NOTE: All dimensions are given in mm (inches) and are maximum unless otherwise specified.

DC Blocks



- /// Inside & outside versions available.
- /// **Express** shipment available on select models.
- /// Low SWR - Maximum SWR remains low through full frequency and power range.
- /// Rugged Construction - Aeroflex / Weinschel semi-precision Type N & SMA stainless steel connectors.
- /// Broadband Designs to 26 GHz.
- /// Planar Bulkhead Models with inside DC Block.

General Information

In this section of the catalog, each product is outlined utilizing individual data sheets containing product features, specifications, and outline drawings. These data sheets are preceded by a quick reference guide to help you select the product(s) that fits your needs. The page number for each product data sheet is given in the quick reference guide.

NOTE: **EXPRESS** Shipment available via www.argosysales.com or 800-542-4457. Check with distributor for current products and stocking quantities.

dc Blocks...dc to 18.0 GHz

Model Number	Type	Connector Type	Frequency Range (GHz)	Insertion Loss Maximum (dB)	SWR (Maximum)	Page No.	
★ 7003	Inside	N	9 kHz to 18.6	0.9	1.35-1.50*	172	
★ 7006-1	Inside	SMA	9 kHz to 20	0.8	1.30-1.50*	173	
7010-1	Inside	SMA (f) - Planar Interface	dc - 26.5	0.6-0.9	1.20-1.25	174	
7010-2	Inside	SMA (m) - Planar Interface	dc - 26.5	0.6-0.9	1.20-1.25	174	
★ 7012	Inside/Outside	SMA	0.5 to 8.6	0.4	1.25	175	

* VARIES WITH FREQUENCY.

★ **EXPRESS** Shipment available via www.argosysales.com or 800-542-4457.
Note: Other models may also be available from Express delivery.

Model 7003 Inside DC Block

9 kHz to 18.6 GHz

Type N Connectors



Features

Aeroflex / Weinschel Inside dc Block contains capacitance in-series with the center conductor to prevent the flow of dc current, while permitting RF power to flow without interruption.

- /// **Low SWR** - Maximum SWR remains low through full frequency and power range.
- /// **Rugged Construction** - Aeroflex / Weinschel semi-precision Type N stainless steel connectors. Molded captive inner contact/bead assembly provides controlled and stable interface dimensions.
- /// **Model 7003 useable to 22 GHz.**

Specifications

NOMINAL IMPEDANCE: 50 Ω

FREQUENCY RANGE: 9 kHz to 18.6 GHz

MAXIMUM SWR:	
Frequency (GHz)	SWR*
9 - 20 kHz	1.50
20 kHz - 18	1.35

* Source & load SWR of test system is <1.2.

INSERTION LOSS: 0.9 dB maximum

VOLTAGE RATING: +50 Vdc maximum

POWER RATING: 20 Watts (average), 100 Watts (peak)

TEMPERATURE RANGE: -20 °C to +80 °C (operating)
-20 °C to +100 °C (storage)

TEST DATA: Test data is available at additional cost.

CONNECTORS: Type N connectors per MIL-STD-348 interface dimensions - mate nondestructively with MIL-C-39012 connectors. Standard unit has one male and one female connector. Add Prefix M for double male and F for double female connectors.

CONSTRUCTION: Stainless steel body and connectors; gold plated beryllium copper contacts

WEIGHT: Net: 67 g (2.4 oz)

PHYSICAL DIMENSIONS:

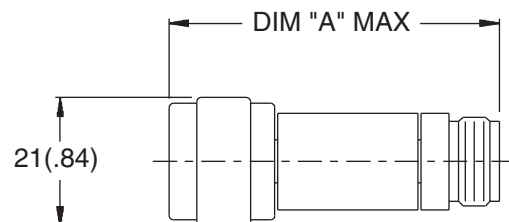

Model #	DIM A	Connector Type
7003	54.61 (2.15)	male-female
F7003	50.80 (2.00)	female-female
M7003	58.67 (2.31)	male-male

NOTE: All dimensions are given in mm (inches) and are maximum, unless otherwise specified.

SCHEMATIC DIAGRAM:

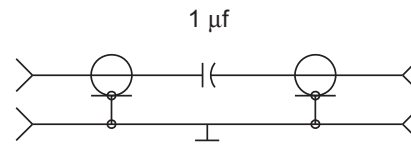

Model 7006-1 Inside DC Block

9 kHz to 20.0 GHz

Rugged SMA Connectors



Features

Aeroflex / Weinschel Inside dc Block contains capacitance in-series with the center conductor to prevent the flow of dc current, while permitting RF power to flow without interruption.

- /// **Low SWR** - Maximum SWR remains low through full frequency and power range.
- /// **Rugged Construction** - Aeroflex / Weinschel semi-precision SMA stainless steel connectors. Molded captive inner contact/bead assembly provides controlled and stable interface dimensions.

Specifications

NOMINAL IMPEDANCE: 50 Ω

FREQUENCY RANGE: 9 kHz to 20 GHz

MAXIMUM SWR:	
Frequency (GHz)	7006-1
9 - 10 kHz	1.50
11 - 20 kHz	1.50
20 kHz - 20.0	1.30

* Source & load SWR of test system is <1.2.

INSERTION LOSS: 0.8 dB maximum*

VOLTAGE RATING: +50 Vdc maximum

POWER RATING: 20 Watts (average), 100 Watts (peak)

TEMPERATURE RANGE: -20 °C to +80 °C (operating)
-20 °C to +100 °C (storage)

TEST DATA: Test data is available at additional cost.

CONNECTORS: SMA connectors per MIL-STD-348 interface dimensions - mate nondestructively with MIL-C-39012 connectors. Standard unit has one male and one female connector. Add Prefix M for double male and F for double female connectors.

CONSTRUCTION: Stainless steel body and connectors; gold plated beryllium copper contacts

WEIGHT: Net:: 4 g (0.14 oz)

PHYSICAL DIMENSIONS:

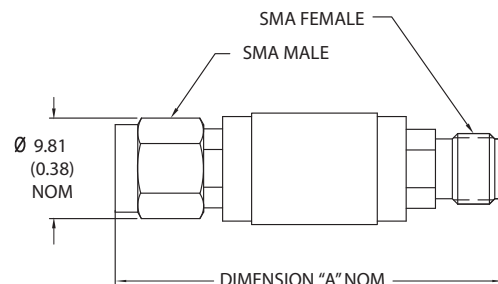

Model #	DIM A	Connector Type
7006-1	37.34 (1.47)	male-female
F7006-1	34.54 (1.36)	female-female
M7006-1	36.07 (1.42)	male-male

NOTE: All dimensions are given in mm (inches) and are maximum, unless otherwise specified.

SCHEMATIC DIAGRAM:

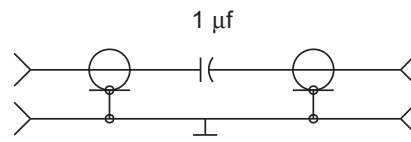

Model 7010 PLANAR BULKHEAD with DC Block

10 MHz to 26.5 GHz

SMK Connectors to Planar Interface



Features

- /// Usable to 40 GHz.
- /// Eliminates the requirement for a separate dc Block to protect instrument front ends.
- /// Offers the user multiple connector options and quick replacement of damaged connectors.
- /// Provides all the features and versatility of the PLANAR CROWN® Connector System.

Specifications

NOMINAL IMPEDANCE: 50 Ω

FREQUENCY RANGE: 10 MHz to 26.5 GHz

MAXIMUM SWR:

Frequency (GHz)	SWR
10 MHz - 18	1.20
18 - 26.5	1.25

INSERTION LOSS & REPEATABILITY (dB):

Frequency (GHz)	Loss
10 MHz - 18	0.6
18 - 26.5	0.9

Note: SWR and Insertion Loss specifications are based on a mated pair of Models 7010-X and 7005A-XX PLANAR CROWN® connector types.

DC BLOCK CAPACITOR RATING: 1,700 pf minimum;
+ 50 Vdc working voltage

SCHEMATIC DIAGRAM:

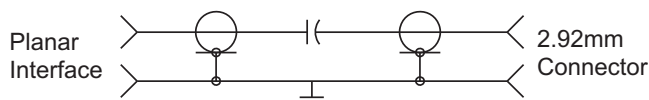

TEMPERATURE RANGE: 0°C to +60°C (operating)
-40°C to +70°C (non-operating)

CONNECTORS: Primary connector is SMK (2.92 mm) female or male connector, with a PLANAR INTERFACE on opposite end. Contact Pin Recession of SMK (2.92mm) is 0 to 0.076 mm (0 to 0.003 in) for reference plane. Add -1 for female SMK connector or -2 for SMK male connector

CONSTRUCTION: Passivated Stainless steel body and connectors; gold plated beryllium copper contacts

WEIGHT: Net: 20 g (0.7 oz)

PHYSICAL DIMENSIONS:

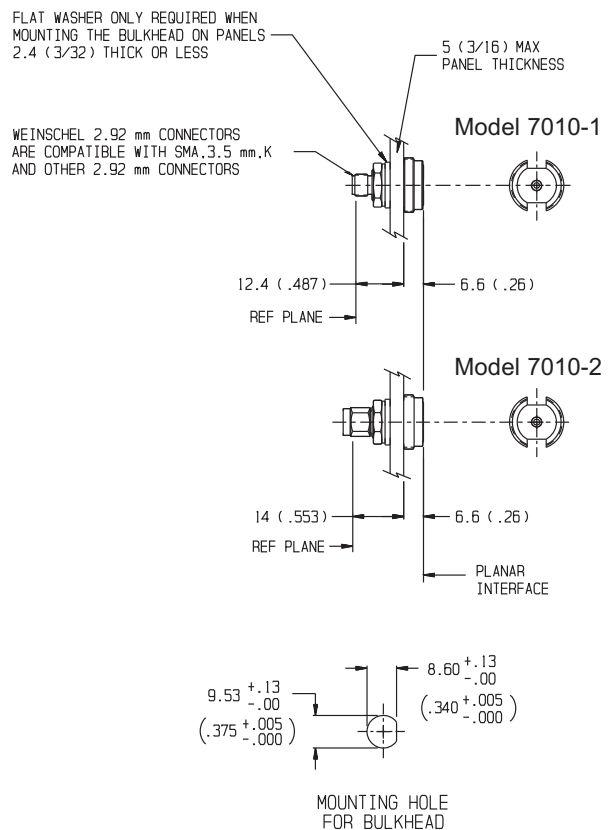

NOTE: All dimensions are given in mm (inches) and are maximum, unless otherwise specified.

DC Blocks



Model 7012 Inside/Outside DC Block

500 MHz to 8.6 GHz

Rugged SMA Connectors



Features

Aeroflex / Weinschel Inside/Outside dc Block contains capacitance in-series with the center conductor to prevent the flow of dc current, while permitting RF power to flow without interruption.

- /// **Low SWR** - Maximum SWR remains low through full frequency and power range.
- /// **Rugged Construction** - Aeroflex / Weinschel semi-precision SMA stainless steel connectors.

Specifications

NOMINAL IMPEDANCE: 50 Ω
FREQUENCY RANGE: 500 MHz to 8.6 GHz

MAXIMUM SWR:	
Frequency (GHz)	SWR
500 MHz - 8.6 GHz	1.25

INSERTION LOSS (dB maximum):	
Frequency (GHz)	Loss
500 MHz - 8.6 GHz	0.4

BREAKDOWN VOLTAGE: + 200 Vdc between any of the four connectors

DC RESISTANCE: 20 MΩ minimum between any four connectors

POWER RATING: 10 Watts peak or CW

CONNECTORS: SMA connectors per MIL-STD-348 interface dimensions - mate nondestructively with MIL-C-39012 connectors. Standard unit has one male and one female connector.

CONSTRUCTION: Stainless steel body and connectors; gold plated beryllium copper contacts

WEIGHT: Net: 4.6 g (0.16 oz)

PHYSICAL DIMENSIONS:

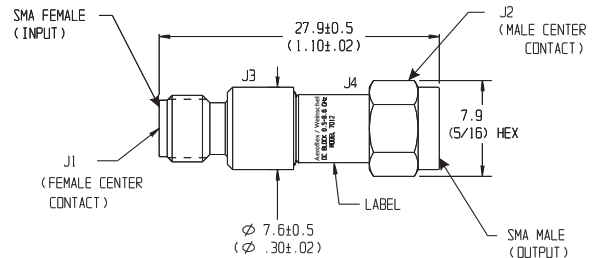

NOTE: All dimensions are given in mm (inches) and are maximum, unless otherwise specified.

SCHEMATIC DIAGRAM:

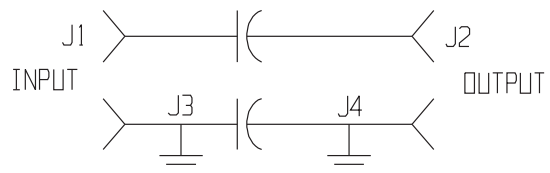

Coaxial Adapters

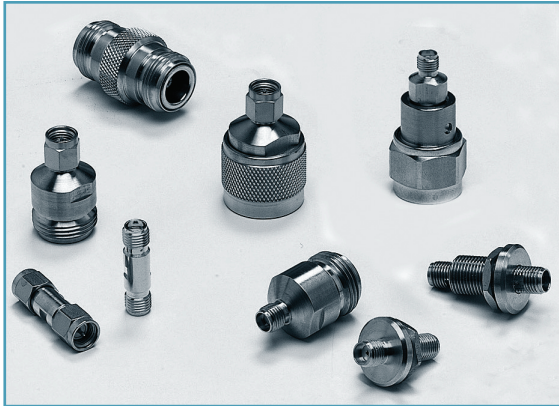

- /// High Repeatability & Low SWR
- /// Rugged Injection Molded Connectors.
- /// Bulkhead Mounting - Model 1568 conveniently mounts on any panel using a standard D-hole.
- /// In-Series & Between Series Configurations - Type N or SMA
- /// Precision Connectors & Rugged Construction

General Information

In this section of the catalog, each product is outlined utilizing individual data sheets containing product features, specifications, and outline drawings. These data sheets are preceded by a quick reference guide to help you select the product(s) that fits your needs. The page number for each product data sheet is given in the quick reference guide.





The superior performance Aeroflex / Weinschel components enjoy is due to our connector design capabilities. Utilizing proprietary design techniques, we offer connectorized devices that are mechanically robust, stable over environmental extremes, and highly reliable. Aeroflex / Weinschel offers a comprehensive line of between-series adapters, blind-mate connectors, and our patented PLANAR CROWN® Connector System.

NOTE: *EXPRESS* Shipment available via www.argosysales.com or 800-542-4457. Check with distributor for current products and stocking quantities.





Precision Adapters...dc-26.5 GHz

MODEL NUMBER	CONNECTOR TYPE	FREQUENCY RANGE	SWR (MAXIMUM)	INSERTION LOSS	REPEATABILITY	Page No.	
♦ F1513 ♦ M1513	N female - N female N male - N male	dc - 18	1.10-1.15*	<0.25	0.020 dB	182	
♦ 1548-13 ♦ 1548-14 ♦ 1548-23 ♦ 1548-24	SMA female - N female SMA female - N male SMA male - N female SMA male - N male	dc - 18	1.10	0.43 (maximum) per mated pair	Type N: 0.006-0.010* SMA: 0.010-0.020*	184	
♦ 1568 ♦ 1568-1	SMA (female-female) bulkhead (add -1 to model number for stainless steel)	dc - 26.5	1.15-1.20*	<0.30 - <0.50*	0.010-0.020*	180	
♦ 1587 ♦ 1588 ♦ 1589	SMA female - SMA female SMA male - SMA female SMA male - SMA male	dc - 26.5	1.15-1.20*	<0.30 - <0.50*	0.010-0.020*	181	
♦ 7002-13 ♦ 7002-14 ♦ 7002-23 ♦ 7002-24	SMA female to N female SMA female to N male SMA male to N female SMA male to N male	dc - 18	1.12	<0.40 - <0.50*	0.010-0.020*	183	

♦ EXPRESS Shipment available via www.argosysales.com or 800-542-4457.
Note: Other models may also be available from Express delivery.

* VARIES WITH FREQUENCY

Coaxial Adapters



Frequently Asked Questions about Adapters Precision Connector Systems...

What types of adapters and/or connectors does Aeroflex / Weinschel offer?

Aeroflex / Weinschel offers a wide variety of precision SMA, 2.92mm, Type N, 3.5mm, 2.4mm and male, female, and sexless combinations of adapters from which to choose. Also, Aeroflex / Weinschel manufactures a wide range of Blind-mate Connectors and our own PLANAR CROWN® Connector System. All Aeroflex / Weinschel components are designed and manufactured to obtain low SWR and excellent repeatability over the longest possible operational life. Other features of Aeroflex / Weinschel Adapters and Connectors include:

1. High Repeatability.
2. Quality Connectors - SMA, Type N, 3.5mm, 2.92mm, and 2.4mm.
3. Bulkhead Mounting Available
4. Broad Frequency Range - dc to 40 GHz.

What are Blind-mate Connectors and where would I use them?

Aeroflex / Weinschel Blind-mate connector series provides threadless connector mating which is useful when mating an array of connectors on one RF module to another array within seconds. Each connector pair will tolerate a radial and axial offset of 0.02 inch and still meet all of its electrical specifications. These connectors simplify RF connections in the most inaccessible regions and high package density systems where conventional threaded connector mating is extremely difficult.

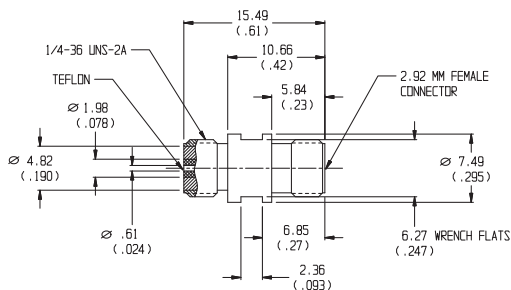

What is difference between Aeroflex / Weinschel precision SMA/ 2.92mm connectors and other SMA connectors?

Typical commercial SMA connectors may have a useful SWR to 18 or 26 GHz; however, most absorb energy between 22 and 25 GHz due to TEM mode conversion. A mated pair could have between 0.5 dB to 2.0 dB insertion loss. A mated pair of Aeroflex / Weinschel Precision Miniature connectors (2.92mm), which mate with SMA type connectors, have a VSWR of less than 1.25 and an insertion loss of less than 0.5 dB to 26 GHz. The new 2.92mm expands this range to 40 GHz.



What is the advantages of using Aeroflex / Weinschel PLANAR CROWN® connectors?.

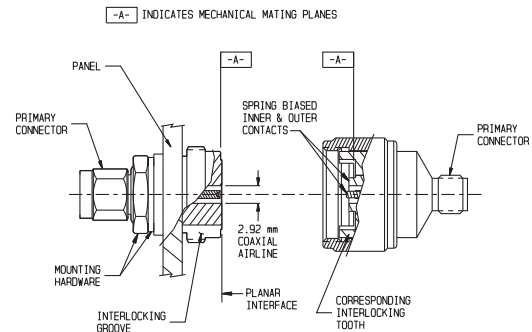

The Aeroflex / Weinschel PLANAR CROWN® Universal Connector System incorporates design and application features that eliminate the mechanical, electrical and economical drawbacks of standard bulkhead connectors, connector savers, cable connectors and adapters. In one standard design, it has resolved connector related problems faced by users and manufacturers of instruments, cables and components, how to quickly and inexpensive to change connector series or replace damaged front panel connectors on instruments. This system features an operating frequency range of dc to 40 GHz; ability to maintain calibration integrity when changing connector types; and compatibility with all Type N, TNC, GPC-7, SMA, 2.92mm, and 2.4mm connectors used throughout the microwave industry.

What is a Ruggedized SMA Connector?

All Aeroflex / Weinschel SMA connectors labeled as ruggedized have a dielectric insulator at the interface of the connector to provide additional support for the center conductor during connects and disconnects and to keep out foreign material. This provides an important benefit--improved axial alignment of the center contact. This substantially reduces finger breakage of the female contact. Longevity of the Aeroflex / Weinschel SMA connector is enhanced because of the increased shoulder-wall thickness of the male connector shell. Typically, a standard SMA male connector shell has a 0.0065 inch wide shoulder. Compare that to 0.018 inch for the Aeroflex / Weinschel SMA series. The shoulder of most SMA male connectors gradually collapses from use. This causes the center contact to exceed the maximum height tolerance and eventually destroys the mating female contact. This will not happen with a Aeroflex / Weinschel SMA connector.

Model 1568 & 1568-1 Precision Coaxial Panel Adapters

dc to 26.5 GHz

Ruggedized SMA Connectors (female to female)



Features

- /// **High Repeatability.**
- /// **Rugged Injection Molded Connectors.**
- /// **Bulkhead Mounting** - Conveniently mounts on any panel using a D-hole shown below. Extra heavy construction for long life even with mistreatment makes this adapter suitable for instrument and subsystem front panel applications.

Specifications

NOMINAL IMPEDANCE: 50 Ω

FREQUENCY RANGE: dc to 26.5 GHz

MAXIMUM SWR:

Frequency (GHz)	SWR
dc - 18	1.15
18 - 26.5	1.20

INSERTION LOSS & REPEATABILITY (dB):

Frequency (GHz)	Ins Loss	Repeatability
dc - 12.4	< 0.30	0.01
12.4 - 18	< 0.40	0.02
18.0 to 26.5	< 0.50	0.02

TEMPERATURE RANGE: -55°C to +100°C

CONSTRUCTION: Inner and outer conductors: heat treated beryllium copper, gold plated. Mounting hardware provided (Hex nut and lockwasher) Add -1 to model number for the optional stainless steel body.

CONNECTORS: SMA connectors per MIL-STD-348 interface dimensions - mate nondestructively with MIL-C-39012 connectors.

WEIGHT: 56.7 g (2 oz) maximum

PHYSICAL DIMENSIONS:

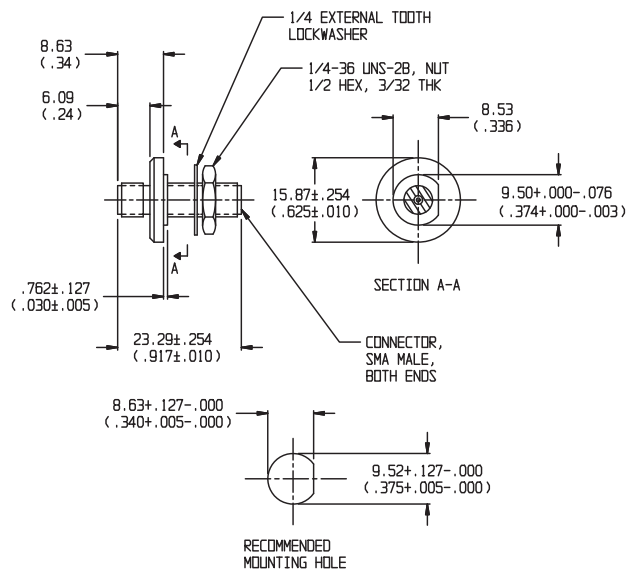

NOTE: All dimensions are given in mm (inches) and are maximum, unless otherwise specified.

Coaxial Adapters



Models 1587, 1588 & 1589 Precision Coaxial Adapters *Ruggedized SMA to SMA Connectors*

dc to 26.5 GHz

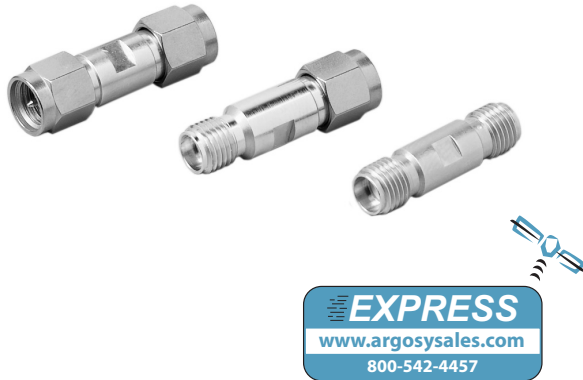

Features

- /// High Repeatability.
- /// Rugged Injection Molded Connectors.
- /// Designed for Measurement System Use - Auxiliary wrench flats aid in torquing connections without "chain reaction" loosening of multiple component hookups.

Specifications

NOMINAL IMPEDANCE: 50 Ω

FREQUENCY RANGE: dc to 26.5 GHz

MAXIMUM SWR:

Frequency (GHz)	SWR
dc - 18	1.15
18 - 26.5	1.20

INSERTION LOSS & REPEATABILITY (dB):

Frequency (GHz)	Ins Loss	Repeatability
dc - 12.4	< 0.30	0.01
12.4 - 18	< 0.40	0.02
18 to 26.5	< 0.50	0.02

TEMPERATURE RANGE: -55°C to +100°C

CONSTRUCTION: Inner and outer conductors: heat treated beryllium copper, gold plated.

CONNECTORS: SMA connectors per MIL-STD-348 interface dimensions - mate nondestructively with MIL-C-39012 connectors.

WEIGHT: 56.7 g (2 oz) maximum

PHYSICAL DIMENSIONS:

MODEL 1587:

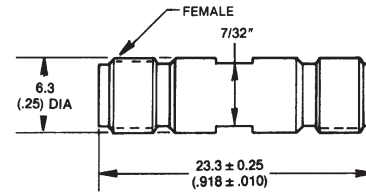

MODEL 1588:

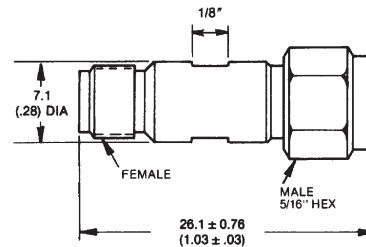

MODEL 1589:

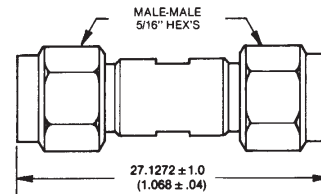

NOTE: All dimensions are given in mm (inches) and are maximum, unless otherwise specified.

Model 1513 Precision Coaxial Adapter Type N to Type N

dc to 18.0 GHz



Features

- /// Low SWR.
- /// High Repeatability.
- /// Stainless Steel Construction.

Specifications

NOMINAL IMPEDANCE: 50 Ω

FREQUENCY RANGE: dc to 18.0 GHz

MAXIMUM SWR:

Frequency (GHz)	SWR
dc - 10	1.10
10 - 18	1.15

INSERTION LOSS & REPEATABILITY (dB):

Frequency (GHz)	Maximum Ins Loss	Repeatability (Typical)
dc - 18	< 0.25	0.02

TEMPERATURE RANGE: -55°C to +85°C

CONSTRUCTION: Stainless Steel body, beryllium copper, gold plated contacts.

CONNECTORS: Type N per MIL-STD-348 interface dimensions - mate nondestructively with MIL-C-39012 connectors. Select model number as follows:

- Model M1513: male to male
- Model F1513: female to female

WEIGHT: Model M1513: 50 g (1.7 oz) maximum
Model F1513: 40 g (1.4 oz) maximum

PHYSICAL DIMENSIONS:

MODEL M1513:

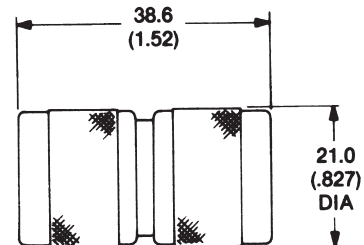

MODEL F1513:

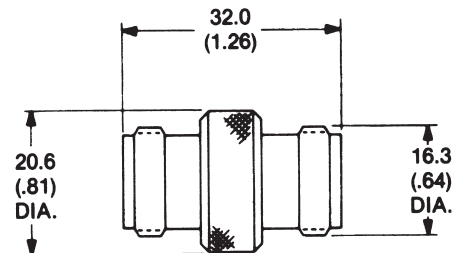

NOTE: All dimensions are given in mm (inches) and are maximum, unless otherwise specified.

Coaxial Adapters



Model 7002 High Performance Coaxial Adapter *Ruggedized SMA to Type N Connectors*

dc to 18.0 GHz

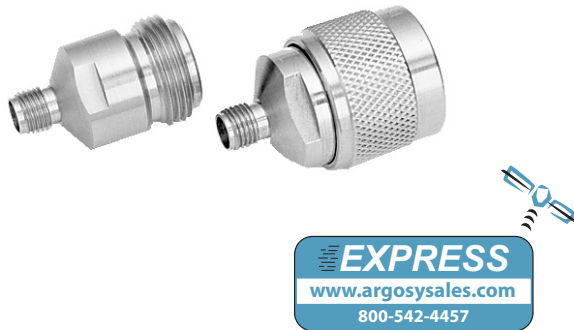

Features

- /// High Repeatability
- /// Rugged Injection Molded Connectors
- /// Stainless Steel Construction

Specifications

NOMINAL IMPEDANCE: 50 Ω

FREQUENCY RANGE: dc to 18.0 GHz

MAXIMUM SWR:

Frequency (GHz)	SWR (per adapter)
dc - 18	1.12

INSERTION LOSS & REPEATABILITY (dB):

Frequency (GHz)	Ins Loss*	Repeatability*
dc - 12.4	< 0.40	0.01
12.4 - 18	< 0.50	0.02

*Specification based on mated pair terminated in 50 Ω.

ELECTRICAL LENGTH:

Models 7002-14 & 7002-24: 33mm

Models 7002-13 & 7002-23: 20mm

CONSTRUCTION: Gold plated beryllium copper center conductors, injection molded into stainless steel outer bodies.

CONNECTORS: Type N and SMA connectors per MIL-STD-348 interface dimensions - mate nondestructively with MIL-C-39012 connectors.

WEIGHT: 30 g (1.1 oz) maximum

PHYSICAL DIMENSIONS:

MODEL 7002-13:

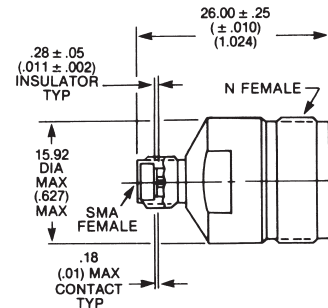

MODEL 7002-14:

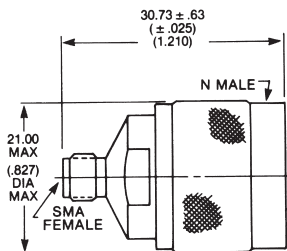

MODEL 7002-23:

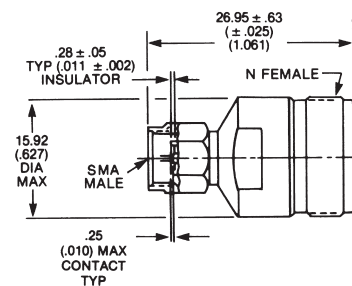

MODEL 7002-24:

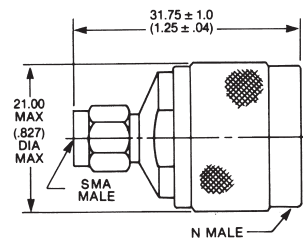

NOTE: All dimensions are given in mm (inches) and are maximum, unless otherwise specified.

Model 1548 Precision Coaxial Adapter SMA to Type N Connectors

dc to 18.0 GHz

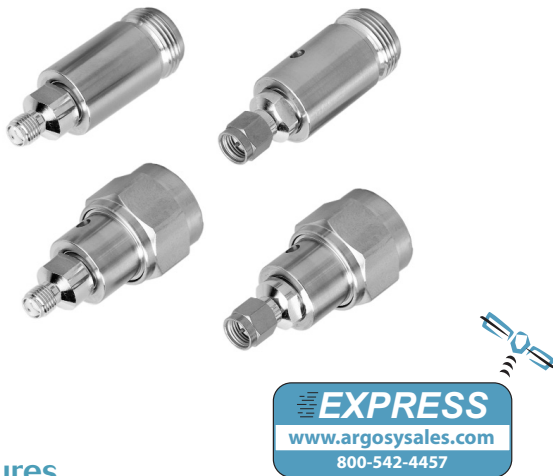

Features

- /// High Repeatability
- /// Rugged Construction
- /// Stainless Steel Construction

Specifications

NOMINAL IMPEDANCE: 50 Ω
FREQUENCY RANGE: dc to 18.0 GHz

PHYSICAL DIMENSIONS:

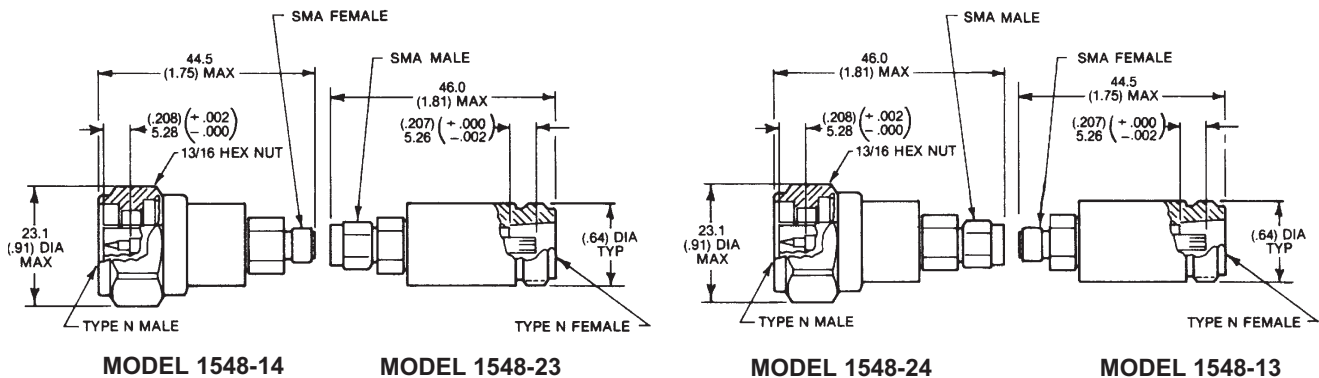

NOTE: All dimensions are given in mm (inches) and are maximum, unless otherwise specified.

MAXIMUM SWR:

Frequency (GHz)	SWR*
dc - 18	1.10

INSERTION LOSS (dB):

Frequency (GHz)	Loss (maximum)*
dc - 18	<0.43

REPEATABILITY (dB):

Frequency (GHz)	Type N	SMA
dc - 12.4	< 0.006	0.01
12.4 - 18	< 0.010	0.02

* Specification based on mated pair terminated in 50 Ω.

TEMPERATURE RANGE: -55°C to + 85°C

CONSTRUCTION: Stainless steel body and coupling nuts. Gold plated beryllium copper center conductors and SMA bodies, injection molded insulators. Coupling Torque: 14 ± 1 inch pounds for Type N and 8±0.5 inch pounds for SMA.

CONNECTORS: Type N and SMA connectors per MIL-STD-348 interface dimensions - mate nondestructively with MIL-C-39012 connectors.

WEIGHT: 56.7 g (2 oz) maximum connectors only.



Part Number 063-62

dc to 18.0 GHz

Precision 7mm Support Bead

Designed for N & 7mm Connectors & Airlines

RoHS



Specifications

NOMINAL IMPEDANCE: 50 Ω

FREQUENCY RANGE: dc to 18.0 GHz

MAXIMUM SWR:

Frequency (GHz)	SWR
dc - 2	1.004
2-18	1.004 + .0009*GHz

OPERATING TEMPERATURE: -50 ° to 120°C

CONSTRUCTION: Gold plated beryllium copper center conductors, injection molded into gold plated brass outer bodies.

WEIGHT: 0.7 g (0.025 oz)

Features

- /// High Temperature Operation
- /// Rugged Injection Molded Construction
- /// Captivated Insulator; prevents movement
- /// Excellent Matching
- /// Interchangeable with existing support beads

PHYSICAL DIMENSIONS:

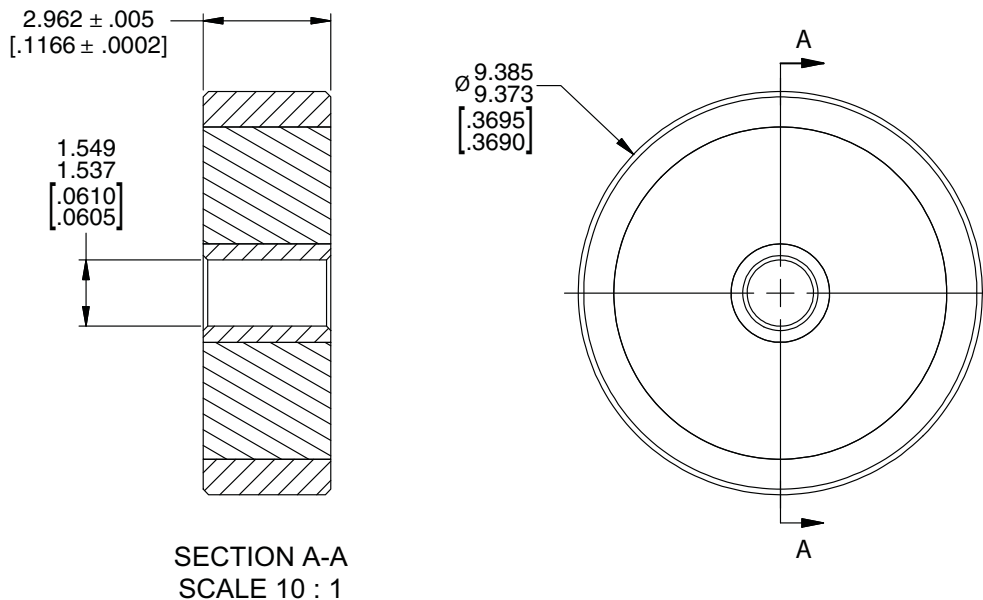

NOTE: All dimensions are given in mm (inches) and are maximum, unless otherwise specified.

Models 7008, 7034, 7035, 7035R & 7041 PLANAR BLIND-MATE® Connectors, dc to 40.0 GHz

Threadless Connector System / Space Saving / Long Life

AEROFLEX
A passion for performance.



Features

- /// **Threadless Connector Mating** - This blind-mate connector series provides threadless connector mating which is useful when mating an array of connectors on one RF module to another array within seconds.
- /// **Space Saving** - These connectors can simplify RF connections in the most inaccessible regions and high package density systems where conventional threaded connector mating is extremely difficult.
- /// **Long Life** - 1,000,000 typical matings. Excellent for ATE applications. Non-piloting spring loaded contact areas provided extremely long life and repeatability.
- /// **Connector Options** - Choose from many standard Connector options such as SMA per MIL-C-39012, SMK (2.92mm), 2.4mm and SMB.
- /// **Broad Frequency Range** - Aeroflex / Weinschel offers a wide selection of frequency ranges from dc to 40 GHz including most wireless bands.
- /// **Blind-Mate Fixed Attenuator, Termination & dc Block Designs** - Blind-mates can be configured on other coaxial products such as Fixed Attenuators, terminations and even dc blocks.
- /// **Ideal for mass-mount and receiver interface subsystems** where hundreds of high frequency connections need to be made simultaneously.
- /// **New Front & Rear Locking Models** - New designs offer front or rear mounting options.
- /// **Optimized Designs for RF & Wireless Applications**

Description

Planar Blind-mates connectors are typically used as a pair or set which is comprised of two connector subassemblies that have a common mating interface. Generally, a pair contains one floating blind-mate Interface with spring loaded inner/outer contacts and the other is a fixed blind-mate interface with fixed inner/outer contacts (Figure 1).

The Planar Blind-mate series provides threadless connector mating which is useful when mating an array of connectors on one RF module to another array within seconds. Each connector pair will tolerate typically 0.02 inches per pair radial and axial offset misalignment and still meet all of its electrical specifications.

Most Aeroflex / Weinschel Planar Blind-mates designs conveniently mount on any panel using a standard panel D-hole or most any standardized hole pattern. Extra heavy construction for long life even with mistreatment makes these blind-mate products suitable for panel use.

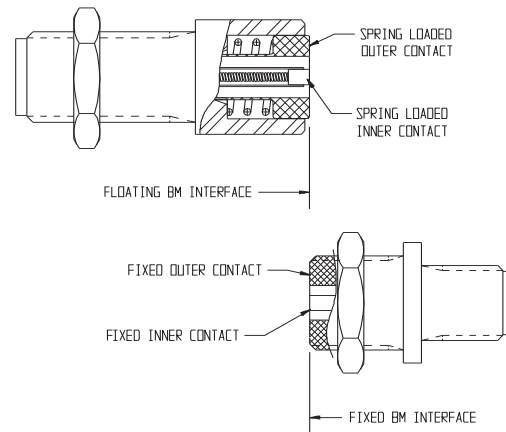

Figure 1. Common Blind-Mate Mating Interface

U.S. Patent Number 6,409,550

EXPRESS Shipment available via 800-542-4457 or www.argosysales.com. Check with distributor for current product stocking quantities.



AEROFLEX
WEINSCHTEL

Revision Date: 9/30/2012





Blind-Mate Connectors...dc-40.0 GHz

Model Number	Connector Type	Frequency Range (GHz)	SWR (Maximum)	Loss (Maximum dB)	Page No.	
♦ 7008	Pressurized SMA Female	dc - 40.0	1.30-1.65*	0.3-1.5*	188	
♦ 7034	2.92mm Female, Rear Lock, Floating	dc - 40.0	1.35-1.55*	0.50	189	
♦ 7034-1	2.92mm Female, Rear Lock, Fixed	dc - 40.0	1.35-1.55*	0.85		
♦ 7035	2.92mm Female, Front Locking Hex Nut, Floating	dc - 40.0	1.35-1.55*	0.50	190	
♦ 7035-1	2.92mm Female, Front Locking Hex Nut, Fixed	dc - 40.0	1.35-1.55*	0.85		
7035R	2.92mm Female, Front Locking, Floating, Round Nut	dc - 40.0	1.35-1.55*	0.85		
7035R-1	2.92mm Female, Front Locking, Fixed, Round Nut	dc - 40.0	1.35-1.55*	0.85		
7041	2.92mm Female, Rear Locking, Fixed, Round Nut, Lower Cost	dc - 18.0	1.20-1.40*	0.60	191	

♦ EXPRESS Shipment available via www.argosysales.com or 800-542-4457.
 Note: Other models may also be available from Express delivery.

* VARIES WITH FREQUENCY.

Applications

Ideal applications for these high quality/high frequency connectors range from mass-mount and receiver interface subsystems that house hundreds of high frequency connectors to single connector configurations. In either case these connectors allow threadless connector mating which is very useful when mating an array of connectors on one RF module to another array or connector within seconds.

Figure 2 shows a typical application where each connector half contains 7035R series connectors. These connectors contain spring loaded inner/outer contacts which allows for extremely long contact life as well as 0.02 per pair maximum radial and axial offset misalignment while still meeting all the specified electrical specifications.

Aeroflex / Weinschel offers a variety of standard models which are designed to fit or be configured into a wide range of applications:

- /// **Pressurized Designs** - Model 7008 (page 220) is equipped with a flange arrangement designed to withstand 1000 PSI of hydrostatic pressure. This model can be mated with another 7008 or any 7034 or 7035 series Planar Blind-mate. See page 218 for mating applications.
- /// **Rear Locking** - Models 7034 & 7034-1 (page 221) are beneficial in applications where there is easy access to the front of the connector for holding while the cable and connector is added or removed. Rotation is also prevented if the connector front is inserted in a slot which could allow for easier cable and connector assembly installation.
- /// **Front Locking** - Models 7035, 7035-1, 7035R, 7035R-1 (page 222) & 7041 (New..page 223) are beneficial in applications where the cable and connector will be inserted as an assembly into a panel or connector module from the rear.
- /// **Custom Configurations** - Other types of Planar Blind-mate connectors such as SMA, SMB, 3.5mm, flange, microstrip/pc board mount launch, test probes, frequency specific, arrays or interface subsystems can be designed for your particular application. Refer to page 222-224 for other examples.

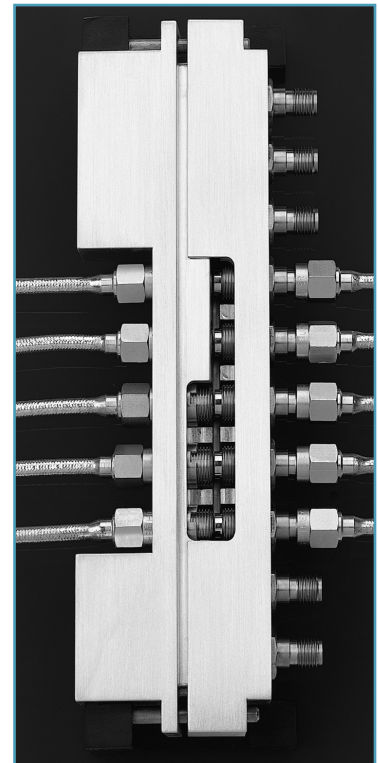
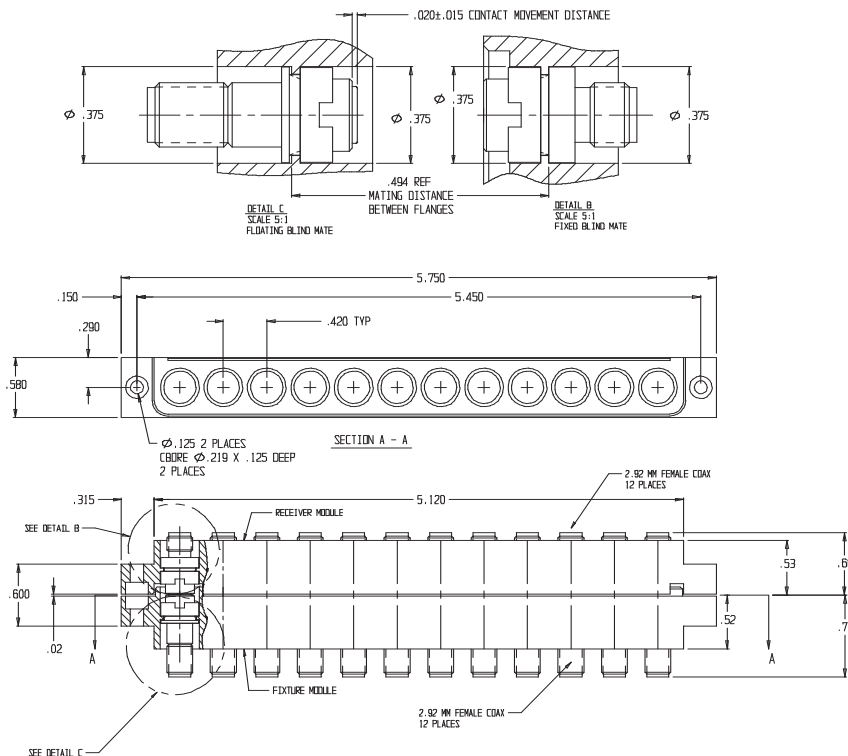

Figure 2. Typical Application

Model 7008
Pressurized PLANAR BLINDMATE® Connector

dc to 40.0 GHz



Specifications

NOMINAL IMPEDANCE: 50 Ω
FREQUENCY RANGE: dc to 40.0 GHz
POWER RATING: 50 Watts CW, 500 Watts peak

INSERTION LOSS (dB) & SWR*:

Frequency (GHz)	SWR		Loss	
	typical	maximum	typical	maximum
dc - 18	1.20	1.30	0.3	0.5
18 - 26.5	1.30	1.40	0.6	0.8
26.5 - 40	1.45	1.65	1.0	1.5

*Specifications are for mated pair (Mated pair can be any combination of Model 7008 and 7035).

Applications

Model 7034 & 7008:

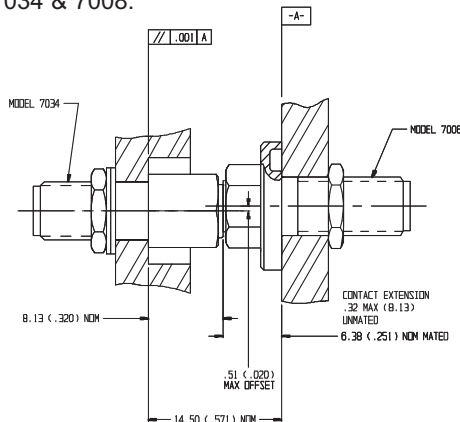

Model 7035 & 7008:

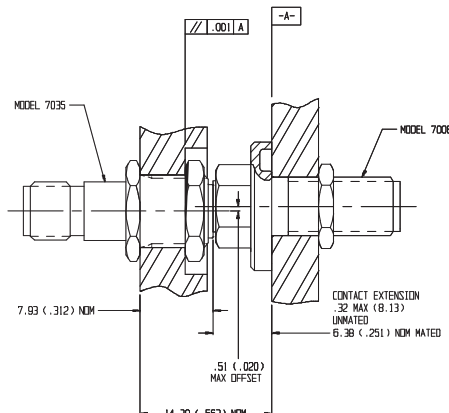

HYDROSTATIC PRESSURE: 1000 PSI
STATIC PRESSURE: 50 PSI
TEMPERATURE RANGE: -50°C to +125°C
CONNECTORS: Stainless Steel SMA connectors per MIL-STD-348 interface dimensions - mate nondestructively with MIL-C-39012 connectors.
WEIGHT: 2 oz (56.7 g) maximum
PHYSICAL DIMENSIONS:

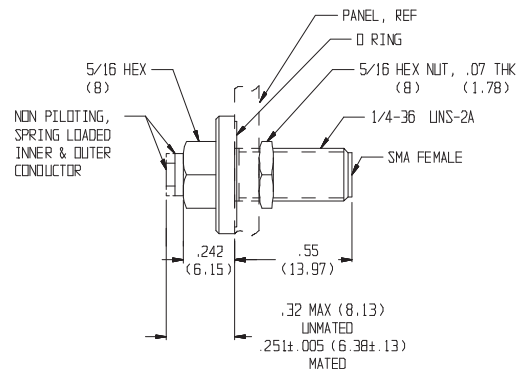

Model 7034-1 & 7008:

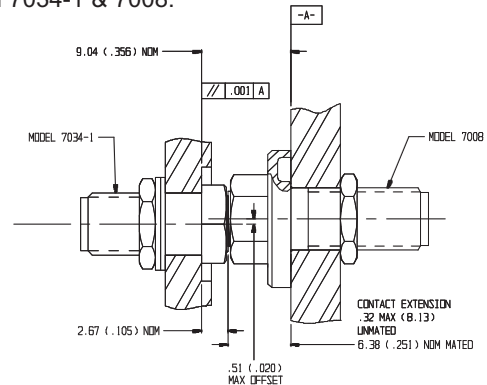

Model 7035-1 & 7008:

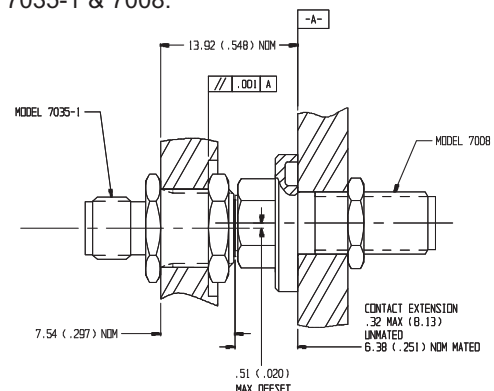

NOTE:

1. All dimensions are given in mm (inches) and are maximum, unless otherwise specified.
2. Unit available with RoHS compliant materials, specify when ordering.

Models 7034 & 7034-1 Rear Locking PLANAR BLINDMATE® Connectors

dc to 40.0 GHz



INSERTION LOSS (dB) & SWR:		
Frequency (GHz)	Loss (maximum)	SWR (maximum)
dc - 18	0.50	1.35
18 - 40	0.85	1.55

Specifications

- NOMINAL IMPEDANCE:** 50 Ω
- FREQUENCY RANGE:** dc to 40.0 GHz
- INSERTION LOSS REPEATABILITY:** ±0.1 dB typical
- MECHANICAL LIFE:** 25,000 matings minimum

- RADIAL OFFSET ALLOWED:** ±0.02 inches per pair
- TEMPERATURE RANGE:** -50°C to +100°C
- CONNECTORS:** Stainless Steel 2.92mm connector with gold plated contacts - mate nondestructively with SMA connectors per MIL-C-39012, 3.5mm, SMK, and other 2.92mm connectors.
- WEIGHT:** 2 oz, (56.7 g) maximum

PHYSICAL DIMENSIONS:

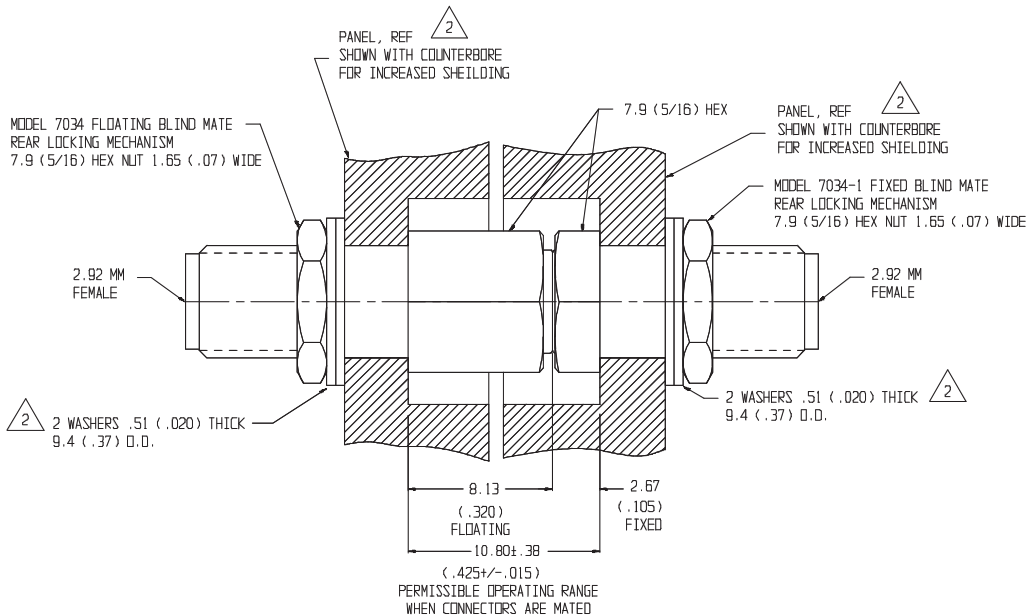

- NOTES:
- All dimensions are given in mm (inches) and are nominal, unless otherwise specified.
 - Maximum panel thickness for Model 7034 is 4.9 (0.195). For panels less than 4.2 (0.165) installation requires appropriate washer.
 - Unit available with RoHS compliant materials, specify when ordering.

Models 7035, 7035-1, 7035R & 7035R-1 dc to 40.0 GHz Front Locking PLANAR BLINDMATE® Connectors **RoHS**



INSERTION LOSS (dB) & SWR:

Frequency (GHz)	Loss (maximum)	SWR (maximum)
dc - 18	0.50	1.35
18 - 40	0.85	1.55

Specifications

NOMINAL IMPEDANCE: 50 Ω
FREQUENCY RANGE: dc to 40.0 GHz
INSERTION LOSS REPEATABILITY: ±0.1 dB typical
MECHANICAL LIFE: 25,000 matings minimum

PHYSICAL DIMENSIONS:

Models 7035 & 7035-1:

RADIAL OFFSET ALLOWED: ±0.02 inches per pair
TEMPERATURE RANGE: -50°C to +100°C
CONNECTORS: Stainless Steel 2.92mm connector with gold plated contacts - mate nondestructively with SMA connectors per MIL-C-39012, 3.5mm, SMK, and other 2.92mm connectors.
WEIGHT: 2 oz (56.7 g) maximum

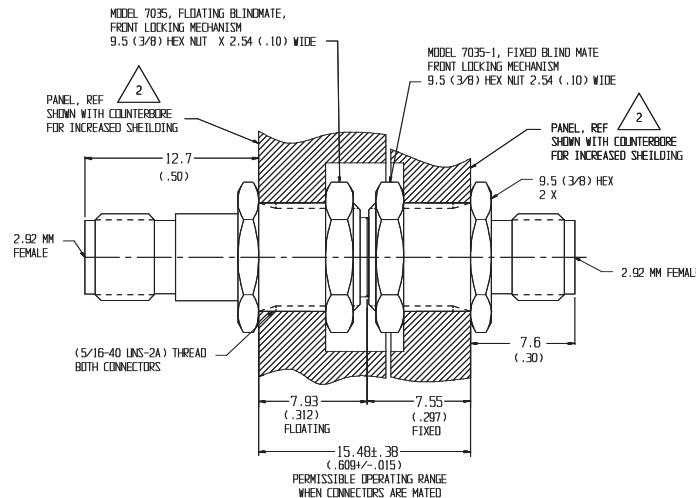

Models 7035R & 7035R-1:

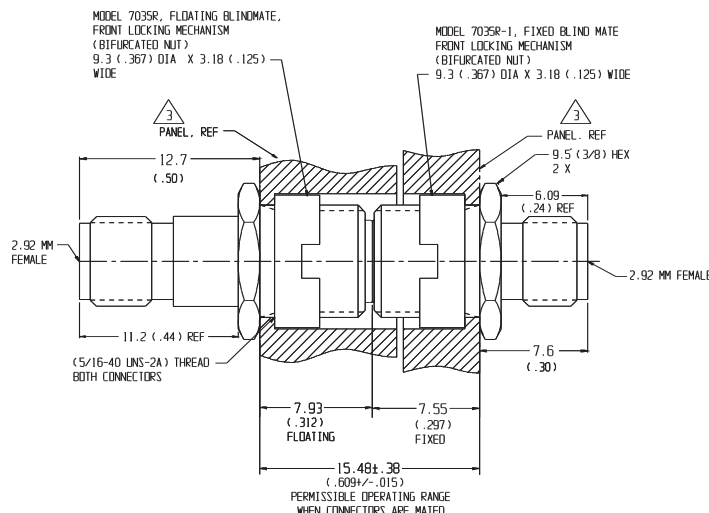

- NOTES:
1. All dimensions are given in mm (inches) and are nominal, unless otherwise specified.
 2. Maximum panel thickness for Model 7035 is 4.9 (0.195).
 3. Panel flange thickness of 1.0 (0.03) shown for 7035R. Connector Mating shown with counterbore for increased shielding effectiveness.
 4. Unit available with RoHS compliant materials, specify when ordering

Models 7041 Rear Locking PLANAR BLINDMATE® Connector Lower Cost Design

dc to 18.0 GHz



Specifications

NOMINAL IMPEDANCE: 50 Ω nominal
FREQUENCY RANGE: dc to 18.0 GHz

INSERTION LOSS (dB) & SWR:

Frequency (GHz)	Loss (maximum)	SWR (maximum)
dc - 6	0.40	1.20
6 - 18	0.60	1.40

INSERTION LOSS

REPEATABILITY: ±0.1 dB typical

MECHANICAL LIFE: 25,000 matings minimum

RADIAL OFFSET ALLOWED: ±0.02 inches per pair

TEMPERATURE RANGE: -50°C to +100°C

CONNECTORS: Stainless Steel 2.92mm connector with gold plated contacts - mate nondestructively with SMA connectors per MIL-C-39012, 3.5mm, SMK, and other 2.92mm connectors.

WEIGHT: 2 oz, (56.7 g) maximum

PHYSICAL DIMENSIONS:

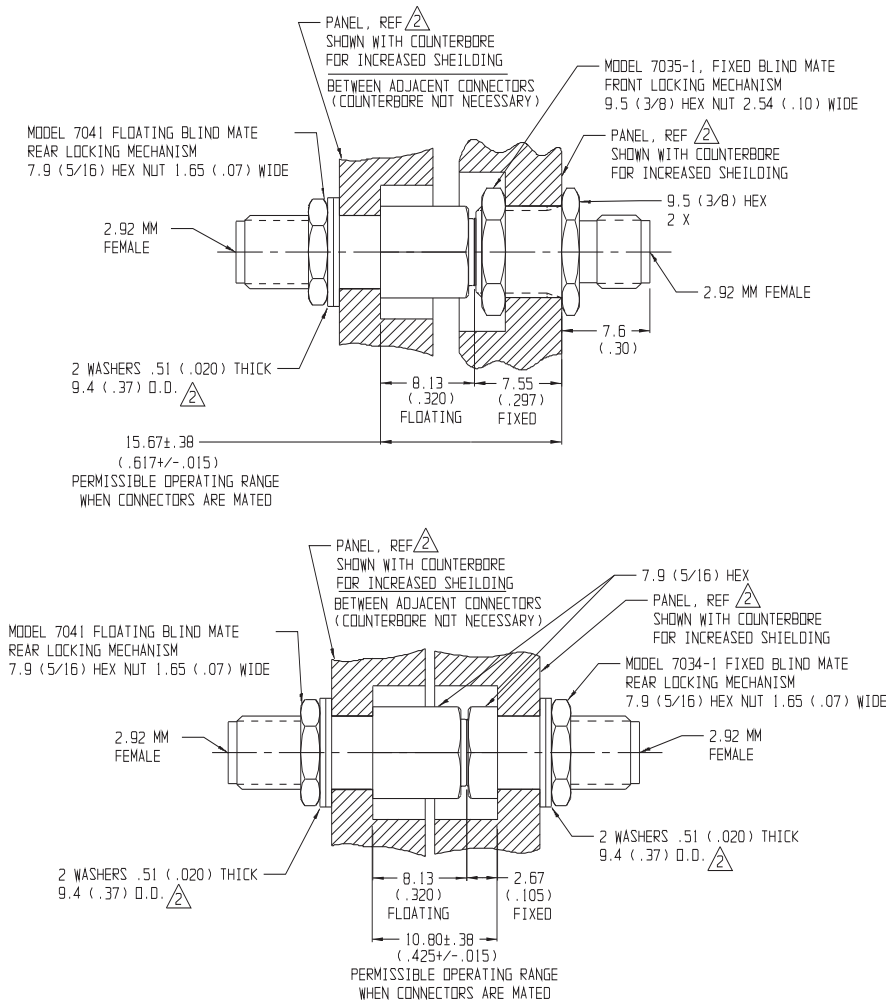

- NOTES: 1. All dimensions are given in mm (inches) and are nominal, unless otherwise specified.
2. Maximum panel thickness for Model 7041 is 4.9 (0.195). Panel flange thickness less than 4.2 (0.165). Installation requires appropriate washer.
3. * when mating surface have been maintained and kept clean.

Custom Examples

The following examples illustrate some typical Blind-mate designs that can be either modified or used as a basis for creating a specific blind-mate connector or system for your application:

Example 1:

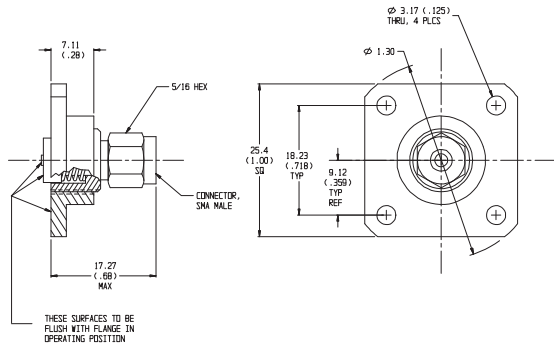

This example shows a blind-mate to SMA flange connector which includes a standard 4 hole mounting pattern and SMA connectors per MIL-C-39012 connectors. These connectors can be optimized to a specific frequency range and/or your defined specifications.

Example 2:

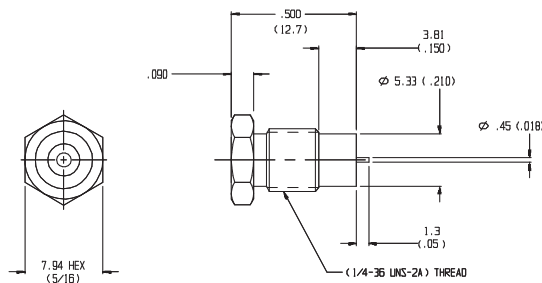

Example 2 illustrates a blind-mate to a microstrip launch design that features a non-piloting (fixed), spring loaded inner connector. Specifications include dc to 4 GHz frequency operation, maximum insertion loss of 0.5 dB and maximum SWR of 1.25.

Example 3:

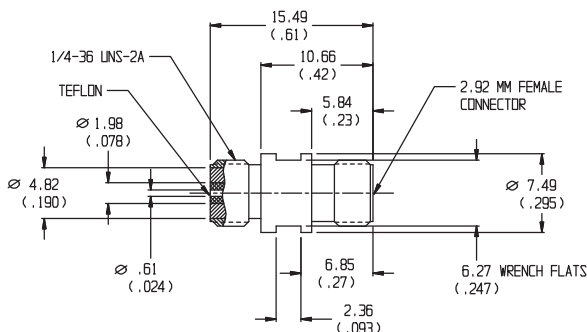

Example 3 illustrates a blind-mate to 2.92mm test probe design that features wrench flats, dc to 18 GHz frequency operation, maximum insertion loss of 6 dB and maximum SWR of 1.25. This was specifically designed to interface with standard SMA, 3.5mm, and 2.92mm Bulkhead connectors.

Example 4:

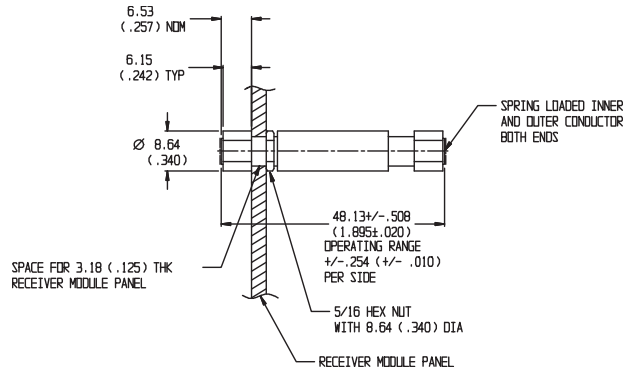

This example illustrates shows a 6 dB blind-mate attenuator design that consists of two floating receivers with a compression spring and spring loaded contacts (inner and outer conductors). Designs can also be supplied with stationary fixed surface connectors. Specifications for this unit include dc-32 GHz operation, 1.35 maximum SWR, and a radial alignment ± 0.02 offset.

Example 5:

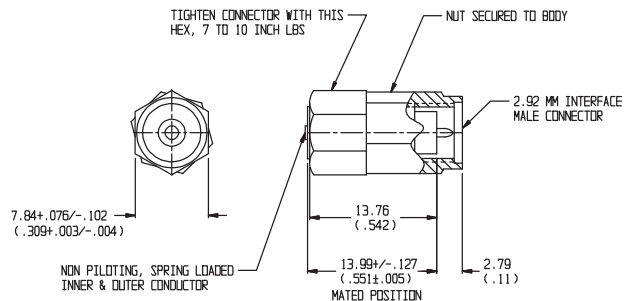

This example illustrates a blind-mate to 2.92mm connector design that features a non-piloting, spring loaded inner and outer connector. Specifications included dc to 40 GHz frequency operation, static pressure of 50 PSI, temperature range of -50°C to +125°C maximum insertion loss of 0.3 to 1.5 and maximum SWR of 1.30-1.70.

Example 6:

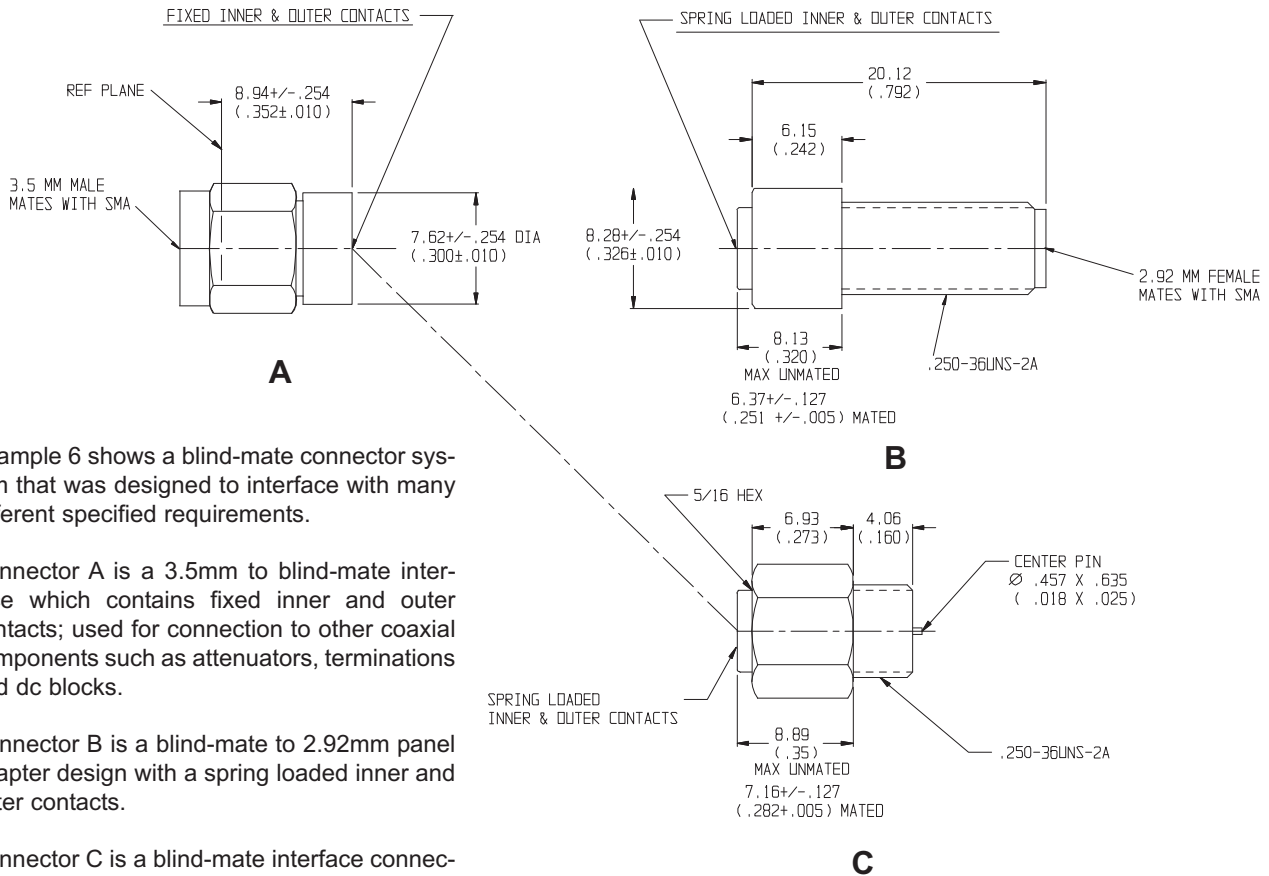

Example 6 shows a blind-mate connector system that was designed to interface with many different specified requirements.

Connector A is a 3.5mm to blind-mate interface which contains fixed inner and outer contacts; used for connection to other coaxial components such as attenuators, terminations and dc blocks.

Connector B is a blind-mate to 2.92mm panel adapter design with a spring loaded inner and outer contacts.

Connector C is a blind-mate interface connector that can be easily installed to coaxial cables or printed circuit board assemblies.

Example 7:

This example illustrates a low cost blind-mate to SMB configuration specifically designed and optimized for RF & wireless applications. These connectors offer not only all the features of the Planar Blind-mate interface but the SMB connector provides an additional quick disconnect for cable assemblies.

Specifications for this connector include dc to 2.0 GHz operation, 50 Ω nominal impedance, insertion loss of 0.35 dB, SWR of 1.15-1.30, radial/axial misalignment of ±0.020" OFFSET (blind-mate side), **operating temperature of +10°C to +40°C**, dielectric withstanding voltage of 1000 Vac and a insulation resistance of **1000 MΩ nominal**.

These stainless steel connectors contain non-piloting contacts that provides long life (1,000,000 matings) and offers a repeatability of ±0.05 dB typical.

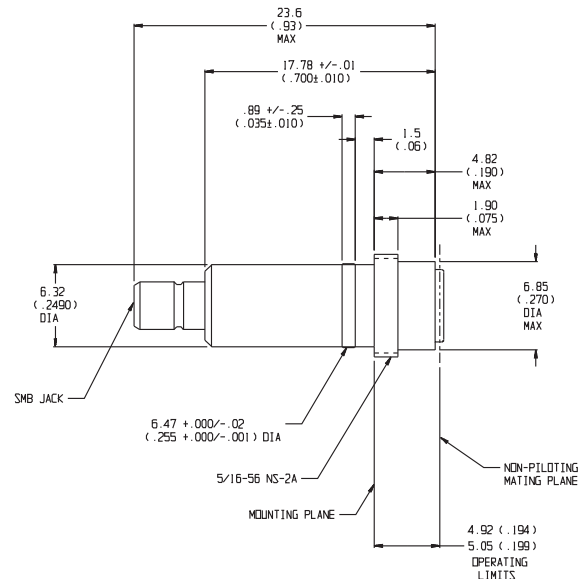

NOTE: All dimensions are given in mm (inches) and are maximum, unless otherwise specified.

Models 7004A & 7005A

PLANAR CROWN® UNIVERSAL CONNECTOR SYSTEM dc to 40.0 GHz

SMA; Type N; TNC; GPC-7; 3.5mm; SMK; 2.4mm

AEROFLEX
A passion for performance.



 **RoHS**

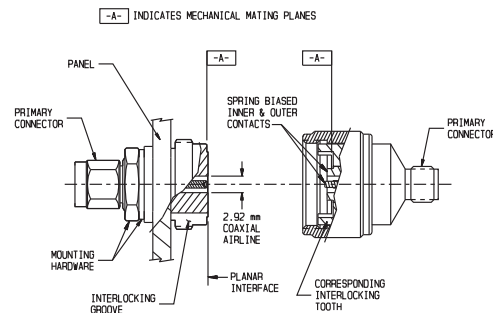

Features

The use of PLANAR CROWN® connectors on instruments, cables, components/accessories offers the manufacturer and user the following benefits.

Reduced Downtime - Damaged connectors can be replaced in seconds without any tools. Repair cost is minimized to that of a single connector. Recalibration, in most applications, is virtually eliminated due to closely matched phase, mechanical dimensions and insertion loss of the replaceable PLANAR CROWN® assemblies.

Versatility - Ability to select different connector types adds versatility to instruments, cables, systems and accessories. It offers the end user multiple connector options. Connector type and sex can be readily interchanged as dictated by the system/DUT, eliminating the need for adapters.

Superior Electrical Performance than would be obtained by additional adapters.

Simplified Network and Power Measurements on non-insertable devices.

Non-rotational Interface - Since the PLANAR INTERFACE has interlocking teeth, it eliminates unthreading of the connection when the Crown is subjected to a rotational torque. This feature is especially useful on coaxial cables where one end unthreads so easily when the cable is subjected to twisting or flexing.

Torque Independent Connection - A torque wrench is not required when mating the Crown to the bulkhead. A reasonable hand tightening of the coupling nut results in an excellent RF connection. This is achieved by having spring biased inner and outer contacts in the Crown connectors. Spring biasing ensures an intimate electrical contact at the PLANAR INTERFACE. A pilot diameter on the bulkhead guarantees excellent concentricity.

Axial Isolation of the Center Contact - Any excessive axial force on the Crown center contact is absorbed by the spring biasing at the Planar interface end.

Standardized Mounting Holes - All instrument panels can be fabricated with a standard 3/8" Dia. D-hole independent of the front panel connector type/sex. This eliminates changes in sheet metal design when different connector options are requested.

Description

The PLANAR CROWN® UNIVERSAL CONNECTOR SYSTEM is comprised of two connector halves/subassemblies which have a common mating interface referred to as the PLANAR INTERFACE. The first connector half is called the PLANAR BULKHEAD which readily mounts into instrument front panels, components and cables. One end of this bulkhead has a 2.92mm (SMK) male/female primary connector. The other end has a combination of grooves, external threads and a coaxial PLANAR INTERFACE with a 2.92mm (SMK) airline geometry. The bulkhead operates mode free beyond 40 GHz. The second connector half, called the PLANAR CROWN®, has a similar 2.92mm PLANAR INTERFACE on one end, with spring biased inner and outer contacts. It has corresponding projections which interlock with slots on the bulkhead and a coupling nut which secures the two connector halves, resulting in a non-rotational, torque independent electrical connection. The spring biased inner and outer contacts eliminate the need for specifying proof torque and no tools are required to mate or unmate or break the connection. The primary end of the PLANAR CROWN® is offered in a variety of primary coaxial connector configurations such as SMA, Type N, GPC-7, TNC, 3.5mm, 2.92mm (SMK) and 2.4mm (under development), thus providing an extremely versatile connector system wherein a connector can be replaced in a matter of seconds.

EXPRESS Shipment available via 800-542-4457 or www.argosysales.com. Check with distributor for current product stocking quantities.

AEROFLEX
WEINSCHEL

Specifications



PLANAR BULKHEAD CONNECTORS

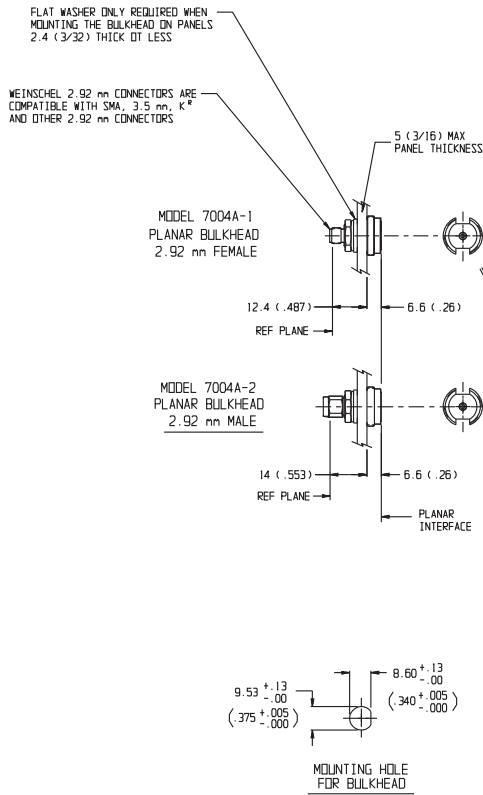



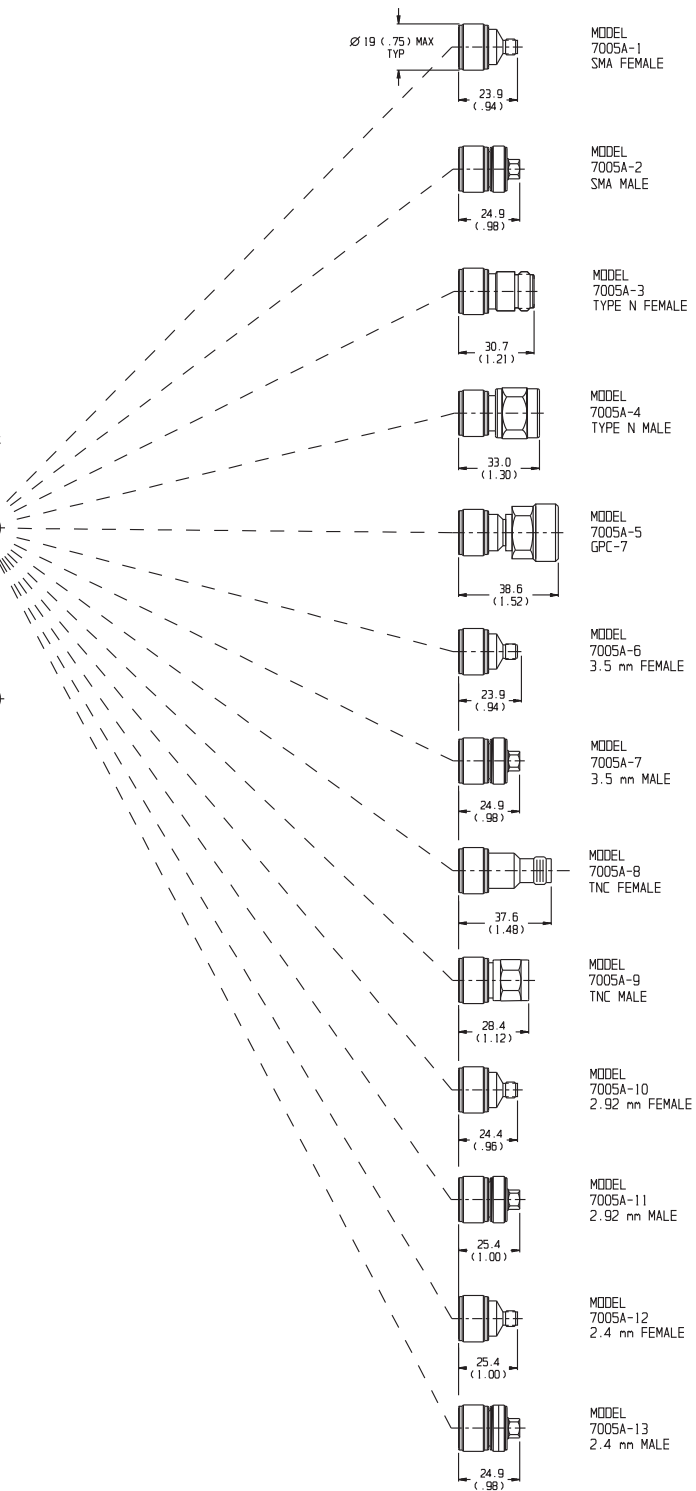

PLANAR CROWN CONNECTORS















U.S. Patent No. 4,836,801
(Other U.S. and Foreign Patents pending)

- NOTES: 1. All dimensions are given in mm (inches) and are nominal, unless otherwise specified.
2. K[®] is a registered trademark of the Wiltron 2.92mm connector
3. Unit available with RoHS compliant materials, specify when ordering.

PLANAR BULKHEAD Connectors . . . dc to 40.0 GHz

Model Number/ Primary Conn.	Frequency Range (GHz)	SWR* (maximum)	Insertion Loss * (dB maximum)	Electrical Length	
★ 7004A-1 2.92mm Female	dc - 40	----	----	19.9 ± 0.25mm	
★ 7004A-2 2.92mm Male	dc - 40	----	----	21.6 ± 0.25mm	
7010-1 2.92mm Female with dc Block	dc - 26.5	1.20-1.25	0.6-0.9	19.9 ± 0.25mm	
7010-2 2.92mm Male with dc Block	dc - 26.5	1.20-1.25	0.6-0.9	21.6 ± 0.25mm	

PLANAR CROWN Connectors . . . dc to 40.0 GHz

Model Number/ Primary Conn.	Frequency Range (GHz)	SWR* (maximum)	Insertion Loss * (dB maximum)	Electrical Length	
7005A-1 SMA Female	dc - 26.5	1.20 (dc -18 GHz) 1.25 (18 - 26.5 GHz)	0.25 (dc -18 GHz) 0.35 (18 - 26.5 GHz)	18.6 ± 0.25mm	
7005A-2 SMA Male	dc - 26.5	1.20 (dc -18 GHz) 1.25 (18 - 26.5 GHz)	0.25 (dc -18 GHz) 0.35 (18 - 26.5 GHz)	18.6 ± 0.25mm	
★ 7005A-3 Type N Female	dc - 18	1.20	0.25	18.6 ± 0.25mm	
★ 7005A-4 Type N Male	dc - 18	1.20	0.25	28.6 ± 0.25mm	
7005A-5 GPC-7	dc - 18	1.20	0.25	34.8 ± 0.25mm	
★ 7005A-6 3.5mm Female	dc - 34	1.20 (dc -18 GHz) 1.25 (18 - 26.5 GHz) 1.30 (26.5 - 34 GHz)	0.25 (dc -18 GHz) 0.35 (18 - 34 GHz)	18.0 ± 0.20mm	
★ 7005A-7 3.5mm Male	dc - 34	1.20 (dc -18 GHz) 1.25 (18 - 26.5 GHz) 1.30 (26.5 - 34 GHz)	0.25 (dc -18 GHz) 0.35 (18 - 34 GHz)	18.0 ± 0.20mm	
★ 7005A-8 TNC Female	dc - 18	1.20	0.25	26.3 ± 0.35mm	
7005A-9 TNC Male	dc - 18	1.20	0.25	26.3 ± 0.35mm	
★ 7005A-10 2.92mm Female	dc - 40	1.20 (dc -18 GHz) 1.25 (18 - 26.5 GHz) 1.35 (26.5 - 40 GHz)	0.25 (dc -18 GHz) 0.35 (18 - 26.5 GHz) 0.45 (26.5 - 40 GHz)	18.0 ± 0.15mm	
7005A-11 2.92mm Male	dc - 40	1.20 (dc -18 GHz) 1.25 (18 - 26.5 GHz) 1.35 (26.5 - 40 GHz)	0.25 (dc -18 GHz) 0.35 (18 - 26.5 GHz) 0.45 (26.5 - 40 GHz)	18.0 ± 0.15mm	
7005A-12 2.4mm Female	dc - 40	1.20 (dc -18 GHz) 1.25 (18 - 26.5 GHz) 1.35 (26.5 - 40 GHz)	0.25 (dc -18 GHz) 0.35 (18 - 26.5 GHz) 0.45 (26.5 - 40 GHz)	18.0 ± 0.15mm	
7005A-13 2.4mm Male	dc - 40	1.20 (dc -18 GHz) 1.25 (18 - 26.5 GHz) 1.35 (26.5-40 GHz)	0.25 (dc -18 GHz) 0.35 (18 - 26.5 GHz) 0.45 (26.5-40 GHz)	18.0 ± 0.15mm	

Notes: 1. Specifications based on mated pair of **7004A-X** and **7005A-XX**. Refer to mating PLANAR CROWN for SWR and Insertion loss specifications.
2. Aeroflex / Weinschel 2.92mm connectors are compatible with SMA, 3.5mm, SMK and other 2.92mm connectors.

General Specifications

PLANAR INTERFACE REPEATABILITY¹:

Reflection Coefficient (Magnitude):

60 dB (dc - 18 GHz)
50 dB (18 - 26.5 GHz)
45 dB (26.5 - 40 GHz)

Transmission (Magnitude)²:

40 dB (dc - 18 GHz)
35 dB (18 - 26.5 GHz)
30 dB (26.5 - 40 GHz)

Transmission (phase)²: 0.5°

1. The Repeatability specifications apply to ten consecutive disconnections and reconnections of the PLANAR INTERFACE.
2. Transmission repeatability includes the repeatability of the VNA test cable.

OPERATING TEMPERATURE: 0°C to 85°C

CONSTRUCTION: Passivated stainless steel bodies and coupling nuts. Gold plated beryllium copper contacts.

INTERFACE DIMENSIONS & ADDITIONAL FEATURES OF PRIMARY CONNECTORS:

SMA (Models 7005A-1 and -2):

Contact Pin Recession: 0 to 0.1mm (0 to 0.004 in)

Front Insulator Recession: 0.23 to 0.33mm (0.009 to 0.013 in)

Aeroflex / Weinschel high frequency **SMA** connector operates mode free beyond 26.5 GHz and is a superior SMA connector. It incorporates a wider shoulder on the male and female mating planes (0.020" typical compared to 0.007" on standard SMA connectors) and has a 3 slot female contact instead of the conventional four slot design. Both these features result in a **more rugged** connector with longer life and improved repeatability. Unlike many commercial teflon loaded SMA connectors, these connectors will not cause premature damage when mated with 3.5mm, 2.92mm and K[®] connectors.

Type N (Models 7005A-3 and -4):

Contact Pin Protrusion (N female): 5.18 to 5.26mm (0.204 to 0.207 in)

Contact Pin Recession (N Male): 5.28 to 5.36mm (0.208 to 0.211 in)

The male and female Type N connectors are Precision Test connectors per MIL-STD-348. They are usable to 22 GHz.

GPC-7 (Model 7005A-5):

Contact Pin Recession: 0 to 0.05mm (0 to 0.002 in)

The GPC-7 connectors are designed per IEEE Std 287.

3.5mm (Models 7005A-6 and -7):

Contact Pin Recession: 0 to 0.08mm (0 to 0.003 in)

TNC (Models 7005A-8 and -9):

Contact Pin and Insulator Protrusion (TNC Female): 5.03 to 5.28mm (0.198 to 0.208 inch)

Contact Pin and Insulator Recession: 5.28mm (0.208 in) minimum

These TNC male and female connectors are designed per MIL-STD-348 interface requirements for the NEW TNC connectors and operate mode free beyond 18 GHz.

2.92mm (Models 7005A-10 and -11):

Contact Pin Recession: 0 to 0.08mm (0 to 0.003 in)

In addition to the many advantages of 2.92mm airline connectors the Aeroflex / Weinschel version incorporates a three slot female contact design resulting in a more ruggedized contact than the conventional four slot design on most 2.92mm connectors.

2.4mm (Models 7005A-12 and 7005A-13):

Contact Pin Recession: 0 to 0.08mm (0 to 0.003 in)

Applications

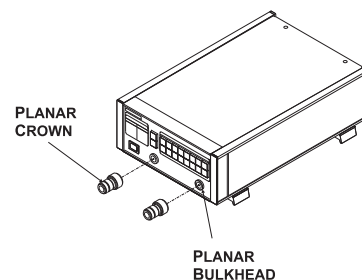

Test Instruments - Synthesizers; network/spectrum analyzers, power meters and many more.

Accessories - Detectors, SWR bridges/auto testers; power sensors, etc.,

Microwave Cables - Cables constructed with the **PLANAR BULKHEAD** connector interface at one end offer the user a wide choice of primary coaxial connectors offered on the **PLANAR CROWN** models. For an instrument such as a VNA, this eliminates the need for having different sets of test cables for different connector configurations. Cables with a built in **PLANAR CROWN** on the opposite end mate directly with **PLANAR BULKHEADS** on instruments, providing an excellent non-rotational electrical connection.

Special Configurations - The **PLANAR BULKHEAD** design can be provided with a built in attenuator or dc block. This is a useful feature when instrument front ends require a masking attenuator or need to be protected against dc voltages. Although the basic mechanical design of the **PLANAR BULKHEAD** was intended for panel mounting, it can be modified to mount directly into other accessories. The primary connector of the bulkhead can also be modified to launch directly on microstrip or suspended stripline substrates.

Programmable Attenuators & Attenuator/Switch Controllers



- /// Widest Selection of Attenuation Ranges & Steps Sizes
- /// **Express** shipment available on select models.
- /// Built-In TTL\CMOS Interface Driver Circuitry available.
- /// High Quality Construction & Connectors
- /// Special Configurations Available Upon Request
 - Custom Cell/Step Size Configurations
 - Higher Frequencies

General Information

In this section of the catalog, each Programmable Attenuator is outlined utilizing individual data sheets containing product features, specifications, and outline drawings. These data sheets are preceded by a quick reference guide to help you select the Programmable Attenuator(s) that fits your needs. The page number for each Programmable Attenuator data sheet is given in the quick reference guide.

This section includes all available accessories for the Aeroflex / Weinschel programmable attenuators such as our Model 8210A Attenuator / Switch Controller, product specific driver boards, and our programmable attenuators with our built-in microprocessor-based drivers. Also Included in this section are Aeroflex / Weinschel's wide variety of programmable attenuator units which includes the 8310, 8311 and 8312 series. Other subsystem solutions can be located in the Subsystem and Accessories section (pg 135).

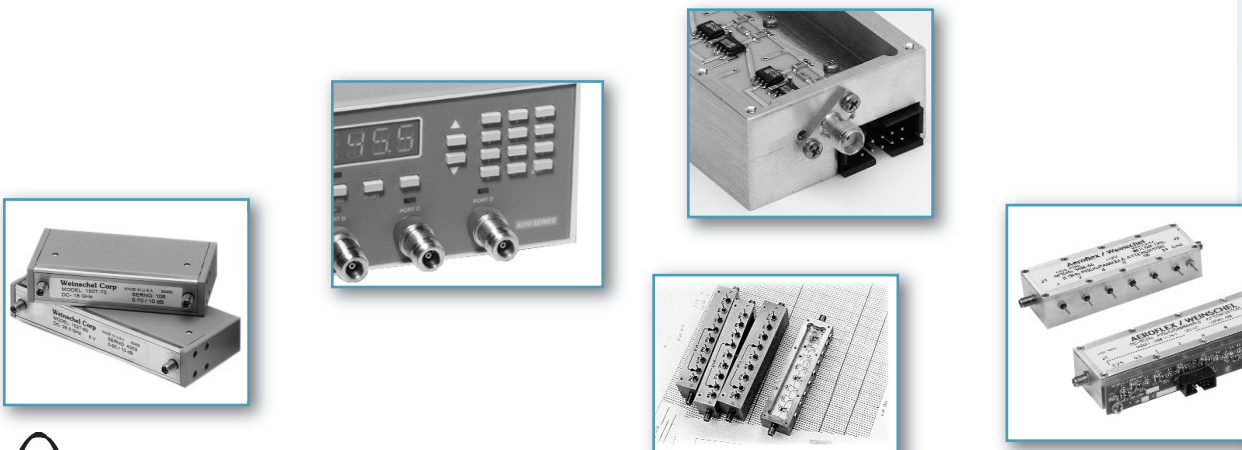

NOTE: **EXPRESS** Shipment available via www.argosysales.com or 800-542-4457. Check with distributor for current product stocking quantities.



Relay Switched Programmable Attenuators, Basic Models . . . DC-6 GHz





Model Number	Frequency Range (GHz)	Attenuation Range (dB)	Step Size (dB)	Insertion Loss, Max. (dB)	Maximum SWR	Connector Type	Average Power (Watts)	Peak Power (Watts)	Page No.
• 3200-1E	dc-3.0	0-127	1	4.70	1.30-1.40*	SMA	1	50	209
• 3200-2E		0-63.75	0.25	4.70	1.30-1.40*				
3201-1E		0-31	1	3.25	1.25-1.40*				
3205-1E		0-70	10	2.60	1.25-1.40*				
3205-2E		0-55	5	2.60	1.25-1.40*				
3205-3E		0-1.5	0.1	2.60	1.25-1.40*				
3206-1E		0-63	1	3.70	1.25-1.35*				
3209-1E		0-64.5	0.1	5.50	1.35-1.45*				
3404-15	dc-6.0	0-15	1	2.60	1.30-1.45*	SMA	1	50	218
3404-55		0.55	5	2.60					
3404-70		0-70	10	2.60					
3406-55		0-55	1	3.80					
3408-55.75		0-55.75	0.25	5.00					
3408-103		0-103	1	5.00					

Relay Switched Programmable Attenuators, with built-in Microprocessor-Base Driver . . . DC-6 GHz (For use with Aeroflex / Weinschel 8210A Controller)



Model Number	Frequency Range (GHz)	Attenuation Range (dB)	Step Size (dB)	Insertion Loss, Max. (dB)	Maximum SWR	Connector Type	Average Power (Watts)	Peak Power (Watts)	Page No.
3200T-1E	dc-3.0	0-127	1	4.70	1.30-1.40*	SMA	1	50	215
3200T-2E		0-63.75	0.25	4.70	1.30-1.40*				
3201T-1E		0-31	1	3.25	1.25-1.40*				
3205T-1E		0-70	10	2.60	1.25-1.40*				
3205T-2E		0-55	5	2.60	1.25-1.40*				
3205T-3E		0-1.5	0.1	2.60	1.25-1.40*				
3206T-1E		0-63	1	3.70	1.25-1.35*				
3209T-1E		0-64.5	0.1	5.50	1.35-1.45*				
3404T-15	dc-6.0	0-15	1	2.60	1.30-1.45*	SMA	1	50	222
3404T-55		0.55	5	2.60					
3404T-70		0-70	10	2.60					
3406T-55		0-55	1	3.80					
3408T-55.75		0-55.75	0.25	5.00					
3408T-103		0-103	1	5.00					

* VARIES WITH FREQUENCY.

- EXPRESS Shipment available via www.argosysales.com or 800-542-4457. Check with Distributor for other available models.

Programmable Attenuators



Relay Switched Programmable Attenuators, with built-in Microprocessor-Based Driver . . . dc - 26.5 GHz (For use with Aeroflex / Weinschel 8210A Controller)



Model Number	Frequency Range (GHz)	Attenuation Range (dB)	Step Size (dB)	Insertion Loss, Max. (dB)	Maximum SWR	Connector Type	Average Power (Watts)	Peak Power (Watts)	Page No.
150T-11	dc-18.0	0-11	1	2.2	1.50-1.90*	3.5mm	1	100	224
150T-15		0-15	1	2.2	1.50-1.90*				
150T-31		0-31	1	2.6	1.50-1.90*				
150T-62		0-62	2	2.6	1.50-1.90*				
150T-70		0-70	10	2.6	1.35-1.70*				
150T-75		0-75	5	2.2	1.50-1.90*				
150T-110		0-110	10	2.2	1.50-1.90*				
151T-11	dc-4.0	0-11	1	0.9	1.50	3.5mm	1	100	224
151T-15		0-15	1	0.9	1.50				
151T-31		0-31	1	0.9	1.50				
151T-62		0-62	2	1.1	1.50				
151T-70		0-70	10	0.7	1.35				
151T-75		0-75	5	0.9	1.50				
151T-110		0-110	10	0.9	1.50				
152T-55	dc-26.5	0-55	5	2.98	1.40-1.90*	3.5mm	1	100	224
152T-70		0-70	10	2.98	1.40-1.90*				
152AT-70		0-70	10	2.98	1.40-1.90*				
152T-75		0-75	5	2.98	1.40-1.90*				
152T-75		0-75	5	2.98	1.40-1.90*				
152T-90		0-90	10	2.98	1.40-1.90*				



Relay Switched Programmable Attenuators, Basic Models . . . dc - 40.0 GHz









Model Number	Frequency Range (GHz)	Attenuation Range (dB)	Step Size (dB)	Insertion Loss, Max. (dB)	Maximum SWR	Connector Type	Average Power (Watts)	Peak Power (Watts)	Page No.
150-11	dc-18.0	0-11	1	2.2	1.50-1.90*	3.5mm	1	100	228
150-15		0-15	1	2.2	1.50-1.90*				
150-31		0-31	1	2.6	1.50-1.90*				
150-62		0-62	2	2.6	1.50-1.90*				
150-70		0-70	10	2.6	1.35-1.70*				
150-75		0-75	5	2.2	1.50-1.90*				
150-110		0-110	10	2.2	1.50-1.90*				
151-11	dc-4.0	0-11	1	0.9	1.50	3.5mm	1	100	228
151-15		0-15	1	2.2	1.50				
151-31		0-31	1	2.6	1.50				
151-62		0-62	2	2.6	1.50				
151-70		0-70	10	2.6	1.35				
151-75		0-75	5	2.2	1.50				
151-110		0-110	10	2.2	1.50				
152-55	dc-26.5	0-55	5	2.98	1.40-1.90*	3.5mm	1	100	228
152-90	dc-26.5	0-90	10	2.98	1.40-1.90*				
152-110	dc-26.5	0-110	10	2.98	1.40-1.90*				
153-70 153-110 (New)	dc-40.0	0-70 0-110	10 10	3.00 4.00	1.30-2.10*	2.92mm	1	100	233



* VARIES WITH FREQUENCY.

Solid-state & Digital Attenuators . . . to 6 GHz



Model Number	Frequency Range (GHz)	Attenuation Range (dB)	Step Size (dB)	Insertion Loss, Maximum (dB)	Maximum SWR	Average Power	Connector Type	Page No.	
4202-63 <i>(New)</i>	0.4-6.0	0-63	1	7.0	2.00	+20 dBm	SMA	235	
4203-31.75 4203-63 <i>(New)</i>	0.2- 3.0	0-31.75 0-63	0.25 1	4.5	1.40	+24 dBm	SMA	237	
4205-31.5 4205-63.5 4205-95.5 <i>(New)</i>	0.4-6.0	0-31.5 0-63.5 0-95.5	0.5 0.5 0.5	3.0 - 4.0* 4.5 - 6.0* 6.5 - 8.0*	1.50-1.70* 1.50-1.80* 1.60-2.00*	+23 dBm	SMA	239	
4226-63 4228-63.75 4228-103	0.8-3.0 0.8-2.5 0.8-3.0	0-63 0-63.75 0-103	1 0.25 1	3.75 4.50 5.50	1.50 1.50 1.50	+28 dBm	SMA	241	
4238-63.75 4238-103	10 MHz-2.5	0-63.75 103	0.25 1	6.75 - 9.25* 6.75 - 9.25*	1.60	+30 dBm	SMA	243	
4246-63 4248-63.75 4248-103	10 MHz-2.5	0-63 0-63.75 103/1	1 0.25	8.00 - 10.00* 10.50 - 13.00* 10.50 - 13.00*	2.00	+36 dBm	SMA	245	
4258-63.75 <i>(New)</i>	2.0 to 6.0	0-63.75	0.25	4.5	2.00	+20 dBm	SMA	247	

* Varies with frequency.

SmartStep® ATTENUATOR UNITS & CONTROLLERS. . . dc to 26.5 GHz, 100 Watts

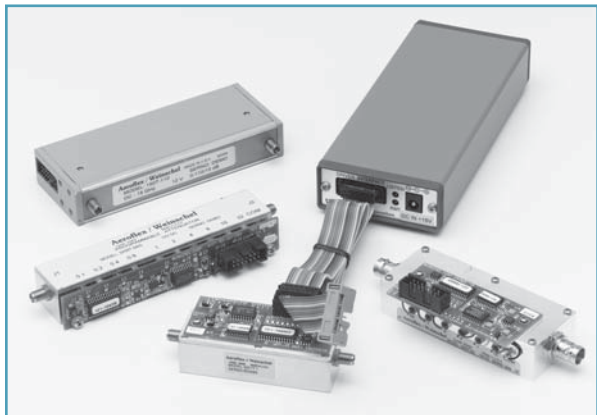

SmartStep® Programmable/Switch Controllers:

(pg 258-260)

The Model 8210A Attenuator / Switch Controller provides a flexible, low cost solution for the control and operation of electromechanical switches and programmable step attenuators using standard communication interfaces. The 8210A represents a new concept in device control applications for bench test and subsystem designs.

- ⚡ Designed to interface with Aeroflex / Weinschel's line of programmable attenuators (3200T & 150T) and other electromechanical devices.
- ⚡ Simplifies your bench test setups and subsystem design.
- ⚡ Available in two standard communication interfaces:
 - Model 8210A-1: GPIB/IEEE-488 (HS-488 ready)
 - Model 8210A-2: RS-232, RS-422, RS-485

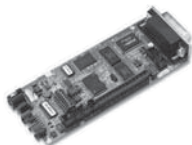

Each model contains similar capabilities and provides switch-selectable parameters to tailor the interface's operation.

SmartStep® 100 W Hot-Switchable High Power Attenuator Unit:

(pages 255-257)

- ⚡ Available in 0-15 dB or 0-31 dB Configurations
- ⚡ DC to 13 GHz Operation
- ⚡ Power Handling up to 100 Watts average
- ⚡ High Accuracy & repeatability
- ⚡ IEEE-488 & Standard Serial Interfaces
- ⚡ Relative vs. Nominal attenuation step function.
- ⚡ Bus Controlled Programmable Attenuator Units



SmartStep® Programmable Attenuator Units for Rack or Bench Use:

(Pages 248-254)

Aeroflex / Weinschel's 8310 & 8311 Series Programmable Attenuator Units represent Aeroflex / Weinschel's newest concept in programmable attenuation for bench test and subsystem applications.



Standard 8310 Series designs house and control various Aeroflex / Weinschel Programmable Attenuator Models (3200T, 150T, and 4200 Series via front panel controls or standard communications interfaces including GPIB (IEEE-488) and RS-232/RS-422/RS485. The standard units combine the features of the Aeroflex / Weinschel 8210A Device Controller with a front panel user interface to form a flexible, easy to use solution.

Most 8310 Series are single channel configurations where RF signal is routed through either the front or rear mounted Ports A & B but can be configured for up to four channels of attenuation, RF switching, or other functions and other features such as:

- ⚡ New 8331 Series (pg 252)
- ⚡ Multi-Channel attenuation paths (up to 4 input/ outputs).
- ⚡ Relative vs. Nominal attenuation step function.
- ⚡ Wide choice of Frequency & Attenuation Ranges.
 - dc to 1, 2, 3, 18 & 26.5 GHz
 - up to 127 dB
 - Solid-State (GaAs FET & PIN)
 - Relay Switched
 - 50 & 75 Ω Configurations
- ⚡ High Accuracy & Repeatability.
- ⚡ Easily mounted into racks or cabinets designed per EIA RS-310 or MIL-STD-189.



Frequently Asked Questions about Programmable Attenuators....

What are the applications of Aeroflex / Weinschel programmable attenuators?

Aeroflex / Weinschel's programmable attenuators are used to control the power of radio frequency and microwave signals. Applications include control of input power to signal measuring systems, control of output power from signal generating systems, adjustment power for BIT error rate testing, controlling losses in a signal path and simulating the signal fading of a microwave communication system....to name just a few.

How do they work?

Aeroflex / Weinschel's programmable attenuators consist of a series of attenuation pads (cells) that are selectively inserted into the signal path via a control signal. An example is a series of cells such as 1, 2, 4, 8 and 16 dB arranged in a binary sequence. Such an attenuator is called a binary attenuator. Combinations of cells are switched "on" to provide attenuation steps from 0 dB to 31 dB. Another example is a unit having cell values of 10, 20 and 40 dB which will provide 10 dB steps between 0 dB and 70 dB.

How are the attenuators switched?

The basic structure of a programmable attenuator is shown below. There are several ways the attenuator pads are switched in and out of the RF path. Aeroflex / Weinschel's 3200 series uses TO-5 can relay switches. These are useful up to 2.0 GHz and higher. Aeroflex / Weinschel's 150 series operate up to 26.5 GHz and utilize reed switches housed within a precision machined cavity.

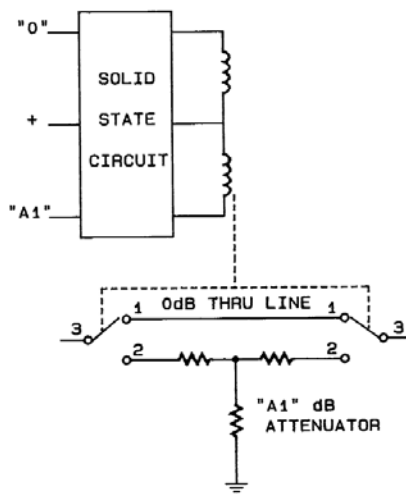

Aeroflex / Weinschel also manufactures programmable attenuators using solid state switching that offers faster switching speeds but their frequency range is more limited than mechanical step attenuators. Whereas mechanically switched attenuators operate from DC to their maximum frequency, solid state attenuators have a lower frequency limit. Solid state attenuators also have lower isolation between control and through path.

How fast do the attenuators switch?

Switching speed of mechanically switched attenuators is typically between 6 and 35 msec. This is the maximum time between the application of the switching command to the cell and the cessation of contact bounce. This time is a function of switch structure and size.

What is a latching and non-latching attenuator?

Non-latching is also called momentary or fail-safe. For the non-latching type, the attenuator is switched to the attenuation "on" position only so long as control power is applied to the switch. As soon as power is removed the switch reverts to its passive state or fail-safe state...usually the zero dB state. In latching attenuators each cell stays in the last setting even if power is removed. Latching attenuators have two control lines. One control line causes the attenuator to switch to the "attenuation on" setting while the other control line causes the attenuator to switch to the zero dB setting. There is normally a permanent magnet that holds the switch stable in either position.



Each version has its advantages and disadvantages. The non-latching switch requires constant power to the solenoid when in the "on" position. On the other hand the latching version requires greater switch current to overcome its permanent magnet.

How are the attenuators controlled?

The Model 3200 and 3400 Series non-latching attenuators require only one 12 volt control line per cell. The direction of control current is not important.

The Model 150 Series is a latching version using one positive 5 volt or 24 volt common return line and two grounding control lines.

In order for switching to be guaranteed the voltage between common and control must be held within specified limits. Power supply regulation must be kept within range even while heavy switching current is being drawn. Any cable voltage drops must be added to the minimum control voltage to obtain the required power supply voltage at the attenuator.

Aeroflex / Weinschel's programmable attenuators, such as the Model 3200T, 3400T and 150T Series feature on-board TTL drivers. TTL driver boards are also available for most models.

Programmable Attenuators



What is the switch life of these programmable attenuators?

Specified life for mechanical switches is normally in the range of 1 to 10 million switching. This specification is per switch, independent of the other switches in the attenuator. For the Model 150 series attenuators the specification is 5 million cycles, i.e. one cycle is the switch moving in both directions. These specifications are based on the mechanical life of the switch, however, other factors have an impact on attenuator life. High power operation can have an adverse effect on the switch contact surfaces. This can reduce the overall life of the switch by causing the attenuator performance to go outside it's specification.

What is monotonicity?

A programmable step attenuator is considered monotonic if it's attenuation always increases when it is commanded to increase. This applies on a per frequency basis. For instance the 20 dB setting at 1 GHz will always be less than the 21 dB setting at 1 GHz. This does not necessarily mean that the 20 dB setting at 1 GHz will always be less than the 21 dB setting 18 GHz. Monotonicity is influenced by the SWR of the individual attenuator cells as the cells are combined to form an attenuation value. It is also influenced by the summation of individual cell attenuation tolerances as the cells are combined.

What is the difference between insertion loss and incremental attenuation?

Programmable attenuators have insertion loss and also incremental attenuation. Insertion loss is the loss through the attenuator when all cells are switched to zero dB. It is the residual loss of the device itself. Insertion loss usually increases with frequency reaching several dB at the higher frequencies and generally has very flat frequency response. Incremental attenuation is the attenuation values of the attenuators cells relative to the insertion loss. Since insertion loss is always present, the performance of a programmable attenuator is always given as incremental attenuation relative to insertion loss. Insertion loss is considered part of the fixed performance of the system path in which the programmable attenuator is located.

What is the advantages of Attenuators with built-in driver circuitry?

These attenuators feature an internal microcontroller-based driver that provides a TTL-level digital interface for control of the attenuator relays (Figure 1). This card simplifies operation and interfacing requirements, while at the same time providing for greatly enhanced flexibility over past designs. User-selectable modes of operation include both parallel and serial bus. The parallel mode provides a simple, one-bit per relay on/off control with internal pullups for use primarily in single attenuator applications. This mode allows the attenuator to be controlled via a variety of methods, such as a TTL-level digital output port, or mechanical toggle switches. The serial mode provides a two-wire serial bus structure and protocol for connecting a number of devices to

a single host control interface, suitable for use in larger system and sub-system applications. The built-in driver™ contains non-volatile configuration memory that is used to hold a wide variety of attenuator and driver-dependent parameters, including serial number, attenuator cell dB values, relay configurations, and switching requirements, which are all accessible via the digital interface. This frees the system designer from such low-level details, allowing faster integration. In either operational mode, the microcontroller enters an idle condition during periods of inactivity, turning off all on-board clocks, reducing EMI concerns, and lowering power consumption. On-board regulation for the digital circuitry allows the programmable attenuator to operate from a single input supply voltage.

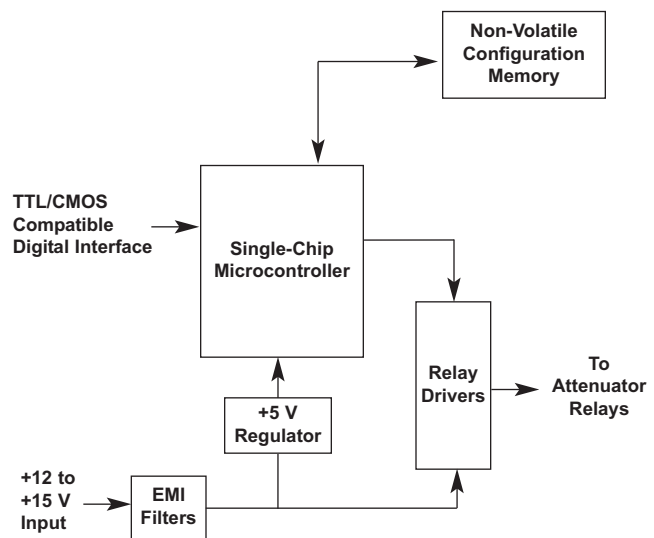

Figure 1. Digital Driver Circuitry

How can I control the Attenuators with built-in drivers?

The communications interface (Model 8210A) provides a flexible, low cost solution for the operation of programmable step attenuators and other electromechanical devices under computer control. Designed to interface to Aeroflex / Weinschel's line of programmable attenuators built-in intelligent drivers, the Model 8210A represents a new concept in device control applications for bench test and subsystem designs. The 8210A communications interface provides a high-level interface from various industry standard communications interfaces, including IEEE-488 and RS232 /RS422/RS485, to the programmable attenuators serial Driver Interface Bus.

Intermodulation Distortion in Programmable Attenuators...

Weinschel has been a major supplier of programmable attenuators to the RF industry for over 30 years. Historically the most demanding specifications for these components have been low insertion loss and SWR, combined with a reasonable life expectancy of several million switching cycles. This was usually adequate for RF instruments like spectrum analyzers and signal generators, wherein the attenuator bandwidth rather than the switching speed was of prime concern. To achieve wide bandwidths the programmable attenuators were mostly of electromechanical design and the linearity of these passive components was not only assumed but never questioned by any customer. Intermodulation distortion discussions and problems were usually limited to components such as amplifiers, mixers and filters.

In recent years, however, wireless communication systems employing complex digital modulation schemes, increased channel capacity, high transmit power and extremely low receiver sensitivity have put into question the linearity of passive components. Even very low level multi-tone intermodulation products generated by attenuators can seriously degrade the efficiency of a system/instrument if these products fall within the user pass-band. For two closely spaced tones at frequencies f_1 and f_2 , the third order IM products at $2f_1 - f_2$ and $2f_2 - f_1$, are the most harmful distortion products. They are harmful because they are located close to f_1 and f_2 and virtually impossible to filter out. In today's base stations the multicarrier power amplifier (MCPA) is replacing banks of single-channel amplifiers and their corresponding power combining network. MCPAs have the capability of carrying a number of modulation schemes simultaneously and can also employ schemes such as dynamic-channel-allocation (DCA) to use the allocated frequency spectrum more efficiently. The in-band intermodulation distortion (IMD) performance of these amplifiers is extremely critical and needs to be measured using low distortion programmable multi-tone generators whose IMD performance must be quite superior. This is discussed in the two case studies cited here.

Electromechanical programmable attenuators obviously provide a far superior IMD performance than their corresponding solid state counterparts employing semiconductor switching elements.

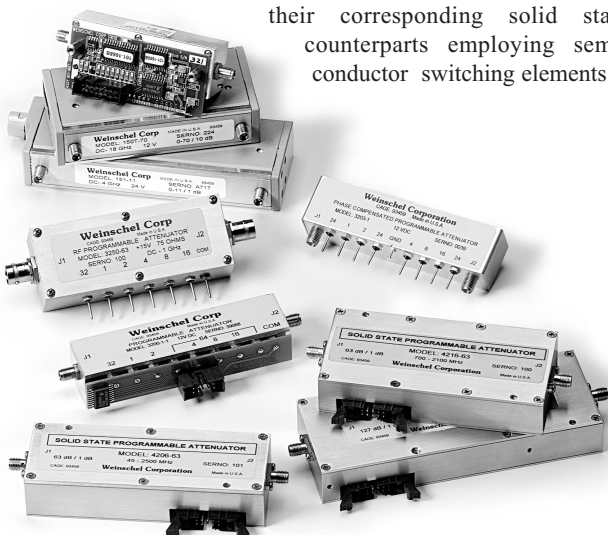

However, their slow switch speed, in the order of milliseconds, and short switch life in the order of 5-10 million cycles make them unattractive in some applications like cell phone testing and other ATE systems. Solid State programmable attenuators do overcome these two problems and are therefore included here for IMD performance comparison. It is not the intent of this brief article to go into the theory of intermodulation distortion. The goal here is to provide some good basic IMD test data for a variety of commercial programmable attenuators and let the end user select the most appropriate type for his application.

Measurement System and Parameters...

All test data presented here was generated using a commercially available Passive IM Analyzer, Summitek Model SI-800A which provides a fully integrated system for characterizing distortion produced by cables, attenuators and other passive devices. Although the system is capable of measuring both, through and reflected IM3, IM5, IM7 and IM9, the focus here is only on through IM for the most troublesome third order product, IM3. To carry out a meaningful comparison between different attenuators all measurements were carried out using two equal amplitude input tones at 869 MHz (f_1) and 891 MHz (f_2), the IM3 frequency being 847 MHz ($2f_1 - f_2$). Input carrier power was stepped in increments of 1 dB from -7dBm to +27dBm. All external adapters and cables were carefully selected to maintain the system's residual IM level of around -120 dBm. Although the system permitted receiver measurements between -70 to -120 dBm we restricted all measurements between -85 to -110 dBm by using a calibrated low IM coupler and attenuators at the output port of the DUT. One must be aware that the accuracy of such small signal measurements can easily be off by 2 to 3 dB so restricting the measurement dynamic range helps reduce the receiver non-linearity error. Measurements were done over several days to ensure stability and repeatability.

Distortion Comparison for Basic Types of Programmable Attenuators...

The programmable attenuators discussed here are the switched type with a discrete number of 'cells'. Switching between the zero and attenuate state on each cell is achieved by a DPDT switch configuration. The cell values are usually in a binary sequence. For example a 6 cell/6 bit unit could have 1, 2, 4, 8, 16 and 32 dB sections providing a 63 dB dynamic range in 1dB increments. Four basic families of programmable attenuators are compared, each family being identified by the switch element used to achieve the transfer from zero to attenuate state.

For the purposes of distortion comparison it was deemed necessary to select units with similar electrical length and/or programmability. Both the electromechanical units, TO5 relay and edge-line type, had an electrical length of about 20 cms. The two solid state units had 6 cell programmability yielding 63 dB in 1 dB step size. All IM3 vs Pin measurements were done with the attenuators programmed to be in their characteristic zero insertion loss state. The zero state was selected because it generated the highest IM3 levels. The graph below shows the obvious compromise in IMD performance for the two solid state

Programmable Attenuators



types. It is worth noting that the IM3 vs Pin slope is not exactly 3:1 as would be the case in a perfect third order device. The theoretical two tone third order intercept point, IP3, commonly used as a figure of merit for comparing linearity is shown in the following table at two different input power levels. The input IP3 is derived from the following relation:

$$\text{Input IP3} = \frac{3(\text{Pin}-\alpha)-\text{IM3}}{2} + \alpha$$

where α = zero insertion loss of each unit @ 847 MHz, the IM3 frequency. IM3 and Pin are selected from Table 1.

TABLE 1. SPECIFICATION COMPARISONS:

Parameter	Attenuator Type			
	PIN	FET	Relay	Edge-Line
IP3 @ 10 dBm	42.0 dBm	48.0 dBm	72 dBm	98 dBm*
IP3 @ 24dBm	39.0 dBm	53.5 dBm	75 dBm	98 dBm
I. Loss	2.0 dB	5.0 dB	1.5 dB	0 dB
Switching Time	2 μ sec	2 μ sec	5 msec	20 msec
Switch Life	∞	∞	10 million	5 million
Frequency (GHz)	0.8-2.3	0.01-2.5	dc-3	dc-26.5

* NOTE: Although the actual IM3 was not measurable the curve for the edge-line unit is linear and predictable unlike the two curves for the solid state attenuators. If we were to extrapolate this curve we would get the same IP3 figure of +98dBm as expected.

IM3 Performance of Electromechanical & Solid State Programmable Attenuators

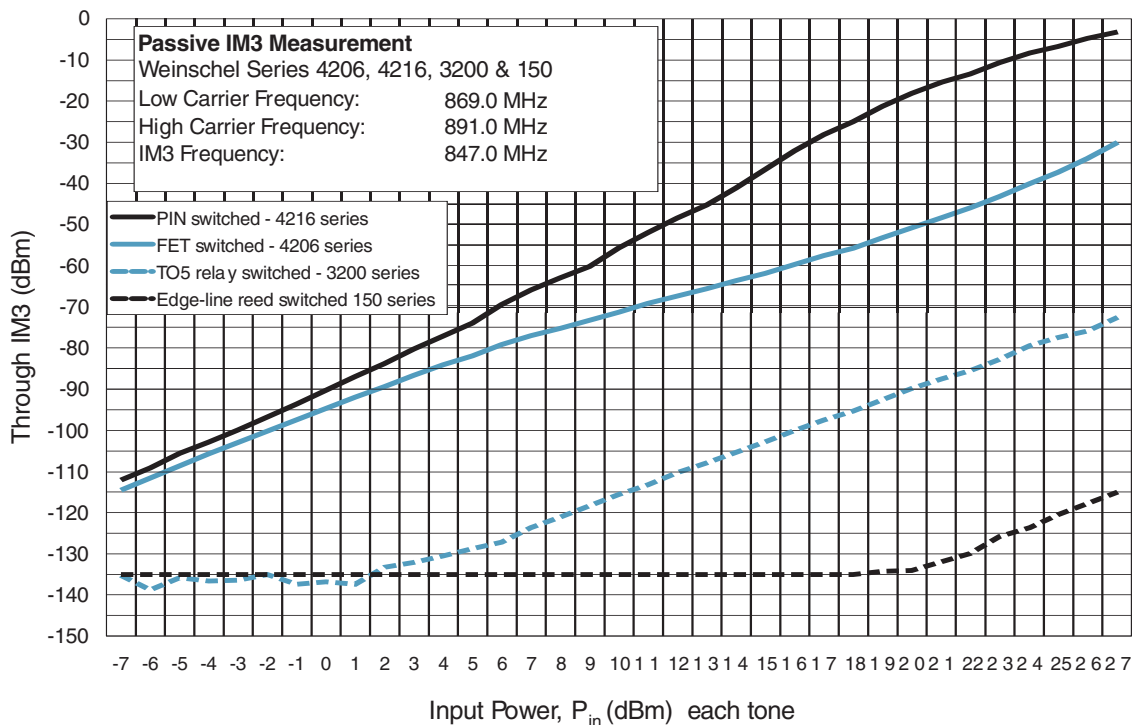

Case Study 1

Company A offers its IMD series Phase Aligned 8 tone generators to test intermodulation distortion in multi-carrier power amplifiers. The output level of these generators is accurately controlled using a Weinschel TO5 relay based programmable attenuator offering over 60 dB dynamic range. Eight +13 dBm carriers are input to the attenuator. In MCPAs with feedforward correction, in-band IMD levels could be as low as -75 dBc so Company A wanted at least -85 dBc at the output of their generator. The first problem was that Weinschel could not simulate the exact test conditions. This was readily resolved by establishing a good co-relation between our two tone IM3 measurement and Company A's 8 tone test. Having employed the best plating techniques and using good low IM connector design the attenuator was still short of the required IMD spec. The final improvement was achieved by extensive testing on relays from three different manufacturers. Figure 2 shows IM3 plots of the two best performers. Manufacturer B consistently provided a 4 to 5 dB improvement at the two tone level at Pin of +22 dBm and higher. This corresponded to an acceptable output distortion level for the Company A generator.

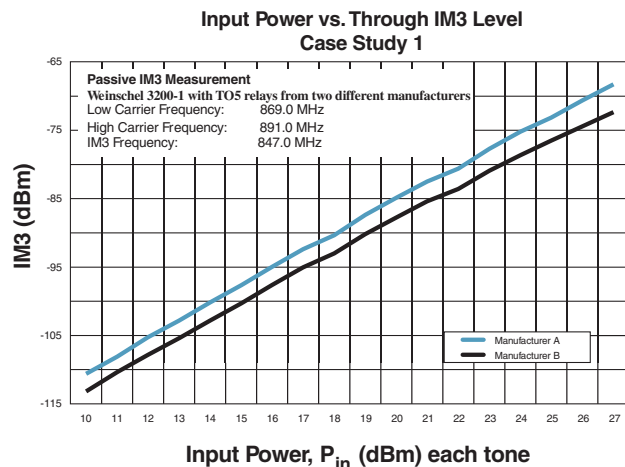

Case Study 2

Company B manufactures ultra low distortion multi-tone signal generators. Their units offer up to 160 channels from 5 MHz through 1 GHz. Each carrier can be leveled as high as +10 dBm. One of their most stringent requirements is a cross modulation test. The Company B generator specification is -100 dB below the sideband of a 100% amplitude modulated carrier, which is -110 dBc. The actual components used in the critical path had to measure -120 dBc or better. Their generator needed an ultra linear attenuator to provide a programmed output level in 0.5 dB increments. Relay based units were tested and found to be unacceptable. The high performance edge-line attenuators were expected to solve the problem but at first they too fell short, but mainly in their zero attenuation state, which generates maximum distortion. Prior to supplying these units to Company B no customer had asked for a distortion specification on these supposedly passive attenuators. Environmental performance had warranted the use of nickel underplate on the edge lines. This was disclosed

to the customer and suspected to be the prime cause of high IMD levels. Since the unit was going to be mounted in a benign environment, elimination of the nickel underplate was not thought to be a problem. Figure 3 demonstrates the tremendous reduction in IM3 levels upon elimination of the nickel underplate—a significant 40 dB! A further 10-15 dB improvement was achieved by redesigning the connectors to reduce their passive IMD. The IM improvement in these connectors would have served no purpose prior to the elimination of nickel. This is because the main source of distortion lay behind the connector back plane, along the edge transmission line, which had a far greater electrical length than the two connectors.

Input Power vs. Through IM3 Level Case Study 2

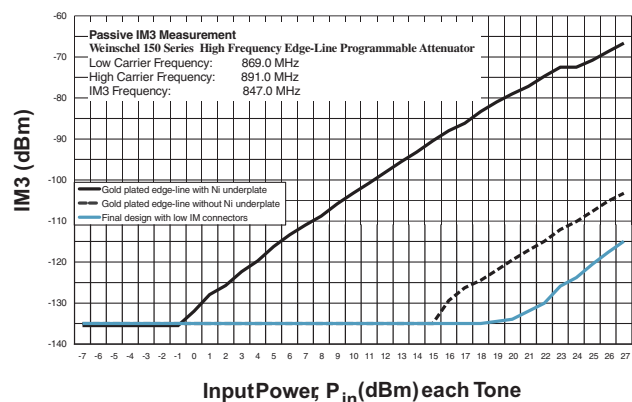

Conclusion

Abundant intermodulation test data for four families of programmable attenuators has been presented in an easy format, together with their other key performance features. This should enable instrument and system designers to select the most suitable type for their application.

The two case studies have also demonstrated that an OEM component supplier cannot possibly simulate the different distortion test scenarios of every customer. Such tests would be extremely varied, complex and cost prohibitive. The IM analyzer used at Weinschel was indeed a narrow band instrument and one might be concerned about the unit's performance at other frequencies. This is a legitimate concern for the solid state types, in which the distortion mechanism is a strong function of the operating frequency. For the broadband electromechanical types this is not a major issue. However, with a meaningful two tone intermodulation measurement it is quite possible to get an excellent correlation with the customer's test conditions and thereby come up with a corresponding specification under the two tone test. It is helpful though, to be able to replicate the total power level that the unit would be subjected to in the field.

Author: Jimmy Dholoo, VP Engineering @ Aeroflex / Weinschel
© April 1999, Wireless Design & Development

Programmable Attenuators



Model 3200 Series Programmable Attenuators with optional TTL Interface

dc to 3.0 GHz
1 Watt

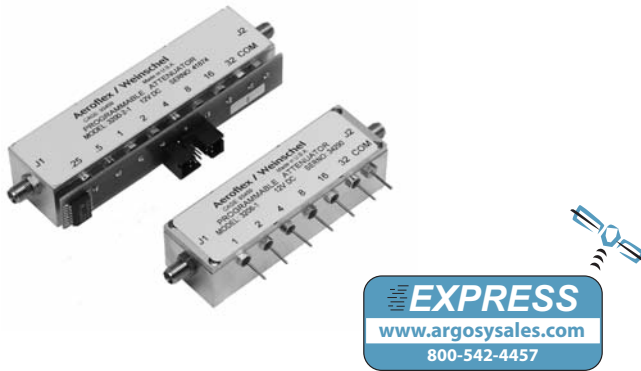

Features

- /// **Widest Selection of Attenuation Ranges & Step Sizes**
- /// **Available Express Models:** 3200-1E, 3200-1E-2, 3200-2E, 3201-1E, 3206-1E
Other models may be available for Express delivery.
- /// **High Quality Construction & Connectors**
- /// **Special Configurations Available Upon Request**
 - Custom Cell/Step Size Configurations
 - Higher Frequencies

Description

The 3200 Series Programmable Step Attenuators are designed for use in automatic test equipment and OEM systems operating in the dc to 3 GHz frequency range. This series is available in many standard attenuation ranges and cell configurations. Custom designed configurations are available upon request. Each cell contains a double-pole, double-throw relay that provides a zero path or attenuated path for the RF signal.

Microstrip circuitry and special compensation techniques produce flat attenuation versus frequency characteristics. To minimize RF leakage, the 3200 Series Attenuators are provided with gold-plated contact areas and feedthrough filters at each control terminal.

Specifications

NOMINAL IMPEDANCE: 50 Ω
FREQUENCY RANGE: dc to 3.0 GHz

CELL CONFIGURATIONS:

Model Number	NO. Cells	Attenuation Range/Steps (dB)	Cell Increments (dB)
3200-1E	8	127/1	1, 2, 4, 8, 16, 32, 64*
3200-2E	8	63.75/0.25	0.25, 0.5, 1, 2, 4, 8, 16, 32
3201-1E	5	31/1	1, 2, 4, 8, 16
3205-1E	4	70/10	10, 20, 20, 20
3205-2E	4	55/5	5, 10, 20, 20
3205-3E	4	1.5/0.1	0.1, 0.2, 0.4, 0.8
3206-1E	6	63/1	1, 2, 4, 8, 16, 32
3209-1E	10	64.5/0.1	0.1, 0.2, 0.4, 0.8, 1, 2, 4, 8, 16, 32

* 64 dB cell comprised of two 32 dB cells

MAXIMUM SWR:

Frequency Range (GHz)	3200-XE, 3201-1E 3205-XE, 3206-1E	3209-1E
dc - 2	1.25	1.35
2 - 3	1.40	1.45

INCREMENTAL ATTENUATION ACCURACY:

Frequency Range (GHz)	Accuracy
dc - 0.5	± 0.2 dB or 0.5%
0.5 - 1	± 0.2 dB or 1.0%
1 - 3	± 0.3 dB or 2.0%

MONOTONICITY: 10 MHz to 3.0 GHz
(minimum 1dB change)

POWER COEFFICIENT: <0.002 dB/dB/watt

INCREMENTAL TEMPERATURE COEFFICIENT:

32 dB cells: 0.0005 dB/dB/°C

All other cells: 0.0002 dB/dB/°C

POWER RATING: 1 watt average to 25°C ambient temperature, derated linearly to 0.25 watt @ 71°C. 50 watts peak (5 μsec pulse width; 1% duty cycle)

Specifications - Con't

MAXIMUM INSERTION LOSS (dB):					
Frequency Range (GHz)	3200-1E 3200-2E	3201-1E	3205-1E, 3205-2E 3205-3E	3206-1E	3209-1E
dc - 0.5	2.50	1.70	1.50	2.20	3.00
0.5 - 1.0	3.20	2.20	1.75	2.40	3.60
1.0 - 1.5	3.50	2.50	2.00	2.80	4.20
1.5 - 2.0	4.00	2.80	2.25	3.10	4.60
2.0 - 3.0	4.70	3.25	2.60	3.70	5.50

RATED SWITCH LIFE: 5 million cycles operations per cell @ 0 dBm

SWITCHING TIME: 6 msec. maximum at nominal rated voltage

RELEASE TIME: 3 msec maximum

CYCLING RATE: 5 Hz maximum per relay

OPERATING VOLTAGE: +12 Vdc (+4 / -2 V)

OPERATING CURRENT: 30 mA typical per cell @ +12V

TEMPERATURE RANGE (Operating): -55°C to +71°C

TEST DATA: Test data is available at additional cost.

CONNECTORS: SMA female connectors per MIL-STD-348 interface dimensions - mate nondestructively with MIL-C-39012 connectors.

CONTROL TERMINALS: 0.040 inch. (1 mm) diameter solderable leads. May be used with PC board sockets/receptacles.

CONSTRUCTION:

Housing: Aluminum
Connectors: Stainless steel body and beryllium copper contacts.

Control terminals: Brass/Copper, Silver plated

WEIGHT (Typical):

3200-1E & 3200-2E:	117 g (4.1 oz)
3201-1E:	89 g (3.1 oz)
3205-1E, 3205-2E, 3205-3E:	77 g (2.7 oz)
3206-1E:	99 g (3.5 oz)
3209-1E:	159 g (5.6 oz)

MODEL NUMBER DESCRIPTION:

320X-YE For a basic 3 GHz model*
320X-YE-1 Add -1 for a TTL driver board with a 10 pin ribbon cable connector
320X-YE-2 Add -2 for a TTL driver board with a 15 pin D connector

* Use the Cell Configuration table to determine X and Y for available attenuation ranges.

CONTROL CONFIGURATION:

Standard Unit: One terminal is connected to case ground and the remaining terminals are provided for activation of individual cells. Attenuation is fail-safe to "0" setting in the absence of a control voltage. Application of a voltage (+) to a particular cell causes it to switch to the attenuate position.

Units with TTL Option: Units with this option are supplied with a very low profile connectorized TTL interface board mounted directly to the control terminals. This TTL interface option is available with either a 10 pin ribbon cable connector or a 15 pin "D" connector (**limited models**), refer to list below. Each type is supplied with a mating connector. Refer to Physical Dimensions for mating connector pin/wiring details. Two wires are specified for supply voltage and ground. The remaining wires will accept TTL control signals to activate or de-activate a particular attenuation cell. A TTL high will energize a cell to the high attenuation state, whereas a TTL low will maintain a cell in its zero attenuation state.

To order 3200 Series Attenuators with this option add -1 to basic model number for ribbon cable connector and -2 for the "D" connector. Example: Model 3201-1E with a TTL interface board would be 3201-1E-1. Mating connector is provided. To order a TTL Driver board separately for an existing 3200 Series Attenuator, use the following:

Basic Model No.	TTL BD Kit Part No.	
	10 Pin Ribbon	15 Pin "D" CONN
3200-1E, 3200-2E	101-1781	101R-1798-000**
3201-1E	101-1780	101R-1798-001**
3205-1E, 3205-2E	101-1780	101R-1798-001**
3205-3E		
3206-1E	101-1780	101R-1798-001**
3209-1E	101-1804-000*	N/A

* 14 pin ribbon connector.

** 3 FT TTL Interface Cable Part No. 101-1805 supplied with unit.

Note: Control is non-latching and requires a continuous control signal for the period of time in which attenuation is required.

INTERFACE CONNECTOR: Option -1 (Models 3200, 3201, 3205 and 3206): 10 pin .025 square post header on .1 center, mates with Amp connector 746285-1 or equivalent. Option -1 (3209): 14 pin .025 square post header on .1 center, mates with Amp connector 746285-2 or equivalent. Option -2: 15 pin D Socket Connector, mates with Cannon connector DA-15S or equivalent.

Programmable Attenuators



TTL DRIVER SPECIFICATIONS:

INPUT VOLTAGE: V_{IN} High = +2.0V minimum
+5.0V typical
 V_{CC} maximum
 V_{IN} Low = 0 minimum
0.8 maximum

INPUT CURRENT: I_{IN} ($V_{IN}=2.4$ V) = 55 μ A
 I_{IN} ($V_{IN}=3.85$ V) = 280 μ A

SUPPLY CURRENT (Digital Section): $I_{CC}=25.0$ mA maximum

SUPPLY CURRENT (per cell continuos): 30 mA per cell

SUPPLY VOLTAGE: $V_{CC}=+12.0$ to +15V

TEMPERATURE RANGE (Operating): -40°C to +70°C

MODELS WITH BUILT-IN DRIVERS: All 3200s are available with an intelligent interface/driver cards. These are designed to interface with our 8210A Series Controllers which greatly simplifies computer control applications. Refer to 3200T Series data sheet for more information.

PHYSICAL DIMENSIONS:

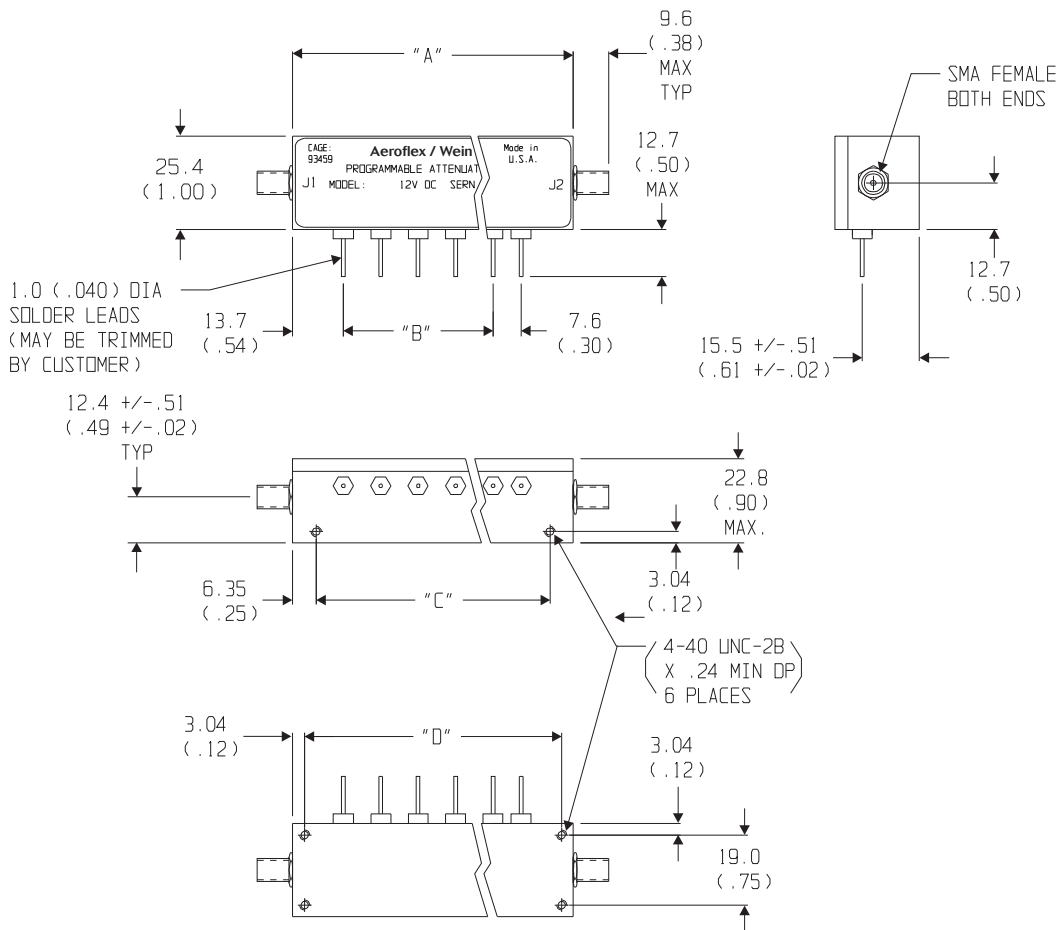

Model No.	No. Cells	A	B	C	D
3200-XE	8	101.6 (4.0)	7 EQ SPCS @ 10.16 (.40) = 71.1 (2.80)	88.9 (3.50)	95.2 (3.75)
3201-XE	5/4	76.2 (3.00)	4 EQ SPCS @ 10.16 (.40) = 40.64 (1.60)	63.5 (2.50)	69.8 (2.75)
3205-XE	4	58.9 (2.32)	3 EQ SPCS @ 10.16 (.40) = 30.5 (1.20)	46.2 (1.82)	52.6 (2.07)
3206-XE	6	81.3±0.5 (3.20±0.02)	5 EQ SPCS @ 10.16 (.40) = 50.8 (2.00)	68.6 (2.70)	75.18 (2.96)

NOTE: All dimensions are given in mm (inches) and are maximum, unless otherwise specified.

PHYSICAL DIMENSIONS:

TTL OPTION -1 (3200, 3201, 3206):

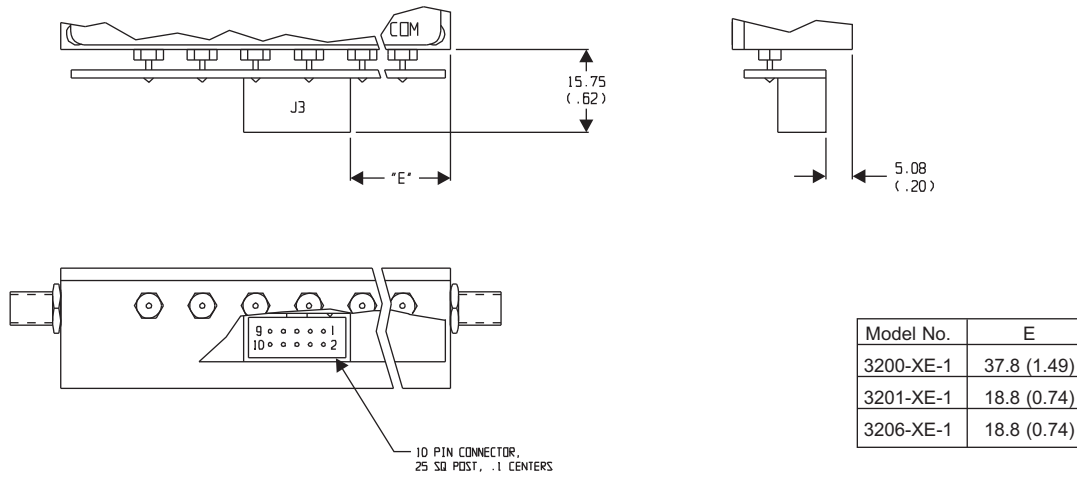

TTL OPTION -1 (3205):

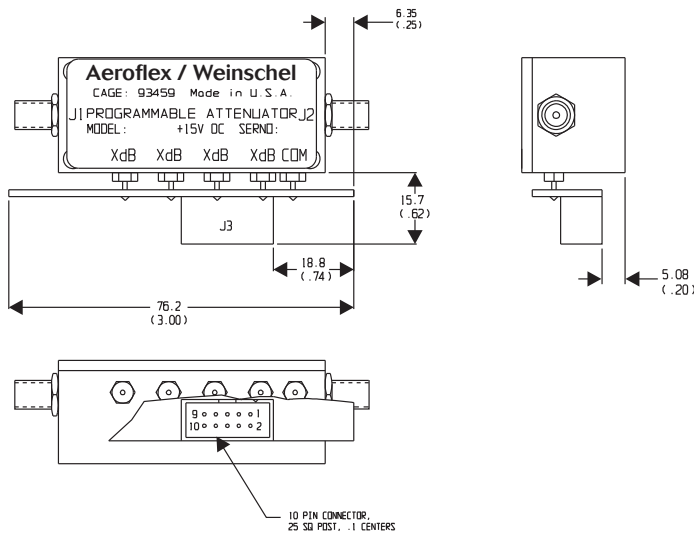

Control Connector J3 Pin Locations:

TTL Conn PIN No. (J3)	3200-1E-1 dB (Cell)	3200-2E-1 dB (Cell)	3201-1E-1 dB (Cell)	3205-1E-1 dB (Cell)	3205-2E-1 dB (Cell)	3205-3E-1 dB (Cell)	3206-1E-1 dB (Cell)
1	32	0.25	NC	NC	NC	NC	NC
2	1	0.5	NC	NC	NC	NC	NC
3	2	1	1	NC	NC	NC	1
4	32*	2	2	10	5	0.1	2
5	4	4	4	20	10	0.2	4
6	8	8	8	20	20	0.4	8
7	16	16	16	20	20	0.8	16
8	32*	32	NC	NC	NC	NC	32
9	COM	COM	COM	COM	COM	COM	COM
10	+Vcc	+Vcc	+Vcc	+ Vcc	+ Vcc	+Vcc	+ Vcc

*64 dB cell comprised of two 32 dB cells
 **60 dB cell comprised of two 30 dB cells
 NC = Not Connected

NOTE: All dimensions are given in mm (inches) and are maximum, unless otherwise specified.

Programmable Attenuators



PHYSICAL DIMENSIONS:

TTL Driver Option -2 (3200, 3201, 3205):

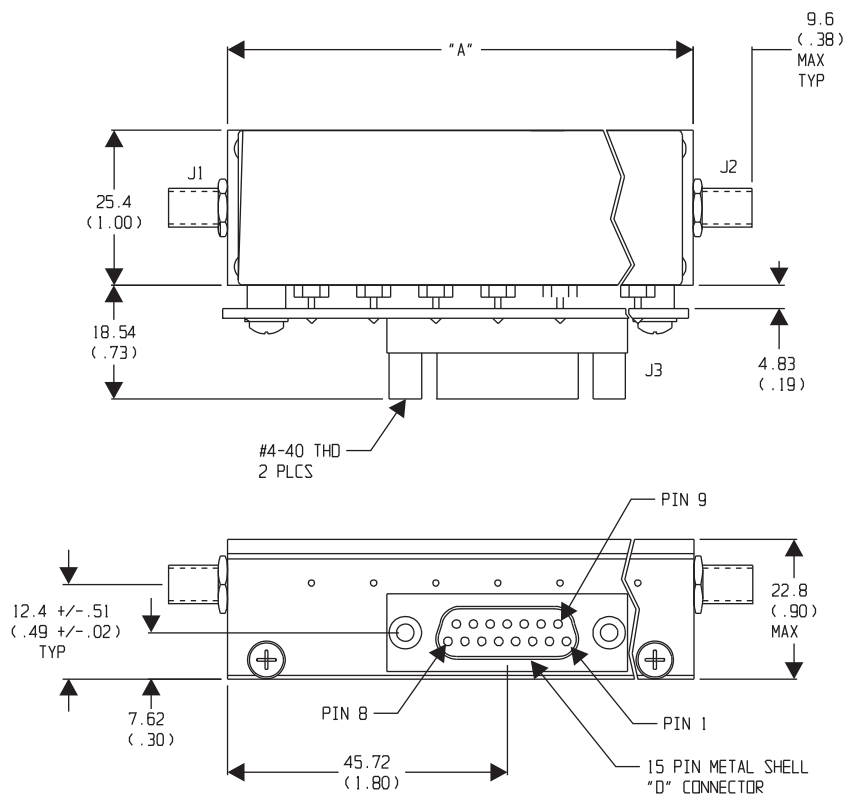

Model No.	A
3200-XE-2	101.6 (4.00)
3201-XE-2	76.2 (3.00)
3205-XE-2	76.2 (3.00)

Control Connector J3 Pin Locations:

"D" Conn PIN No. (J3)	3200-1E-2 dB (Cell)	3200-2E-2 dB (Cell)	3201-1E-2 dB (Cell)	3205-1E-2 dB (Cell)	3205-2E-2 dB (Cell)	3205-3E-2 dB (Cell)	Cable (P/N 101-1805) Color Code
1	32	32	NC	NC	NC	NC	BRN
2	16	16	NC	NC	NC	NC	YEL
3	8	8	NC	NC	NC	NC	GRN
4	4	4	16	20	20	0.8	LT BLU
5	32	0.25	1	NC	NC	NC	VIO
6	1	0.5	2	10	5	0.1	GRY
7	2	1	4	20	10	0.2	WHT
8	32*	2	8	20	20	0.4	WHT/BLK
9	NC	NC	NC	NC	NC	NC	RED
10	GND	GND	GND	GND	GND	GND	BLK
11	NC	NC	NC	NC	NC	NC	---
12	NC	NC	NC	NC	NC	NC	---
13	NC	NC	NC	NC	NC	NC	---
14	NC	NC	NC	NC	NC	NC	---
15	+Vcc	+Vcc	+Vcc	+Vcc	+Vcc	+Vcc	ORN

*64 dB cell comprised of two 32 dB cells
 **60 dB cell comprised of two 30 dB cells
 NC = Not Connected

NOTE: All dimensions are given in mm (inches) and are maximum, unless otherwise specified.

PHYSICAL DIMENSIONS:

Model 3209-1E:

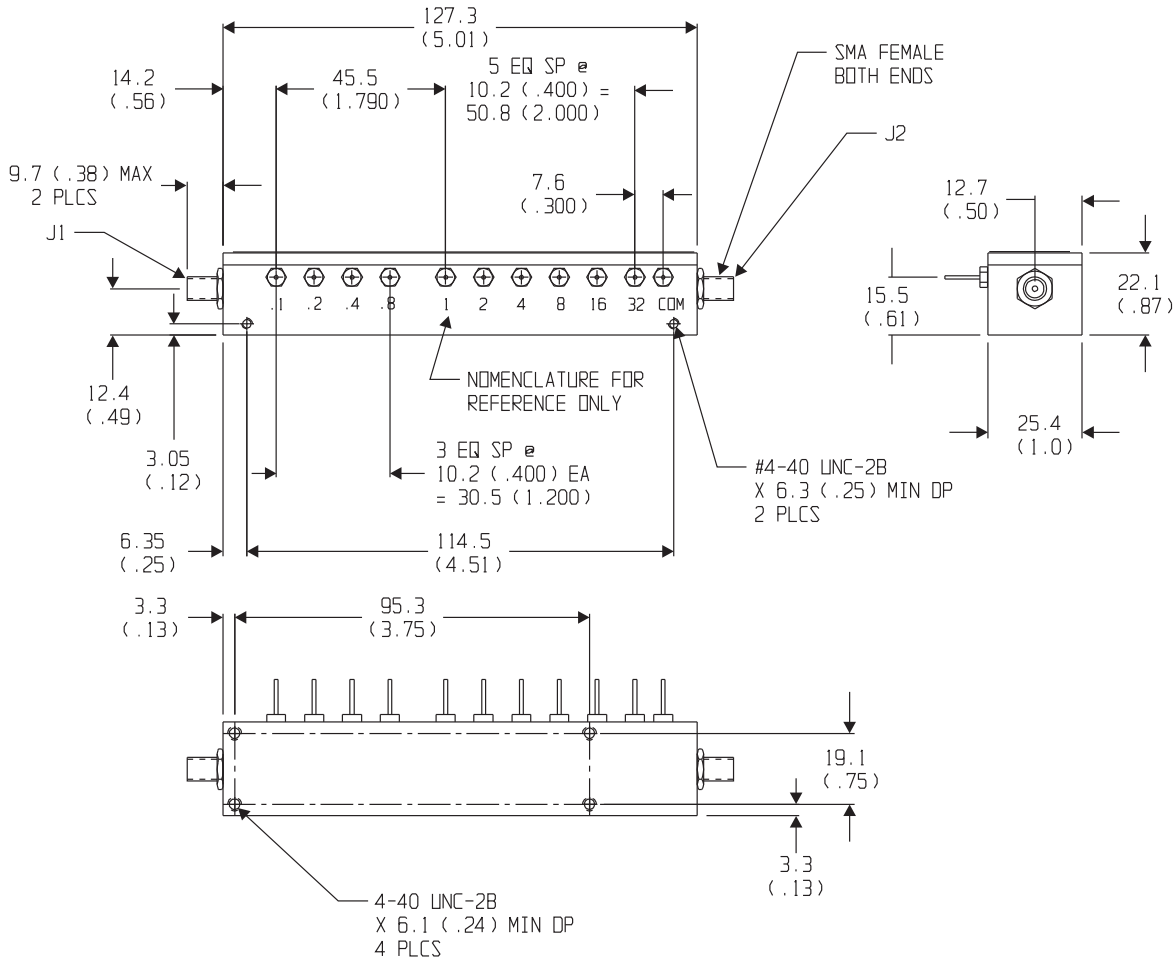

Model 3209-1E-1 (TTL Option -1):

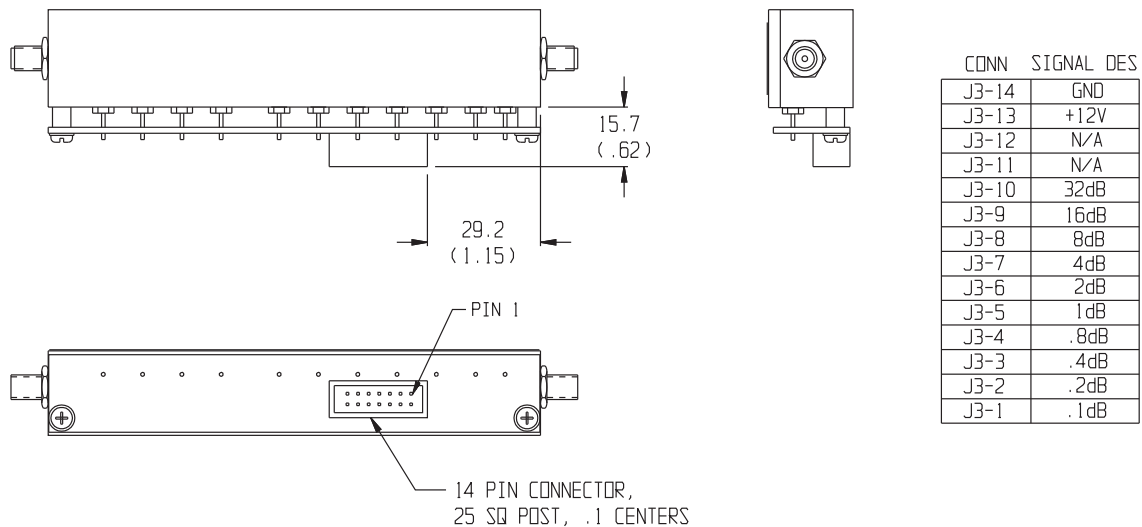

NOTE: All dimensions are given in mm (inches) and are maximum, unless otherwise specified.

Programmable Attenuators



Model 3200T

SmartStep® Programmable Attenuators with built-in Microprocessor-Based Driver

dc to 3.0 GHz
1 Watt

For Use with Weinschel 8210A Controller

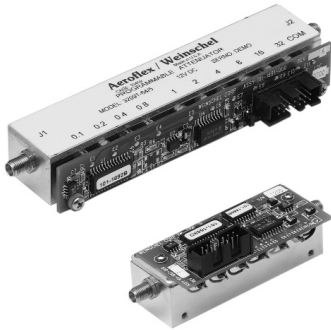

Features

- /// **Widest Selection of Attenuation Ranges & Steps Sizes**
- /// **Built-In TTL\CMOS Interface Driver Circuitry**
- /// **High Quality Construction and Connectors**
- /// **Special Configurations Available Upon Request**
 - Custom Cell/Step Size Configurations
 - Higher Frequencies (See 3400 Series)

Description

This line of intelligent programmable step attenuators with a built-in digital interface are designed to simplify the control and integration of these devices into subsystem and bench applications. This series of Programmable Step Attenuators is designed for use in automatic test equipment and OEM systems operating in the dc to 3 GHz frequency range. These models are available in many standard attenuation ranges and cell configurations. Each cell contains a double-pole, double-throw relay that provides a minimum loss or attenuated path for the RF signal.

Microstrip circuitry and special compensation techniques produce flat attenuation versus frequency characteristics. To minimize RF leakage, the 3200T Series Attenuators are provided with gold-plated contact areas and feedthrough filters at each control terminal.

Specifications

NOMINAL IMPEDANCE: 50 Ω
FREQUENCY RANGE: dc to 3.0 GHz

CELL CONFIGURATIONS:

Model Number	NO. Cells	Attenuation Range/Steps (dB)	Cell Increments (dB)
3200T-1E	8	127/1	1, 2, 4, 8, 16, 32, 64*
3200T-2E	8	63.75/0.25	0.25, 0.5, 1, 2, 4, 8, 16, 32
3201T-1E	5	31/1	1, 2, 4, 8, 16
3201T-2E	5	120/10	10, 20, 30, 60**
3205T-1E	4	70/10	10, 20, 20, 20
3205T-2E	4	55/5	5, 10, 20, 20
3205T-3E	4	1.5/0.1	0.1, 0.2, 0.4, 0.8
3206T-1E	6	63/1	1, 2, 4, 8, 16, 32
3209T-1E	10	64.5/0.1	0.1, 0.2, 0.4, 0.8, 1, 2, 4, 8, 16, 32

*64 dB cell comprised of two 32 dB cells

MAXIMUM SWR:

Frequency Range (GHz)	3200T-XE, 3201T-1E 3205T-XE, 3206T-1E	3209T-1E
dc - 2	1.25	1.35
2 - 3	1.40	1.45

INCREMENTAL ATTENUATION ACCURACY:

Frequency Range (GHz)	Accuracy
dc - 0.5	± 0.2 dB or 0.5%
0.5 - 1	± 0.2 dB or 1.0%
1 - 3	± 0.3 dB or 2.0%

MONOTONICITY: 10 MHz to 3.0 GHz
(minimum 1 dB change)

POWER COEFFICIENT: <0.002 dB/dB/watt

INCREMENTAL TEMPERATURE COEFFICIENT:

30 & 32 dB cells: 0.0005 dB/dB/°C

All other cells: 0.0002 dB/dB/°C

Specifications - Con't

MAXIMUM INSERTION LOSS (dB):					
Frequency Range (GHz)	3200T-1E 3200T-2E	3201T-1E	3205T-1E, 3205T-2E 3205T-3E	3206T-1E	3209T-1E
dc - 0.5	2.50	1.70	1.50	2.20	3.00
0.5 - 1.0	3.20	2.20	1.75	2.40	3.60
1.0 - 1.5	3.50	2.50	2.00	2.80	4.20
1.5 - 2.0	4.00	2.80	2.25	3.10	4.60
2.0 - 3.0	4.70	3.25	2.60	3.70	5.50

POWER RATING: 1 watt average to 25°C ambient temperature, derated linearly to 0.25 watt @ 71°C. 50 watts peak (5 µsec pulse width; 1% duty cycle)

RATED SWITCH LIFE: 5 million cycles operations per cell @ 0 dBm

CYCLING RATE: 5 Hz maximum per relay

DRIVER INTERFACE:

Input Supply Voltage: +12.0 to +15 V
 Control Signals: TTL/CMOS compatible
 Interface Modes: parallel / serial
 DC Characteristics (at 25 °C):

Parameter	Specification
V _{IL} Low-level input V:	-0.5 V min, 0.8 V max
V _{IH} High-level input V:	2.0 V min, 5.25 V max
I _{PU} Pullup current	50 µA min, 400 µA max
V _{IN} Supply Voltage:	+12.0 to +15.0 V
I _{IN} Supply current:	25 mA
(digital section)	
I _{CELL} Supply current:	30 mA (per cell) continuous

TEMPERATURE RANGE (Operating): -20°C to +70°C

TEST DATA: Test data is available at additional cost.

CONNECTORS: SMA female connectors per MIL-STD-348 interface dimensions - mate nondestructively with MIL-C-39012 connectors.

INTERFACE CONNECTOR: 14 pin .025 square post header on .1 center. Mates with Amp connector 746285-2 or equivalent.

CONSTRUCTION:

Housing: Aluminum
 Connectors: Stainless steel body and beryllium copper contacts.

WEIGHT:	3200T-XE	165 g (8.4 oz)
	3201T-XE	132 g (7.3 oz)
	3205T-XE	132 g (7.3 oz)
	3206T-XE	132 g (7.3 oz)
	3209T-XE	218 g (9.7 oz)

ACCESSORIES

Programmable Attenuator/Switch Controller: The Model 8210A Programmable Attenuator/Switch Controller provides a flexible, low cost solution for the operation of programmable step attenuators and other electromechanical devices under computer control. Designed to interface to Aeroflex / Weinschel's intelligent programmable attenuators, the 8210A represents a new concept in device control applications for bench test and subsystem designs. The 8210A provides a high-level interface from various industry standard communications interfaces, including IEEE-488 and RS232/RS422/RS485, to the programmable attenuator's serial Driver Interface Bus.

CONTROL CONFIGURATION

These programmable attenuators feature an internal microcontroller-based driver that provides a TTL-level digital interface for control of the attenuator relays. This card simplifies operation and interfacing requirements, while at the same time providing for greatly enhanced flexibility over past designs. User-selectable modes of operation include both parallel and serial bus. The parallel mode provides a simple, one-bit per relay on/off control with internal pullups for use primarily in single attenuator applications. This mode allows the attenuator to be controlled via a variety of methods, such as a TTL-level digital output port, or mechanical toggle switches. The device bus provides a two-wire serial bus structure and protocol for connecting a number of devices to a single host control interface, suitable for use in larger system and sub-system applications. The digital interface contains non-volatile configuration memory that is used to hold a wide variety of attenuator and driver-dependent parameters, including serial number, attenuator cell dB values, relay configurations, and switching requirements, which are all accessible via the digital interface.

In either operational mode, the microcontroller enters an idle condition during periods of inactivity, turning off all on-board clocks, reducing EMI concerns, and lowering power consumption. On-board regulation for the digital circuitry allows the attenuator to operate from a single input supply voltage.

Programmable Attenuators



PHYSICAL DIMENSIONS:

Model 3200T, 3201T, 3205T, & 3206T:

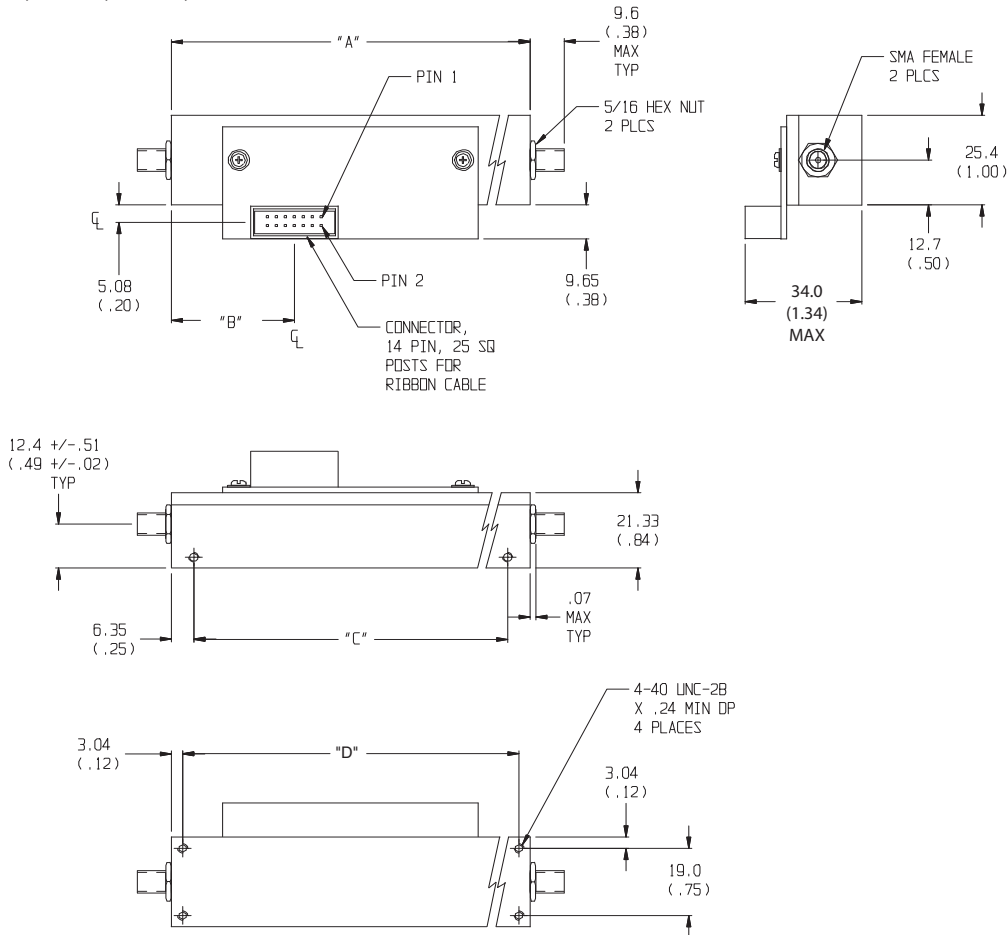

Model No.	No. Cells	A	B	C	D
3200T-XE	8	101.6 (4.0)	31.8 (1.25)	88.9 (3.50)	95.2 (3.75)
3201T-XE	5/4	76.2 (3.00)	19.1 (0.75)	63.5 (2.50)	69.8 (2.75)
3205T-XE	4	72.4 (2.85)	19.1 (0.75)	46.2 (1.82)	52.6 (2.07)
3206T-XE	6	81.3±0.5 (3.20±0.02)	21.46 (0.85)	68.6 (2.70)	75.18 (2.96)

Model 3209T:

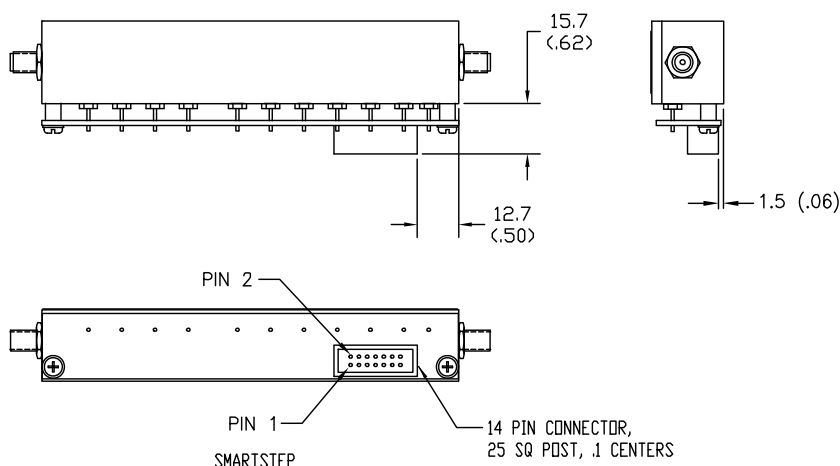

CONN	SIGNAL DES
J3-14	N/A
J3-13	N/A
J3-12	N/A
J3-11	N/A
J3-10	N/A
J3-9	N/A
J3-8	N/A
J3-7	N/A
J3-6	N/A
J3-5	N/A
J3-4	GND
J3-3	GND
J3-2	+V
J3-1	+V

SMARTSTEP SYSTEM ONLY
NO PARALLEL MODE OPERATION

NOTE: All dimensions are given in mm (inches) and are maximum, unless otherwise specified.

Models 3404, 3406 & 3408 Programmable Attenuators with optional TTL Interface

dc to 6.0 GHz
1 Watt



Features

- /// Higher Frequency range to 6 GHz.
- /// Wide Selection of Attenuation Ranges & Step Sizes
 - 0 to 15 dB in 1 dB steps
 - 0 to 55 dB in 1 dB steps
 - 0 to 55.75 in 0.25 dB steps
 - 0 to 103 dB in 1 dB steps
 - 0 to 70 dB in 10 dB steps
- /// High Quality Construction & Connectors
- /// Special Configurations Available Upon Request

Description

The 3400 Series Programmable Step Attenuators are designed for use in automatic test equipment and OEM systems operating in the dc to 6 GHz frequency range. This series is available in many standard attenuation ranges and cell configurations. Custom designed configurations are available upon request. Each cell contains a double-pole, double-throw relay that provides a zero path or attenuated path for the RF signal.

Microstrip circuitry and special compensation techniques produce flat attenuation versus frequency characteristics. The microstrip construction, using thin-film circuit elements, ensures product uniformity. To minimize RF leakage, the 3400 Series Attenuators are provided with gold-plated contact areas and feedthrough filters at each control terminal.

Specifications

NOMINAL IMPEDANCE: 50 Ω
FREQUENCY RANGE: dc to 6.0 GHz

MAXIMUM SWR:	
Frequency Range (GHz)	SWR
dc - 3	1.30
3 - 6	1.45

CELL CONFIGURATIONS:

Model Number	NO. Cells	Attenuation Range/Steps (dB)	Cell Increments (dB)
3404-15	4	15/1	1, 2, 4, 8
3404-55	4	55/5	5, 10, 20, 20
3404-70	4	70/10	10, 20, 20, 20
3406-55	6	55/1	1, 2, 4, 8, 16, 24
3408-55.75	8	55.75/0.25	0.25, 0.5, 1, 2, 4, 8, 16, 24
3408-103	8	103/1	1, 2, 4, 8, 16, 24, 48*

*48 dB cell comprised of two 24 dB cells

INCREMENTAL ATTENUATION ACCURACY:

Frequency Range (GHz)	Accuracy
dc - 3	±0.3 dB or 2% whichever is greater
3 - 6	±0.4 dB or 3% whichever is greater

MAXIMUM INSERTION LOSS (dB):

Frequency Range (GHz)	3404-15 3404-55 3404-70	3406-55	3408-55.75 3408-103
dc - 3	1.80	2.60	3.40
3 - 6	2.60	3.80	5.00

MONOTONICITY: dc to 6.0 GHz (minimum 1 dB change)

POWER RATING: 1 watt average to 25°C ambient temperature, derated linearly to 0.25 watt @ 70°C. 50 watts peak (5 μsec pulse width; 1% duty cycle)

POWER COEFFICIENT: <0.005 dB/dB/watt

RATED SWITCH LIFE: 5 million cycles operations per cell @ 0 dBm

SWITCHING TIME: 6 msec. maximum at nominal rated voltage

RELEASE TIME: 5 msec maximum

CYCLING RATE: 5 Hz maximum per relay

OPERATING VOLTAGE: +12 Vdc (+13 V maximum; +9 V minimum)

OPERATING CURRENT: 17 mA typical per cell @ +12 V

TEMPERATURE RANGE (Operating): -30°C to +70°C

TEST DATA: Test data is available at additional cost.

Programmable Attenuators



SPECIFICATIONS - Con't

CONNECTORS: SMA female connectors per MIL-STD-348 interface dimensions - mate nondestructively with MIL-C-39012 connectors. Leads may be used with PC board sockets/ receptacles.

CONTROL TERMINALS: 0.040 inch. (1 mm) diameter solderable leads. May be used with PC board sockets/ receptacles.

CONSTRUCTION:

Housing: Aluminum
Connectors: Stainless steel body and beryllium copper contacts.

Control terminals: Brass/Copper, Silver plated

WEIGHT (Typical): 3404-X: 99 g (3.5 oz)
3406-X: 99 g (3.5 oz)
3408-X: 135 g (4.8 oz)

CONTROL CONFIGURATION:

Standard Unit: One terminal is connected to case ground and the remaining terminals are provided for activation of individual cells. Attenuation is fail-safe to "0" setting in the absence of a control voltage. Application of a voltage (+) to a particular cell causes it to switch to the attenuate position.

Units with TTL Option: Units with this option are supplied with a very low profile connectorized TTL interface board mounted directly to the control terminals. This TTL interface option is available with a 10 pin ribbon cable connector and is supplied with a mating connector. Refer to Physical Dimensions for mating connector pin/wiring details. Two wires are specified for supply voltage and ground. The remaining wires will accept TTL control signals to activate or de-activate a particular attenuation cell. A TTL high will energize a cell to the high attenuation state, whereas a TTL low will maintain a cell in its zero attenuation state.

To order 3400 Series Attenuators with this option add -1 to basic model number for ribbon cable connector. Example: Model 3406-63 with a TTL interface would be 3406-63-1.

Note: Control is non-latching and requires a continuous control signal for the period of time in which attenuation is required.

TTL DRIVER SPECIFICATIONS:

INTERFACE CONNECTOR: Option -1: 10 pin .025 square post header on .1 center, mates with Amp connector 746285-1 or equivalent

INPUT VOLTAGE: V_{IN} High = +2.0V minimum
+5.0V typical
 V_{CC} maximum
 V_{IN} Low = 0 minimum
0.8 maximum

INPUT CURRENT: I_{IN} ($V_{IN}=2.4$ V) = 55 μ A
 I_{IN} ($V_{IN}=3.85$ V) = 280 μ A

SUPPLY CURRENT: $I_{CC}=25$ mA maximum per cell

SUPPLY VOLTAGE: $V_{CC}=+12.0$ to +15 V

MODELS WITH BUILT-IN DRIVERS: Most 3400s are available with an intelligent interface/driver cards. These are designed to interface with our 8210A Series Controllers which greatly simplifies computer control applications. Refer to Model 3406T and 3408T data sheet for more information.

PHYSICAL DIMENSIONS:

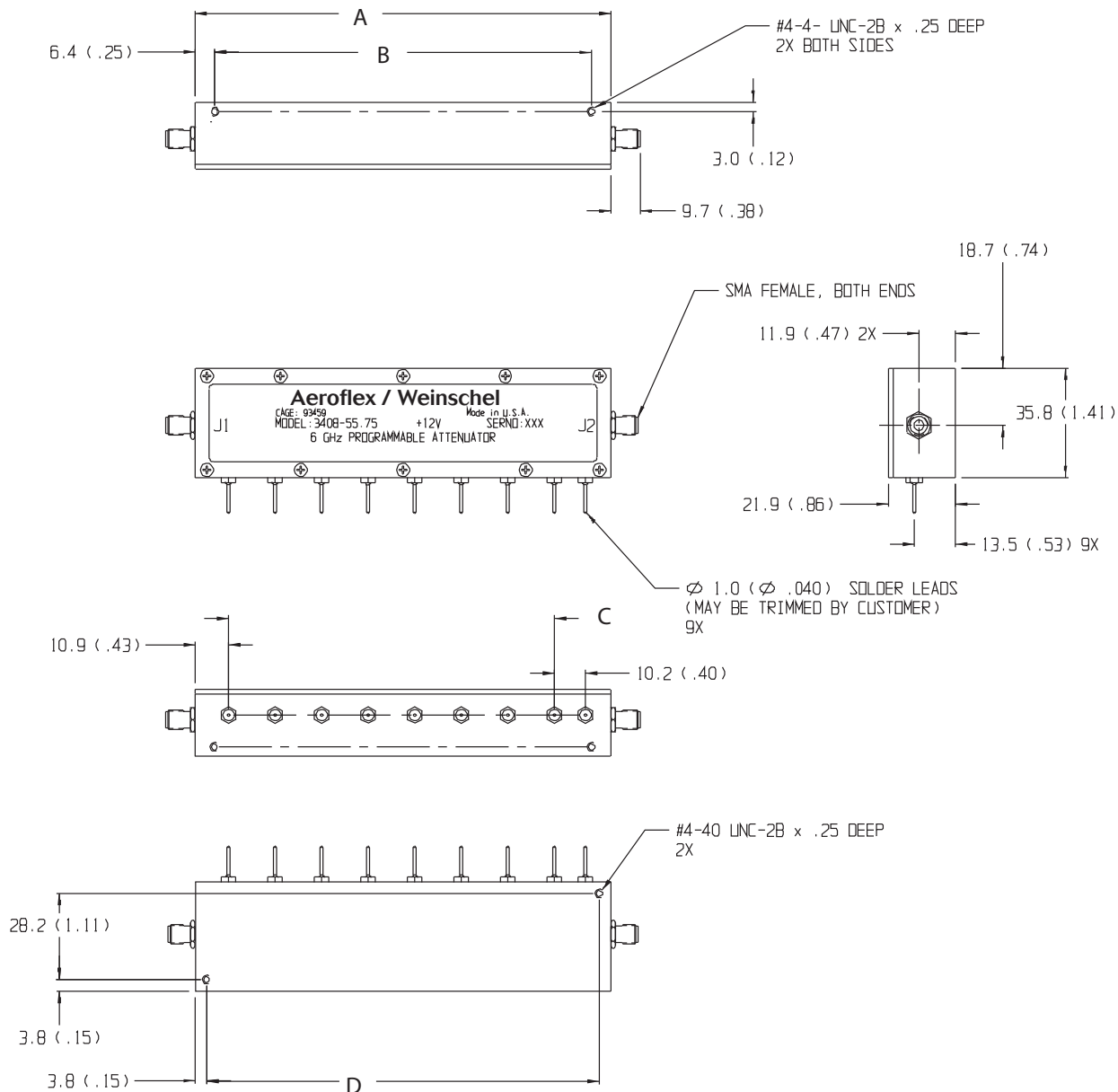

Model No.	No. Cells	A	B	C	D
3408-X	8	136.1 (5.36)	123.4 (4.86)	7 EQ SPCS @ 15.20 (.60) = 106.7 (4.20)	128.5 (5.06)
3406-X	6	105.7 (3.66)	93.0 (3.66)	5 EQ SPCS @ 15.20 (.60) = 76.0 (3.00)	98.0 (3.86)
3404-X	4	75.18 (2.96)	62.48 (2.46)	3 EQ SPCS @ 15.20 (.60) = 45.72 (1.80)	67.56 (2.66)

NOTE: All dimensions are given in mm (inches) and are nominal, unless otherwise specified.

Programmable Attenuators



PHYSICAL DIMENSIONS:

TTL OPTION -1 (3406 & 3408)

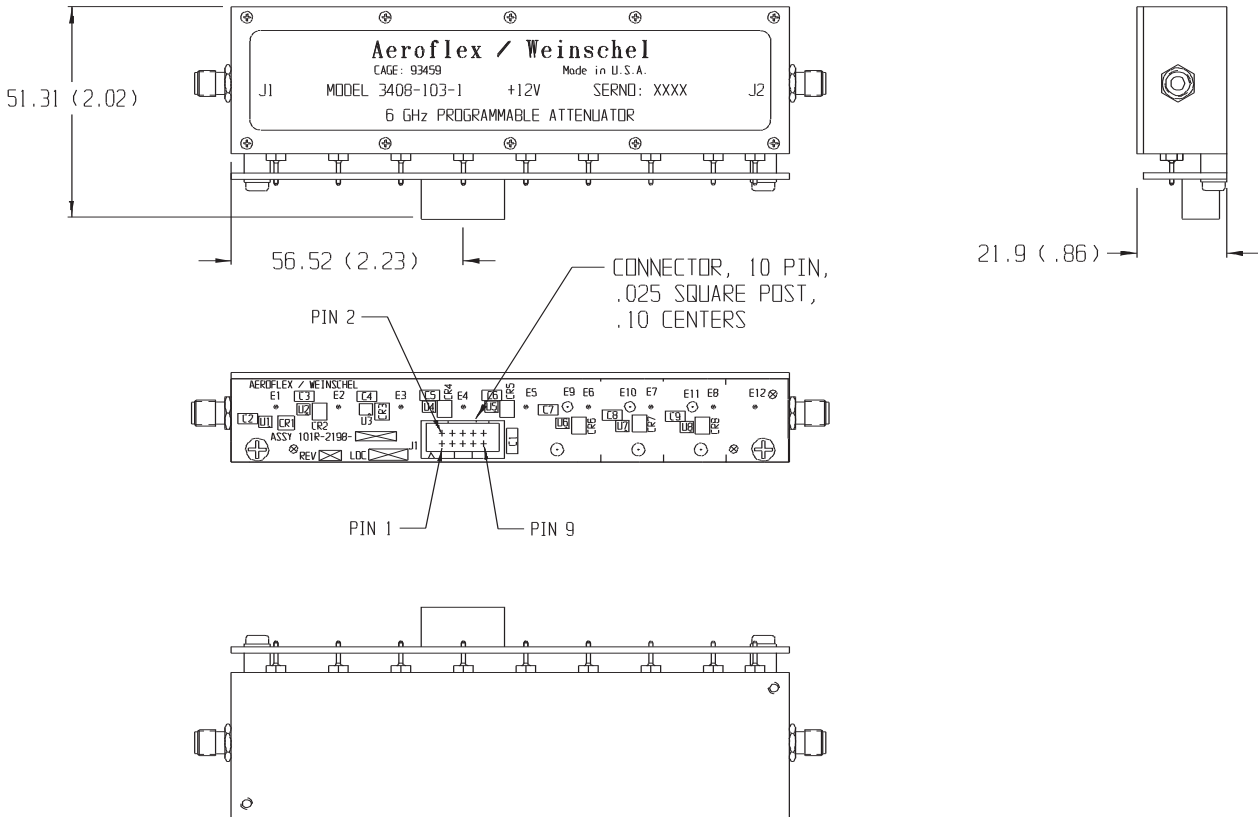

Control Connector J3 Pin Locations:

TTL Conn PIN No. (J3)	3408-103-1 dB (Cell)	3408-55.75-1 dB (Cell)	3406-55-1 dB (Cell)	3404-15-1 dB (Cell)	3404-55-1 dB (Cell)	3404-70-1 dB (Cell)
1	24*	0.25	1	1	5	10
2	24	0.5	2	2	10	20
3	1	1	4	4	20	20
4	2	2	8	8	20	20
5	4	4	16	NC	NC	NC
6	8	8	24	NC	NC	NC
7	16	16	NC	NC	NC	NC
8	24*	24	NC	NC	NC	NC
9	+Vcc	+Vcc	+Vcc	+Vcc	+Vcc	+Vcc
10	COM	COM	COM	COM	COM	COM

* 48 dB cell comprised of two 24 dB cells
 NC = Not Connected

NOTE: All dimensions are given in mm (inches) and are nominal, unless otherwise specified.

Models 3404T, 3406T & 3408T SmartStep® Programmable Attenuators with built-in Microprocessor-Based Driver For Use with Weinschel 8210A Controller

dc to 6.0 GHz
1 Watt

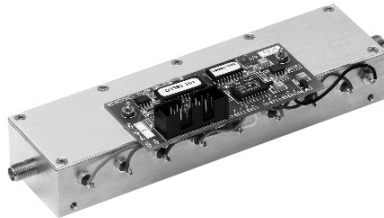

Features

- /// Higher Frequency range to 6 GHz.
- /// Wide Selection of Attenuation Ranges & Step Sizes
 - 0 to 15 dB in 1 dB steps
 - 0 to 55 dB in 1 dB steps
 - 0 to 55.75 in 0.25 dB steps
 - 0 to 103 dB in 1 dB steps
 - 0 to 70 dB in 10 dB steps
- /// High Quality Construction & Connectors
- /// Built-In TTL\CMOS Interface Driver Circuitry
- /// Special Configurations Available Upon Request

Description

This line of intelligent programmable step attenuators with a built-in digital interface are designed to simplify the control and integration of these devices into subsystem and bench applications. This series of Programmable Step Attenuators is designed for use in automatic test equipment and OEM systems operating in the dc to 6 GHz frequency range. These models are available in many standard attenuation ranges and cell configurations. Each cell contains a double-pole, double-throw relay that provides a minimum loss or attenuated path for the RF signal.

Microstrip circuitry and special compensation techniques produce flat attenuation versus frequency characteristics. The microstrip construction, using thick-film circuit elements, ensures product uniformity. To minimize RF leakage, the 3400T Series Attenuators are provided with gold-plated contact areas and feedthrough filters at each control terminal.

Specifications

NOMINAL IMPEDANCE: 50 Ω
FREQUENCY RANGE: dc to 6.0 GHz

MAXIMUM SWR:	
Frequency Range (GHz)	SWR
dc - 3	1.30
3 - 6	1.45

CELL CONFIGURATIONS:

Model Number	NO. Cells	Attenuation Range/Steps (dB)	Cell Increments (dB)
3404T-15	4	15/1	1, 2, 4, 8
3404T-55	4	55/5	5, 10, 20, 20
3404T-70	4	70/10	10, 20, 20, 20
3406T-55	6	55/1	1, 2, 4, 8, 16, 24
3408T-55.75	8	55.75/0.25	0.25, 0.5, 1, 2, 4, 8, 16, 24
3408T-103	8	103/1	1, 2, 4, 8, 16, 24, 48*

*48 dB cell comprised of two 24 dB cells

INCREMENTAL ATTENUATION ACCURACY:

Frequency Range (GHz)	Accuracy
dc - 3	±0.3 dB or 2% whichever is greater
3 - 6	±0.4 dB or 3% whichever is greater

MAXIMUM INSERTION LOSS (dB):

Frequency Range (GHz)	3404T-15 3404T-55 3404T-70	3406T-55	3408T-55.75 3408T-103
dc - 3	1.80	2.60	3.40
3 - 6	2.60	3.80	5.00

MONOTONICITY: dc to 6.0 GHz (minimum 1 dB change)

POWER RATING: 1 watt average to 25°C ambient temperature, derated linearly to 0.25 watt @ 70°C. 50 watts peak (5 μsec pulse width; 1% duty cycle)

POWER COEFFICIENT: <0.005 dB/dB/watt

RATED SWITCH LIFE: 5 million cycles operations per cell @ 0 dBm

SWITCHING TIME: 6 msec. maximum at nominal rated voltage

RELEASE TIME: 5 msec maximum

SWITCHING SPEED: 5 Hz maximum per relay

OPERATING VOLTAGE: +12V (+13V maximum; +9V minimum)

OPERATING CURRENT: 17 mA typical per cell @ +12V

TEMPERATURE RANGE (Operating): -30°C to +70°C

Programmable Attenuators



Specifications - Con't

DRIVER INTERFACE:

Parameter	Specification
V _{IL}	Low-level input V: -0.5V min, 0.8V max
V _{IH}	High-level input V: 2.0V min, 5.25V max
I _{PU}	Pullup current: 50 μA min, 400 μA max
V _{IN}	Supply Voltage: +12.0 to +15.0V
I _{IN}	Supply current: 25 mA
I _{CELL}	Supply current: 16.6 mA @ 12V (digital section)

TEST DATA: Test data is available at additional cost.

CONNECTORS: SMA female connectors per MIL-STD-348 interface dimensions - mate nondestructively with MIL-C-39012 connectors.

INTERFACE CONNECTOR: 14 pin .025 square post header on .1 center. Mates with Amp connector 746285-2 or equivalent.

CONSTRUCTION:

Housing: Aluminum
 Connectors: Stainless steel body and beryllium copper contacts.
 Control terminals: Brass/Copper, Silver plated

WEIGHT (Typical): 3406T-X: 99 g (3.5 oz)
 3408T-X: 135 g (4.8 oz)

PHYSICAL DIMENSIONS:

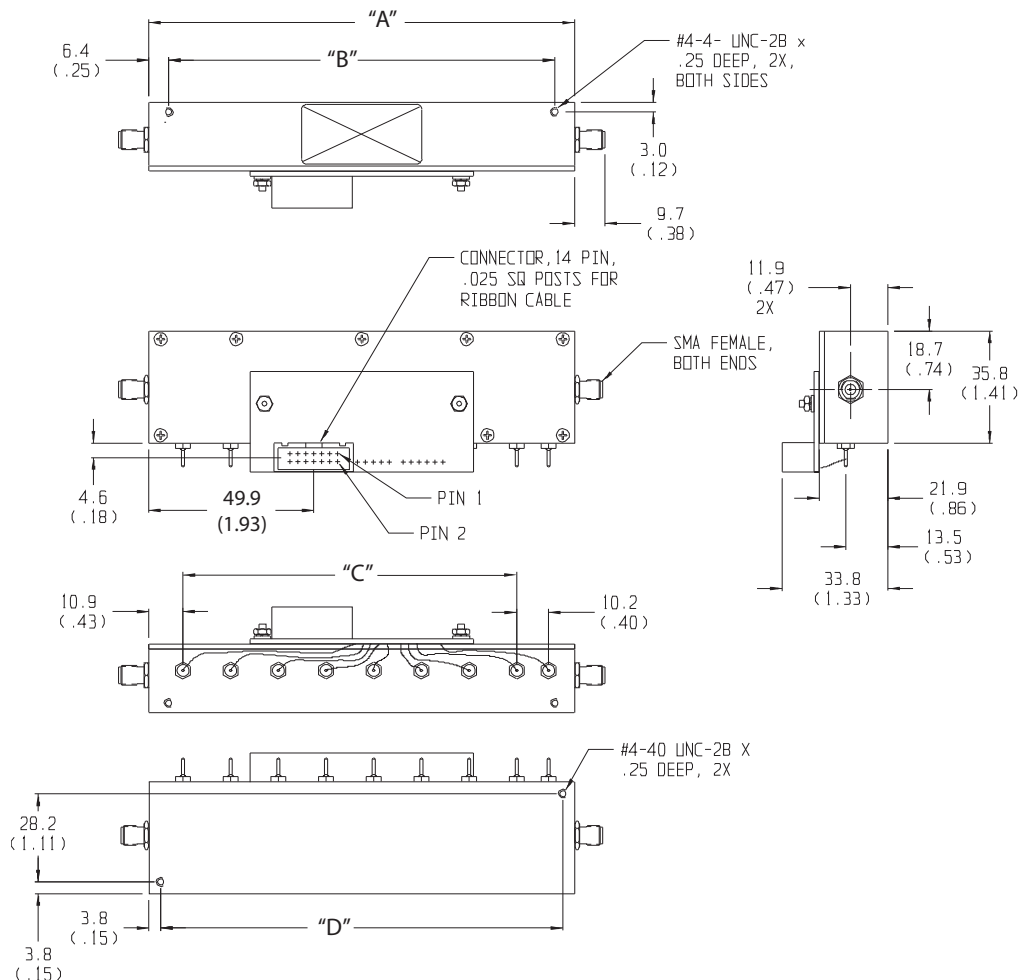

Model No.	No. Cells	A	B	C	D
3408-X	8	136.1 (5.36)	123.4 (4.86)	7 EQ SPCS @ 15.20 (.60) = 106.7 (4.20)	128.5 (5.06)
3406-X	6	105.7 (3.66)	93.0 (3.66)	5 EQ SPCS @ 15.20 (.60) = 76.0 (3.00)	98.0 (3.86)
3404-X	4	75.18 (2.96)	62.48 (2.46)	3 EQ SPCS @ 15.20 (.60) = 45.72 (1.80)	67.56 (2.66)

NOTE: All dimensions are given in mm (inches) and are nominal, unless otherwise specified.

Model 150T

Model 151T

Model 152T

**SmartStep® Relay Switched Programmable Attenuators,
with built-in Microprocessor-Based Driver**

dc to 18.0 GHz

dc to 4.0 GHz

dc to 26.5 GHz

For Use with Weinschel 8210A Controller



Description

Aeroflex / Weinschel's line of intelligent programmable step attenuators with a built-in TTL interface (Figure 1). These models are designed to simplify the control and integration of these devices into subsystem and bench applications. These intelligent attenuators offer the same long reliable operation with exceptional accuracy and repeatability as with our other 150 Series Programmable Attenuators. They provide programmable adjustments of RF signal levels in precise steps of 1 dB, 5 dB, 10 dB, or with custom steps available. Each attenuator consists of a cascaded assembly of switched attenuator cells and a internal TTL interface.

The attenuator elements located in the attenuator cell are created by a thin-film process which provides exceptional long-term stability, low power and temperature coefficients. This series of step attenuators uses a reed switching structure that provides rapid switching together with low insertion loss.

BUILT-IN DRIVER CIRCUITRY: These programmable attenuators feature an internal microcontroller-based driver that provides a TTL-level digital interface for control of the attenuator relays. This card simplifies operation and interfacing requirements, while at the same time providing for greatly enhanced flexibility over past designs. User selectable modes of operation include both parallel and serial bus. The parallel mode provides a simple, one-bit per relay on/off control with internal pullups for use primarily in single attenuator applications. This mode allows the attenuator to be controlled via a variety of methods, such as a TTL-level digital output port, or mechanical toggle switches. The device bus provides a two-wire serial bus structure and protocol for connecting a number of devices to a single host control interface, suitable for use in larger system and sub-system applications. The driver interface contains non-volatile configuration memory that is used to hold a wide variety of attenuator and driver-dependent parameters, including serial number, attenuator cell dB values, relay configurations, and switching requirements, which are all accessible via the digital interface. This frees the system designer from such low-level details, allowing faster integration. In either operational mode, the microcontroller enters an idle condition during periods of inactivity, turning off all on-board clocks, reducing EMI concerns, and lowering power consumption. On-board regulation for the digital circuitry allows the programmable attenuator to operate from a single input supply voltage.

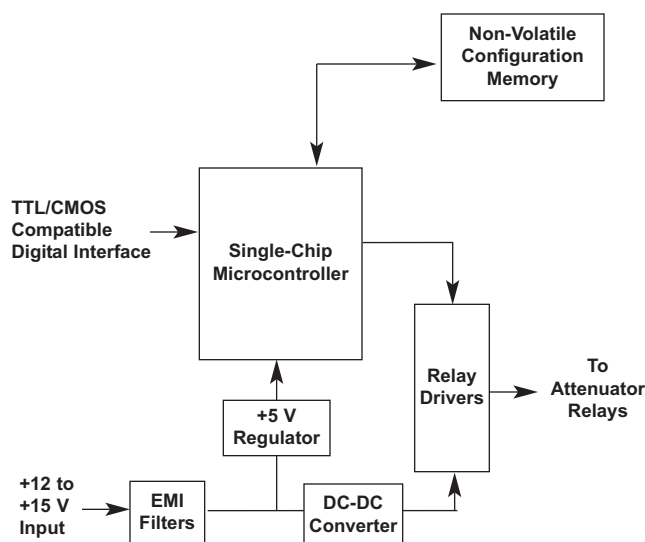

Figure 1. Built-In Driver Circuitry

Other features include:

- /// Wide Variety of Frequency & Attenuation Ranges
- /// Broadband Frequency Coverage
- /// High Accuracy and Repeatability
- /// Long Life, 5 Million Cycles Per Cell
- /// Common 14 pin Interface Connector
- /// Custom Attenuation Ranges

For additional information on the 150 Series, visit our website @ www.aeroflex.com/AW/programmables.htm

Programmable Attenuators



Specifications

NOMINAL IMPEDANCE: 50 Ω

FREQUENCY RANGE: Model 151T: dc to 4 GHz
 Model 150T: dc to 18 GHz
 Model 152T: dc to 26.5 GHz

CELL CONFIGURATIONS:

Cell	11	15	31	55	62	70	70	75	90	110
1	1	1	1	5	2	10	10	5	10	10
2	4	8	16	10	32	20	40	40	30	40
3	2	2	2	20	16	20	20	20	20	20
4	4	4	8	20	4	20	--	10	30	40
5	--	--	4	--	8	--	--	--	--	--

DRIVER INTERFACE:

Input Supply Voltage: +12.0 to +15.0V

Control Signals: TTL/CMOS compatible

Interface Modes: parallel / serial

DC Characteristics (at 25 °C):

Digital Interface:

Parameter	Specification
V _{IL} Low Level input:	-0.5 min, 0.8V max
V _{IH} High Level input:	2.0 min, 5.25V max
I _{PU} Pullup Current	50 μA min, 400 μA max

Power Supply:

V _{IN} Supply Voltage:	+12.0 to +15.0V
I _{IN} Supply current:	25 mA
I _{CELL} Supply Current:	150 mA (per cell, switching)

POWER RATING: 1 watt average, 100 watts peak
 (5 μsec pulse width; 0.5% duty cycle)

TEMPERATURE: -20° to +70°C operating

TEMPERATURE COEFFICIENT: <0.0001 dB/dB/C

POWER SENSITIVITY: <0.001 dB/dB/ Watt

RATED SWITCH LIFE: 5 million cycles per cell

RF INPUT CONNECTORS: Rugged female 3.5 mm which mate nondestructively with SMA male connectors per MIL-STD-39012.

INTERFACE CONNECTOR: 14 pin .025 square post header on .1 center. Mates with Amp connector 746285-2 or equivalent (one mating connector included with each unit).

SWITCHING TIME: 20 msec (includes settling time)

CYCLING RATE: 4 Hz max per relay

CONTROL PULSE WIDTH: 20 msec (minimum)

REPEATABILITY: ±0.1 dB typical per cell

VIBRATION*: MIL-STD-202F, Method 204D Cond B

ALTITUDE*: MIL-STD-202F, Method 105C Cond B, 50,000 Ft.

SHOCK*: MIL-STD -202F, Method 213B Cond B, except 10G, 6 msec

HUMIDITY*: MIL-STD-202F, Method 103B, Cond. B (96 Hrs. @ 95%, RH).

MAXIMUM SWR (50 Ω Characteristic Impedance):

APPLICABLE MODELS	Frequency (GHz)		
	dc-4	4-18	18-26.5
151T-11, 151T-15, 151T-31, 151-62T, 151T-75, 151T-110	1.50	---	---
150T-11, 150T-15, 150T-31 150T-62, 150T-75, 150T-110	1.50	1.90	---
151T-70 (3 cell)	1.40	---	---
150T-70 (3 cell)	1.40	1.60	---
152AT-70 (3 cell)	1.40	1.60	1.90
152T-55, 152T-70, 152-75, 152T-90	1.40	1.60	1.90

MAXIMUM INSERTION LOSS (dB):

APPLICABLE MODELS	Frequency (GHz)		
	dc-4	4-18	18-26.5
151T-11, 151T-15, 151T-75, 151T-110	0.90	---	---
150T-11, 150T-15, 150T-75, 150T-110	0.90	2.20	---
151T-31, 151T-62 (5 cell)	1.10	----	----
150T-31, 150T-62 (5 cell)	1.10	2.60*	----
151T-70 (3 cell)	0.70	---	---
150T-70 (3 cell)	0.70	1.60	---
152AT-70 (3 cell)	0.90	2.00	2.98
152T-55, 152T-70, 152T-75, 152T-90	0.90	2.00	2.98

*4-12.4 is 1.80, 12.4-18 is 2.60

WEIGHT: 5 Cell 350 g (12 oz)
 4 Cell 290 g (9.0 oz)
 3 Cell 230 g (8.0 oz)

ACCESSORIES

Programmable Attenuator/Switch Controller: The Model 8210A Programmable Attenuator/Switch Controller provides a flexible, low cost solution for the operation of programmable step attenuators and other electromechanical devices under computer control. Designed to interface to Aeroflex / Weinschel's intelligent programmable attenuators, the 8210A represents a new concept in device control applications for bench test and subsystem designs. The 8210A provides a high-level interface from various industry standard communications interfaces, including IEEE-488 and RS232/RS422/RS485, to the programmable attenuator's serial Driver Interface Bus.

OPTIONAL TEST DATA: Test Data is available at an additional cost for all programmable step attenuators models. Sweep Data across the programmable attenuator's frequency band starting at 0.05 to 18.0/26.5 GHz for all primary cells with markers at 0.05, 4.0, 8.0, 12.4, 18.0 and 26.5 GHz. VSWR and Attenuation provided.

ATTENUATION ACCURACY (\pm dB with respect to 0 dB reference):

Model 150T/151T/152T-11 & 150T/151T/152T-15:

Frequency Range (GHz)	Attenuation Setting (dB)														
	1	2	3	4	5	6	7	8	9	10	11	12	13	14	15
dc-4	0.2	0.2	0.3	0.3	0.3	0.3	0.4	0.4	0.4	0.4	0.5	0.5	0.5	0.5	0.5
4-12.4	0.3	0.3	0.4	0.4	0.5	0.5	0.6	0.6	0.6	0.6	0.7	0.7	0.7	0.7	0.7
12.4-18	0.5	0.6	0.6	0.6	0.6	0.7	0.7	0.7	0.7	0.8	0.8	0.8	0.8	0.8	0.8
18-26.5	0.5	0.6	0.7	0.8	0.9	0.9	0.9	1.0	1.1	1.1	1.1	1.1	1.1	1.1	1.1

Model 150T/151T-75:

Frequency Range (GHz)	Attenuation Setting (dB)														
	5	10	15	20	25	30	35	40	45	50	55	60	65	70	75
dc-4	0.2	0.2	0.4	0.4	0.5	0.5	0.7	0.7	0.9	0.9	1.1	1.1	1.2	1.2	1.4
4-12.4	0.3	0.3	0.6	0.6	0.9	0.9	1.2	1.2	1.5	1.5	1.8	1.8	2.1	2.1	2.1
12.4-18	0.4	0.4	0.8	0.8	1.2	1.2	1.6	1.6	2.0	2.0	2.4	2.4	2.8	2.8	2.8

Model 150T/151T-31:

Frequency Range (GHz)	Attenuation Setting (dB)															
	1	2	3	4	5	6	7	8	9	10	11	12	13	14	15	16
dc-4	0.2	0.2	0.3	0.3	0.3	0.3	0.4	0.4	0.5	0.4	0.5	0.5	0.5	0.5	0.5	0.5
4-12.4	0.4	0.4	0.5	0.5	0.6	0.6	0.7	0.6	0.7	0.6	0.7	0.7	0.7	0.7	0.7	0.7
12.4-18	0.5	0.5	0.6	0.6	0.6	0.6	0.7	0.7	0.8	0.8	0.8	0.8	0.8	0.8	0.8	0.8

Frequency Range (GHz)	Attenuation Setting (dB)																
	17	18	19	20	21	22	23	24	25	26	27	28	29	30	31		
dc-4	0.5	0.6	0.6	0.6	0.6	0.6	0.6	0.6	0.7	0.7	0.7	0.7	0.7	0.8	0.8		
4-12.4	0.8	0.8	0.9	0.9	0.9	0.9	0.9	0.9	1.1	1.0	1.0	1.0	1.0	1.1	1.1		
12.4-18	0.9	0.9	1.0	1.0	1.0	1.0	1.1	1.1	1.2	1.2	1.2	1.2	1.2	1.3	1.3		

Model 150T/151T-62:

Frequency Range (GHz)	Attenuation Setting (dB)															
	2	4	6	8	10	12	14	16	18	20	22	24	26	28	30	32
dc-4	0.3	0.3	0.3	0.4	0.4	0.5	0.5	0.5	0.5	0.5	0.5	0.5	0.5	0.5	0.6	0.6
4-12.4	0.4	0.4	0.4	0.5	0.5	0.6	0.6	0.6	0.7	0.7	0.7	0.8	0.8	0.8	0.8	0.8
12.4-18	0.5	0.5	0.5	0.6	0.6	0.6	0.8	0.8	0.8	0.8	0.8	1.0	1.0	1.0	1.2	1.2

Frequency Range (GHz)	Attenuation Setting (dB)														
	34	36	38	40	42	44	46	48	50	52	54	56	58	60	62
dc-4	0.6	0.6	0.7	0.7	0.7	0.8	0.8	0.8	0.9	0.9	0.9	1.0	1.0	1.0	1.2
4-12.4	1.0	1.0	1.1	1.1	1.3	1.4	1.4	1.4	1.5	1.6	1.6	1.6	1.8	1.8	1.8
12.4-18	1.4	1.4	1.6	1.6	1.8	1.8	2.0	2.0	2.0	2.2	2.2	2.2	2.4	2.4	2.4

Model 150T/151T/152T-75:

Frequency Range (GHz)	Attenuation Setting (dB)														
	5	10	15	20	25	30	35	40	45	50	55	60	65	70	75
dc-4	0.2	0.2	0.4	0.4	0.5	0.5	0.7	0.7	0.9	0.9	1.1	1.1	1.2	1.2	1.4
4-12.4	0.3	0.3	0.6	0.6	0.9	0.9	1.2	1.2	1.5	1.5	1.8	1.8	2.1	2.1	2.1
12.4-18	0.4	0.4	0.8	0.8	1.2	1.2	1.6	1.6	2.0	2.0	2.4	2.4	2.8	2.8	2.8
18 - 26.5	0.5	0.5	0.9	0.9	1.2	1.2	1.6	1.6	2.0	2.0	2.4	2.4	2.8	2.8	2.8

Model 150T/151T-70, 150T/151T-110, 152AT-70:

Frequency Range (GHz)	Attenuation Setting (dB)										
	10	20	30	40	50	60	70	80	90	100	110
dc-4	0.2	0.3	0.5	0.7	0.9	1.0	1.2	1.4	1.6	1.7	1.9
4-12.4	0.4	0.7	0.9	1.2	1.5	1.8	2.1	2.4	2.7	3.0	3.0
12.4-18	0.4	0.8	1.2	1.6	2.0	2.4	2.8	3.2	3.6	4.0	4.0
18-26.5	0.6	0.7	0.9	1.5	1.6	2.2	2.9	---	---	---	---

Model 152T-55:

Frequency Range (GHz)	Attenuation Setting (dB)										
	5	10	15	20	25	30	35	40	45	50	55
dc-4	0.2	0.3	0.4	0.4	0.4	0.6	0.6	0.7	0.7	0.8	1.0
4-12.4	0.3	0.4	0.5	0.5	0.5	0.7	0.8	0.9	0.9	1.0	1.3
12.4-18	0.4	0.4	0.5	0.5	0.5	0.8	1.0	1.1	1.1	1.2	1.6
18-26.5	0.5	0.5	0.6	0.6	0.6	0.9	1.2	1.4	1.4	1.5	2.0

Model 152T-70, 152T-90:

Frequency Range (GHz)	Attenuation Setting (dB)								
	10	20	30	40	50	60	70	80	90
dc-4	0.3	0.5	0.6	0.7	0.8	1.0	1.1	1.1	1.2
4-12.4	0.4	0.5	0.7	0.9	1.0	1.3	1.5	1.6	1.7
12.4-18	0.5	0.6	0.8	1.1	1.2	1.4	1.7	1.8	2.1
18-26.5	0.5	0.6	0.9	1.4	1.5	1.8	2.3	2.4	2.8

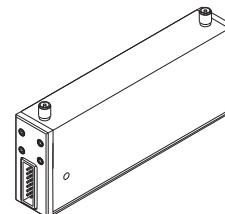

Programmable Attenuators



PHYSICAL DIMENSIONS:

Models 150T, 151T, & 152T:

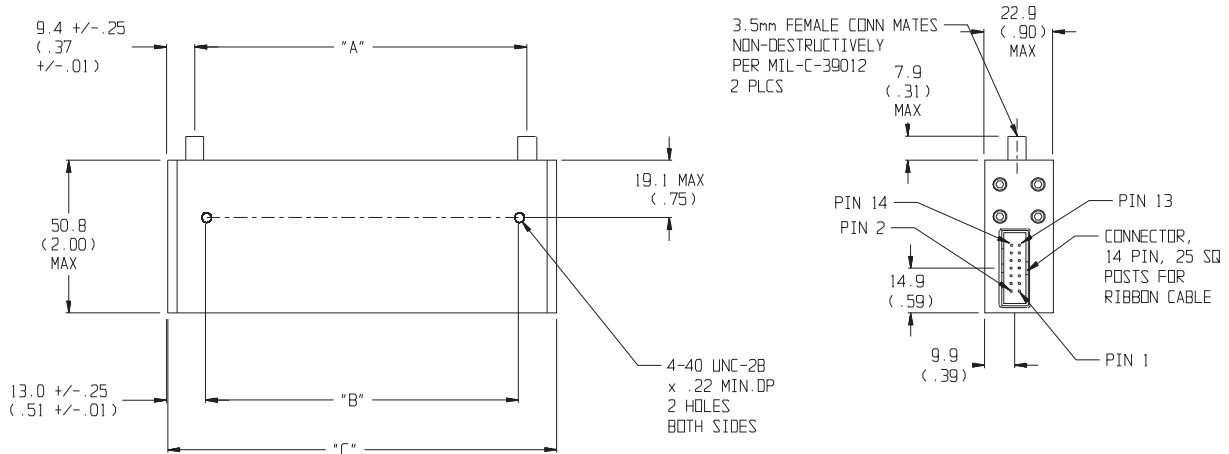

DIM	A	B	C
3 cell	83.3 (3.28)	76.2 (3.0)	101.6 (4.00)
4 cell	110.7 (4.36)	103.6 (4.08)	129.2 (5.09)
5 cell	136.1 (5.36)	129.1 (5.08)	154.4 (6.08)

NOTE:

1. All dimensions are given in mm (inches) and are maximum, unless otherwise specified.
2. Unit available with RoHS compliant materials, specify when ordering.

150T Series Ordering Guide...

Frequency Range	NO. Cells	Attenuator Range/Step Size									
		11/1 dB	15/1 dB	31/1 dB	55/5 dB	62/2 dB	70/10 dB	75/5 dB	90/10 dB	110/10 dB	
dc-4 GHz	4	151T-11	151T-15		N/A			151T-70	151T-75	N/A	151T-110
	3										
	5			151T-31		151T-62					
dc-18 GHz	4	150T-11	150T-15		N/A			150T-70	150T-75	N/A	150T-110
	3										
	5			150T-31		150T-62					
dc-26.5 GHz	4	N/A	NA	N/A	152T-55	NA	152T-70	152T-75	152T-90	N/A	
	3						152AT-70				

Model 150

Model 151

Model 152

Relay Switched Programmable Attenuators

dc to 18.0 GHz

dc to 4.0 GHz

dc to 26.5 GHz

 **RoHS**



Description

The Model 150, 151 and 152 Programmable Step Attenuators represent the widest variety of programmable attenuators available. This attenuator design is the result of an extensive development program and offers long reliable operation with exceptional accuracy and repeatability. These attenuators can provide programmable adjustments of RF signal levels in precise steps of 1 dB, 5 dB, 10 dB, or with custom steps available. Each attenuator consists of a cascaded assembly of switched attenuator cells (Figure 1). The attenuator elements located in the attenuator cell are created by a thin-film process which provides exceptional long-term stability, low power and temperature coefficients. This series uses a reed switching structure that provides rapid switching together with low insertion loss.

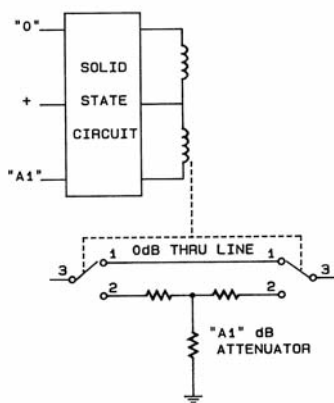

Figure 1. Cell Schematic

Other features include:

- /// Broadband Frequency Coverage
- /// High Accuracy and Repeatability
- /// Long Life, 5 Million Cycles Per Cell
- /// 3, 4, and 5 Cell Configurations

PROGRAMMABILITY: In each programmable step Attenuator, solenoids are used to switch the internal resistor card of each cell into and out of the circuit. Once the cell is switched, the solenoid is magnetically latched into position and is able to withstand extreme shock and vibration. Internal circuitry is included to interrupt the coil current after switching is complete. This reduces power dissipation even if power is continuously applied. The switching time for each cell is rated at 20 msec maximum which includes the contact settling time.

BROADBAND ACCURACY & LOW SWR: The use of Aeroflex / Weinschel's proprietary thin-film resistor process provides these programmable step attenuators with a high degree of accuracy and the lowest possible SWR uncertainty (refer to specifications for actual values). This thin film process permits the construction of circuits which are truly distributed and without stray reactances, even at the higher microwave frequencies.

RELIABILITY: Each programmable step attenuator is composed of 3 to 5 (4 in most models) cells. As with all mechanical designs, usable life becomes a primary concern to the user. With this in mind Aeroflex / Weinschel backs all these attenuators with a rated switch life of 5 million operations per cell. Standardized testing is also performed on each programmable step attenuator over its operating frequency range by a computer controlled Aeroflex / Weinschel Attenuation Measurement System which is traceable to NIST standards.

ENVIRONMENTAL: These Model 150 Programmable Step Attenuators have undergone an extensive environmental qualification program and have been subjected to temperature, shock, vibration, and humidity conditions per MIL-STD-202F. These programmable step attenuators operate within these specifications at an ambient temperature of -20° to +75°C. Operating beyond these limits will adversely affect the accuracy and could damage the internal circuitry.

For additional information on the 150 Series, visit our website @ www.aeroflex.com/AW/programmables.htm

150 Series Cell Configurations...

ATTN Value	Cells No.	Cell 1		Cell 2		Cell 3		Cell 4		Cell 5		Power +Vdc
		Bypass	ATTN Element	Bypass	ATTN Element	Bypass	ATTN Element	Bypass	ATTN Element	Bypass	ATTN Element	
11 dB	4	0 dB	1 dB	0 dB	4 dB	0 dB	2 dB	0 dB	4 dB	---	---	
15 dB	4	0 dB	1 dB	0 dB	8 dB	0 dB	2 dB	0 dB	4 dB	---	---	
31 dB	5	0 dB	1 dB	0 dB	8 dB	0 dB	2 dB	0 dB	16 dB	0 dB	4 dB	
62 dB	5	0 dB	2 dB	0 dB	32 dB	0 dB	16 dB	0 dB	4 dB	0 dB	8 dB	
55 dB	4	0 dB	5 dB	0 dB	10 dB	0 dB	20 dB	0 dB	20 dB	---	---	
70 dB	4	0 dB	10 dB	0 dB	20 dB	0 dB	20 dB	0 dB	20 dB	---	---	
	3	0 dB	10 dB	0 dB	40 dB	0 dB	20 dB	---	---	---	---	
75 dB	4	0 dB	5 dB	0 dB	40 dB	0 dB	20 dB	0 dB	10 dB	---	---	
90 dB	4	0 dB	10 dB	0 dB	30 dB	0 dB	20 dB	0 dB	30 dB	---	---	
110 dB	4	0 dB	10 dB	0 dB	40 dB	0 dB	20 dB	0 dB	40 dB	---	---	
Round Conn.	PIN #	5	6	9	10	7	8	11	12	3	4	1
3 & 4 Cell	Wire Color	Violet	Yellow	Orange	Blue	Black	Green	Brown	White	---	---	Red
5 Cell	Wire Color	Black	White	Green	Orange	Blue	WHT/BLK	RED/BLK	GRN/BLK	ORN/BLK	BLU/BLK	Red
Ribbon Cable Conn.	PIN#	13	2	3	9	11	5	4	10	8	7	6
	Wire Color	Orange	Yellow	Blue	Brown	Purple	Black	Gray	White	Orange	yellow	Red

Table provides standard attenuation ranges, increments, and cell configurations for all Aeroflex / Weinschel Programmable Step Attenuators (Models 150, 151, 152, & 152A)

Specifications

NOMINAL IMPEDANCE: 50 Ω

FREQUENCY RANGE: Model 151: dc to 4 GHz
 Model 150: dc to 18 GHz
 Model 152: dc to 26.5 GHz

OPERATIONAL VOLTAGE: + 24V Nominal (+20V minimum to +30V maximum) or +5V Nominal (+4V minimum* to +7V maximum)

*Minimum operating voltage derated to +4.25 V @ 55°C and further derated to +4.5 V @ 75°C

POWER RATING: 1 watt average, 100 watts peak (5 μsec pulse width; 0.5% duty cycle)

TEMPERATURE: -20° to +75°C operating

TEMPERATURE COEFFICIENT: < 0.0001 dB/dB/°C

POWER SENSITIVITY: < 0.001 dB/dB/ Watt

RATED SWITCH LIFE: 5 million cycles per cell

RF INPUT CONNECTORS: Rugged female 3.5 mm connectors which mate nondestructively with SMA male connectors per MIL-STD-39012.

CONTROL CONNECTOR: 12 pin Viking TNP12-101 connector with 5' cable or 14 conductor 16" ribbon cable with connector (shown below):

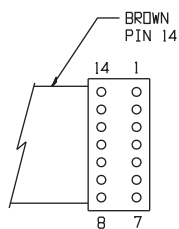

Ribbon Cable Models

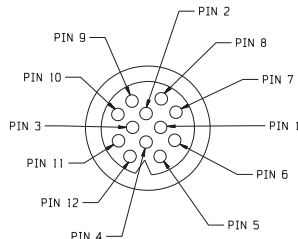

Round (Viking) Cable Models

SWITCHING TIME: 20 msec (includes settling time)

CYCLING RATE: 4 Hz max per relay

CONTROL PULSE WIDTH: 20 msec (minimum)

SWITCHING CURRENT: 125 mA @ +24V per cell
 300 mA @ +5V per cell

REPEATABILITY: ±0.1 dB typical per cell

VIBRATION: MIL-STD-202F, Method 204D Cond B

ALTITUDE: MIL-STD-202F, Method 105C Cond B, 50,000 Ft.

SHOCK: MIL-STD -202F, Method 213B Cond B, except 10G, 6 msec

HUMIDITY: MIL-STD-202F, Method 103B, Cond. B (96 Hrs. @ 95%, RH)

EMC: Radiated interference is within the requirements of MIL-STD-461 method RE02, VDE 0871 and CISPR Publication II.

WEIGHT: 5 Cell 350 g (12 oz)
 4 Cell 290 g (9.0 oz)
 3 Cell 230 g (8.0 oz)

VOLTAGE/CONNECTOR OPTIONS:

VOLTAGE	MODEL(S)
+ 24 V with Viking Connector	150-XX, 151-XX, 152-XX, 152A-XX
+ 24 V with Ribbon Cable	150-XX-1, 151-XX-1, 152-XX-1, 152A-XX-1
+ 5 V with Viking Connector	150-XX-2, 151-XX-2, 152-XX-2, 152A-XX-2
+ 5 V with Ribbon Cable	150-XX-3, 151-XX-3, 152-XX-3, 152A-XX-3

MAXIMUM SWR (50 Ω Characteristic Impedance):

APPLICABLE MODELS	Frequency (GHz)		
	dc-4	4-18	18-26.5
151-11, 151-15, 151-31, 150-62, 151-75, 151-110	1.50	---	---
150-11, 150-15, 150-31, 151-62, 150-75, 150-110	1.50	1.90	---
151-70 (3 cell)	1.35	---	---
150-70 (3 cell)	1.35	1.70	---
152A-70 (3 cell)	1.40	1.70	1.80
152-55, 152-70, 152-90, 152-110	1.40	1.60	1.90

MAXIMUM INSERTION LOSS (dB):

APPLICABLE MODELS	Frequency (GHz)		
	dc-4	4-18	18-26.5
151-11, 151-15, 151-75, 151-110	0.90	---	---
150-11, 150-15, 150-75, 150-110	0.90	2.20	---
151-31, 150-62 (5 cell)	1.10	---	---
150-31, 151-62 (5 cell)	1.10	2.60*	---
151-70 (3 cell)	0.70	---	---
150-70 (3 cell)	0.70	1.60	---
152A-70 (3 cell)	0.90	2.00	2.98
152-55, 152-70, 152-90, 152-110	0.90	2.00	2.98

*4-12.4 is 1.80, 12.4-18 is 2.60

ATTENUATION ACCURACY (±dB with respect to 0 dB reference):

Model 150/151/152-11 & 150/151/152-15:

Frequency Range (GHz)	Attenuation Setting (dB)														
	1	2	3	4	5	6	7	8	9	10	11	12	13	14	15
dc-4	0.2	0.2	0.3	0.3	0.3	0.3	0.4	0.4	0.4	0.4	0.5	0.5	0.5	0.5	0.5
4-12.4	0.3	0.3	0.4	0.4	0.5	0.5	0.6	0.6	0.6	0.6	0.7	0.7	0.7	0.7	0.7
12.4-18	0.5	0.6	0.6	0.6	0.6	0.7	0.7	0.7	0.7	0.8	0.8	0.8	0.8	0.8	0.8
18-26.5	0.5	0.6	0.7	0.8	0.9	0.9	0.9	1.0	1.1	1.1	1.1	1.1	1.1	1.1	1.1

Model 150/151-75:

Frequency Range (GHz)	Attenuation Setting (dB)														
	5	10	15	20	25	30	35	40	45	50	55	60	65	70	75
dc-4	0.2	0.2	0.4	0.4	0.5	0.5	0.7	0.7	0.9	0.9	1.1	1.1	1.2	1.2	1.4
4-12.4	0.3	0.3	0.6	0.6	0.9	0.9	1.2	1.2	1.5	1.5	1.8	1.8	2.1	2.1	2.1
12.4-18	0.4	0.4	0.8	0.8	1.2	1.2	1.6	1.6	2.0	2.0	2.4	2.4	2.8	2.8	2.8

Model 150/151-31:

Frequency Range (GHz)	Attenuation Setting (dB)															
	1	2	3	4	5	6	7	8	9	10	11	12	13	14	15	16
dc-4	0.2	0.2	0.3	0.3	0.3	0.3	0.4	0.4	0.5	0.4	0.5	0.5	0.5	0.5	0.5	0.5
4-12.4	0.4	0.4	0.5	0.4	0.6	0.6	0.7	0.6	0.7	0.6	0.7	0.7	0.7	0.7	0.7	0.7
12.4-18	0.5	0.5	0.6	0.6	0.6	0.6	0.7	0.7	0.8	0.8	0.8	0.8	0.8	0.8	0.8	0.8

Frequency Range (GHz)	Attenuation Setting (dB)														
	17	18	19	20	21	22	23	24	25	26	27	28	29	30	31
dc-4	0.5	0.6	0.6	0.6	0.6	0.6	0.6	0.6	0.7	0.7	0.7	0.7	0.7	0.8	0.8
4-12.4	0.8	0.8	0.9	0.9	0.9	0.9	0.9	0.9	1.1	1.0	1.0	1.0	1.0	1.1	1.1
12.4-18	0.9	0.9	1.0	1.0	1.0	1.0	1.1	1.1	1.2	1.2	1.2	1.2	1.2	1.3	1.3

Model 150/151-62:

Frequency Range (GHz)	Attenuation Setting (dB)															
	2	4	6	8	10	12	14	16	18	20	22	24	26	28	30	32
dc-4	0.3	0.3	0.3	0.4	0.4	0.5	0.5	0.5	0.5	0.5	0.5	0.5	0.5	0.5	0.6	0.6
4-12.4	0.4	0.4	0.4	0.5	0.5	0.6	0.6	0.6	0.7	0.7	0.7	0.8	0.8	0.8	0.8	0.8
12.4-18	0.5	0.5	0.5	0.6	0.6	0.6	0.8	0.8	0.8	0.8	0.8	1.0	1.0	1.0	1.2	1.2

Frequency Range (GHz)	Attenuation Setting (dB)														
	34	36	38	40	42	44	46	48	50	52	54	56	58	60	62
dc-4	0.6	0.6	0.7	0.7	0.7	0.8	0.8	0.8	0.9	0.9	0.9	1.0	1.0	1.0	1.2
4-12.4	1.0	1.0	1.1	1.1	1.3	1.4	1.4	1.4	1.5	1.6	1.6	1.6	1.8	1.8	1.8
12.4-18	1.4	1.4	1.6	1.6	1.8	1.8	2.0	2.0	2.0	2.2	2.2	2.2	2.4	2.4	2.4

Model 150/151-70, 150/151/152-110, 152A-70:

Frequency Range (GHz)	Attenuation Setting (dB)										
	10	20	30	40	50	60	70	80	90	100	110
dc-4	0.2	0.3	0.5	0.7	0.9	1.0	1.2	1.4	1.6	1.7	1.9
4-12.4	0.4	0.7	0.9	1.2	1.5	1.8	2.1	2.4	2.7	3.0	3.0
12.4-18	0.4	0.8	1.2	1.6	2.0	2.4	2.8	3.2	3.6	4.0	4.0
18-26.5	0.5	0.9	1.3	2.0	2.2	2.6	3.2	3.6	4.0	4.2	4.6

Model 152-55:

Frequency Range (GHz)	Attenuation Setting (dB)										
	5	10	15	20	25	30	35	40	45	50	55
dc-4	0.2	0.3	0.4	0.4	0.4	0.6	0.6	0.7	0.7	0.8	1.0
4-12.4	0.3	0.4	0.5	0.5	0.5	0.7	0.8	0.9	0.9	1.0	1.3
12.4-18	0.4	0.4	0.5	0.5	0.5	0.8	1.0	1.1	1.1	1.2	1.6
18-26.5	0.5	0.5	0.6	0.6	0.6	0.9	1.2	1.4	1.4	1.5	2.0

Model 152-70 & 152-90:

Frequency Range (GHz)	Attenuation Setting (dB)								
	10	20	30	40	50	60	70	80	90
dc-4	0.3	0.5	0.6	0.7	0.8	1.0	1.1	1.1	1.2
4-12.4	0.4	0.5	0.7	0.9	1.0	1.3	1.5	1.6	1.7
12.4-18	0.5	0.6	0.8	1.1	1.2	1.4	1.7	1.8	2.1
18-26.5	0.5	0.6	0.9	1.4	1.5	1.8	2.3	2.4	2.8

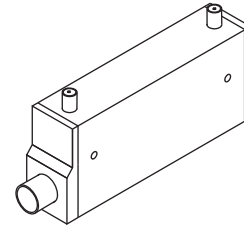

Programmable Attenuators



PHYSICAL DIMENSIONS:

Models 150, 151, & 152:

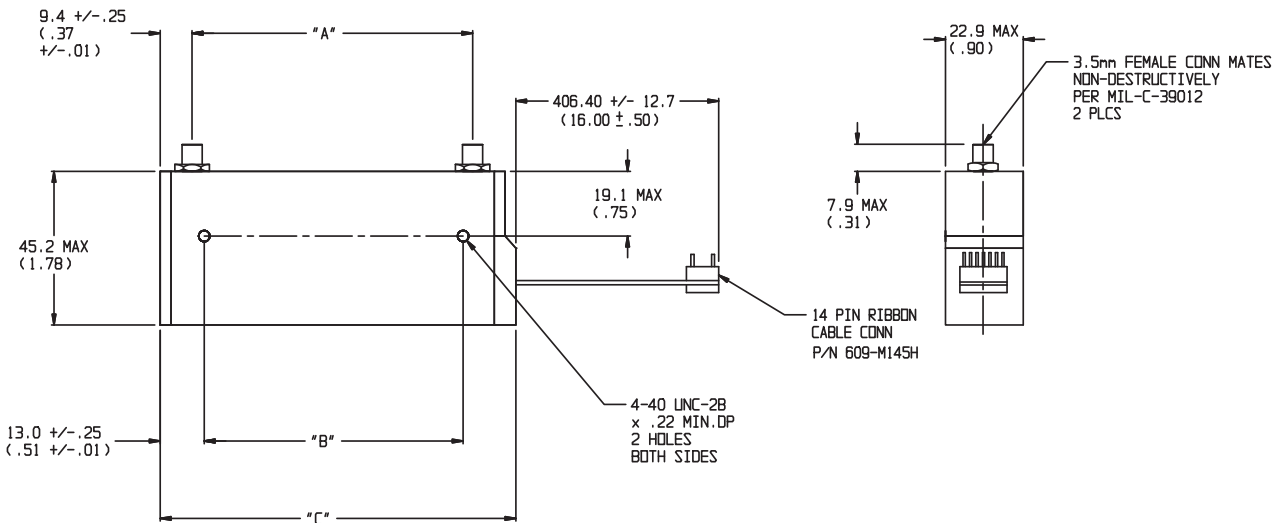
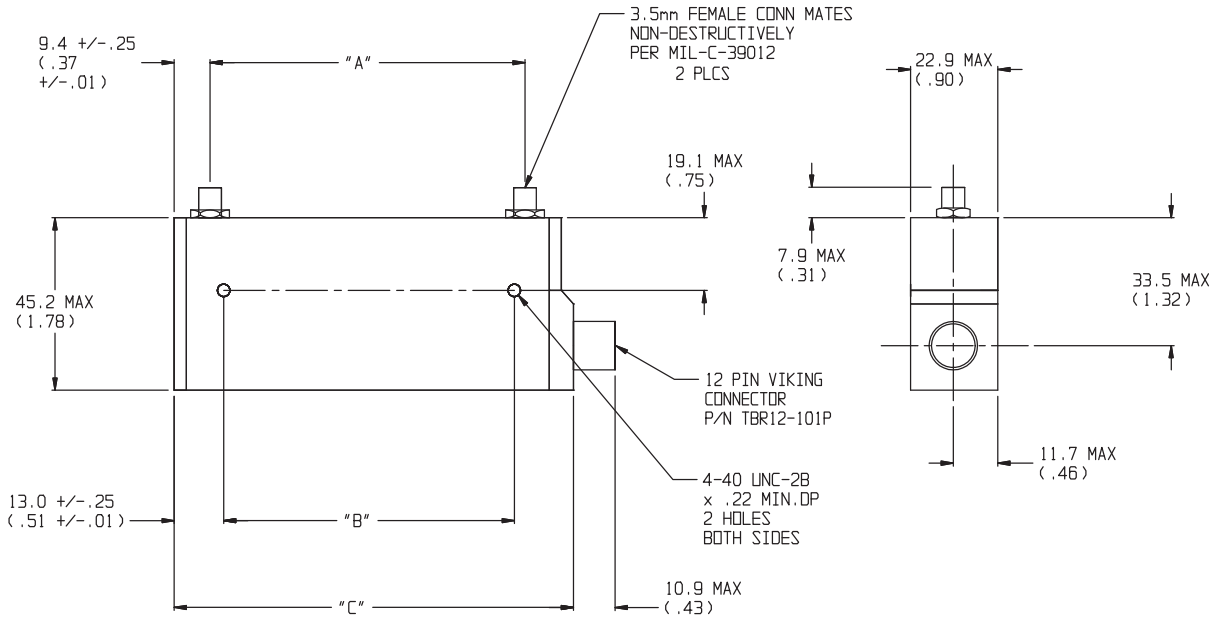

DIM	A	B	C
3 cell	82.3 (3.28)	76.2 (3.0)	105.7 (4.16)
4 cell	110.7 (4.36)	103.7 (4.08)	133.6 (5.25)
5 cell	136.1 (5.36)	129.1 (5.08)	159.5 (6.28)

NOTE:

1. All dimensions are given in mm (inches) and are maximum, unless otherwise specified.
2. Unit available with RoHS compliant materials, specify when ordering.

150 Series Ordering Guide...

Frequency Range/ Voltage/Connector	NO. Cells	Attenuator Range/Step Size								
		11/1 dB	15/1 dB	55/5 dB	31/1 dB	62/2 dB	70/10 dB	75/5 dB	90/10 dB	110/10 dB
dc-4 GHz/+24 V/ Viking Connector	4 3 5	151-11	NA	N/A			N/A	151-75	N/A	151-110
dc-18 GHz/+24 V/ Viking Connector	4 3 5	150-11	150-15	N/A			150-70	150-75	N/A	150-110
dc-26.5 GHz/+24 V/ Viking Connector	4 3	N/A	N/A	152-55			N/A	N/A	152-90	N/A
dc-4 GHz/+24 V/ Ribbon Cable	4 3 5	151-11-1	NA	N/A			N/A	151-75-1	N/A	151-110-1
dc-18 GHz/+24 V/ Ribbon Cable	4 3 5	150-11-1	150-15-1	N/A			150-70-1	N/A	N/A	150-110-1
dc-26.5 GHz/+24 V/ Ribbon Cable	4 3	N/A	N/A	152-55-1			N/A	N/A	152-90-1	152-110-1
dc-4 GHz/+5 V/ Viking Connector	4 3 5	151-11-2	151-15-2	N/A			N/A	151-75-2	N/A	151-110-2
dc-18 GHz/+5 V/ Viking Connector	4 3 5	150-11-2	150-15-2	N/A			150-70-2	150-75-2	N/A	150-110-2
dc-26.5 GHz/+5 V/ Viking Connector	4 3	N/A	N/A	152-55-2			N/A	N/A	152-90-2	152-110-2
dc-4 GHz/+5 V/ Ribbon Cable	4 3 5	151-11-3	N/A	N/A			N/A	N/A	N/A	N/A
dc-18 GHz/+5 V/ Ribbon Cable	4 3 5	150-11-3	150-15-3	N/A			150-70-3	150-75-3	N/A	150-110-3
dc-26.5 GHz/+5 V/ Ribbon Cable	4 3	N/A	N/A	152-55-3			N/A	N/A	152-90-3	152-110-3

N/A = Not Available

ACCESSORIES

OPTIONAL TEST DATA: Test Data is available at an additional cost for all programmable step attenuators models. Sweep Data across the programmable attenuator's frequency band starting at 0.05 to 18.0/26.5 GHz for all primary cells with markers at 0.05, 4.0, 8.0, 12.4, 18.0 and 26.5 GHz. VSWR and Attenuation provided.

MODELS WITH BUILT-IN TTL/CMOS INTERFACE/ DRIVER CIRCUIT: Aeroflex / Weinschel offers versions of the 150 series with built-in TTL/CMOS interfaces. This generation of intelligent attenuators will greatly simplify as well as provide an economical solution to 150 series driver problems. Refer to Model 150T, 151T, and 152T data sheet for more information.

Programmable Attenuators



Model 153 Programmable Step Attenuator

dc to 40.0 GHz
1 Watt



Advanced Technology & Performance



Features

- /// Higher Frequency range to 40 GHz.
- /// Choice of Attenuation Ranges
 - 0 to 70 dB in 10 dB steps
 - 0 to 110 dB in 10 dB steps
- /// Lowest insertion loss & Excellent Repeatability
- /// Life of 5 million operations
- /// Small rugged construction & light weight

Description

This series of Programmable Step Attenuators provide attenuation from 0-70 dB or 0-110 dB in 10 dB steps. These attenuators provide programmable adjustments of RF signal levels in precise steps of 10 dB and consist of a cascaded assembly of switched attenuator cells (Figure 1). The attenuator elements located in the attenuator cell are created by a thin-film process which provides exceptional long-term stability, low power and temperature coefficients. This series uses a reed switching structure that provides rapid switching together with low insertion loss. The 153 series is available in three cell (153-70) and four cell (153-110) configurations.

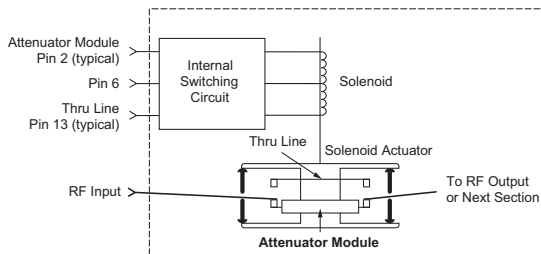

Figure 1. Cell Schematic

All models use in-line, female SMK (2.92mm) Connectors and contain a 14 pin Dip control connector that is plug-compatible with other competitive units.

PROGRAMMABILITY: In each programmable step attenuator, solenoid are used to switch the internal resistor card of each cell into and out of the circuit. With positive voltage applied to the common pin (#6) the state (attenuator card or thru line) of a particular section is determined by connecting it's attenuator card or thru pin to ground. Once the cell is switched, the solenoid is magnetically latched into position and is able to withstand extreme shock and vibration. Internal circuitry is included to interrupt the coil current after switching is complete. This reduces power dissipation even if power is continuously applied. The switching time for each cell is rated at 20 msec maximum which includes the contact settling time.

Also integrated in the design is solid state dc switching circuitry that avoids the relatively high failure rate of mechanical DC switches. Each attenuator section is controlled by its own driver circuit, which requires +24V nominal, 125 mA.

Specifications

NOMINAL IMPEDANCE: 50 Ω
FREQUENCY RANGE: dc to 40.0 GHz

MAXIMUM SWR (50 Ω Characteristic Impedance):	
Frequency Range (GHz)	SWR
dc - 8	1.30
8 - 12	1.50
12 - 20	1.60
20 - 26.5	1.80
26.5 - 40	2.10

CELL CONFIGURATIONS:			
Model Number	NO. Cells	Attenuation Range/Steps (dB)	Cell Increments (dB)
153-70	3	70/10	10, 20, 40
153-110	4	110/10	10, 20, 40, 40

For additional information on the 150 Series, visit our website @ www.aeroflex.com/AW/programmables.htm

Specifications - Con't

MAXIMUM INSERTION LOSS (dB):

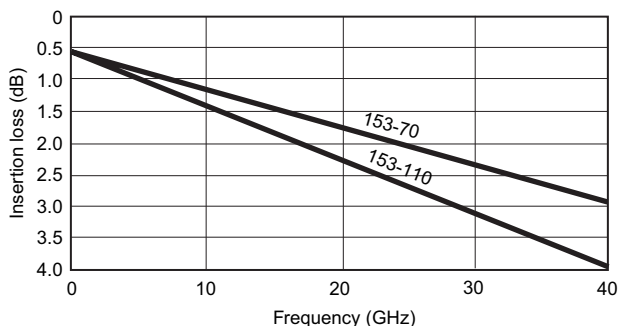

ATTENUATOR ACCURACY (\pm dB):

Frequency Range (GHz)	Attenuation (dB)							
	10	20	30	40	50	60	70	80-110
DC - 8	0.3	0.5	0.6	0.7	0.8	1.0	1.1	1.4
8 - 12	0.4	0.5	0.7	0.9	1.0	1.3	1.5	2.0
12 - 20	0.5	0.6	0.8	1.1	1.2	1.4	1.7	2.2
20 - 26.5	0.7	0.8	1.0	1.5	1.6	1.9	2.3	2.8
26.5 - 40	0.9	1.0	1.2	1.7	1.9	2.3	2.6	3.2

SWITCHING SPEED: 20 msec. maximum

OPERATING VOLTAGE: +24V nominal, +20V minimum; +30V maximum

SWITCHING CONTROL CURRENT: 125 mA typical per cell @ +24V nominal, Model 153-70 (3 cells) and 153-110 (4 cells).

SOLENOID COIL IMPEDANCE: 190 Ω

SOLENOID COIL INDUCTANCE: 65 mH

POWER RATING: 1 watt average, 100 watts peak (5 μ sec pulse width, 0.5% duty cycle)

RF POWER SENSITIVITY: 0.001 dB/dB/W

SWITCH LIFE: 5 million (minimum operations per cell)

PHYSICAL DIMENSIONS:

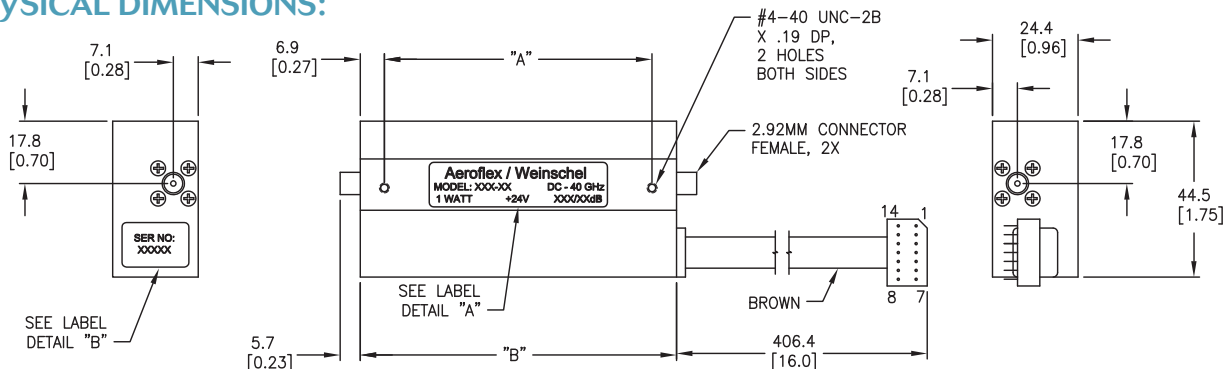

Model No.	No. Cells	A	B
153-70	3	76.2 (3.0)	90.2 (3.55)
153-110	4	102.9 (4.05)	115.8 (4.6)

NOTE: All dimensions are given in mm (inches) and are nominal, unless otherwise specified.

Programmable Attenuators

REPEATABILITY:

- ± 0.03 dB to 18 GHz
- ± 0.05 dB to 26.5 GHz
- ± 0.08 dB to 40 GHz

TEMPERATURE RANGE:

- Operating: -0°C to $+70^{\circ}\text{C}$
- Non-Operating: -55°C to $+85^{\circ}\text{C}$

ALTITUDE: Operating: 4.6 km (440 mm Hg)
Non-operating: 15 km

SHOCK: Operating: 10g, 6 ms, on 6 sides, 3 blows
Non-operating: 500 g, 1.8 ms, in 6 directions

HUMIDITY: 0 to 95% relative humidity

EMC: MIL-STD-461, Method RE02, VDE 0871, CISPR#2

TEST DATA: Test data is available at additional cost.

CONNECTORS: 2.92mm connectors - mate nondestructively with SMA connectors per MIL-C-39012, 3.5mm, SMK, and other 2.92mm connectors.

CONTROL CONNECTOR: 14 conductor 16" ribbon cable with connector (shown below):

Pin Number	Wire Color	153-70	153-110
1	---	---	---
2	White	10 dB Cell Attenuator	10 dB Cell Attenuator
3	Violet	40 dB Cell Thru Line	40 dB Cell 1 Thru Line
4	Green	---	40 dB Cell 2 Thru Line
5	Orange	20 dB Cell Attenuator	20 dB Cell Attenuator
6	Brown	+24Vdc	+24Vdc
7	---	---	---
8	---	---	---
9	Red	40 dB Cell Attenuator	40 dB Cell 1 Attenuator
10	Yellow	---	40 dB Cell 2 Attenuator
11	Blue	20 dB Cell Thru Line	20 dB Cell Thru Line
12	Grey	---	---
13	Black	10 dB Cell Thru Line	10 dB Cell Thru Line
14	---	---	---

WEIGHT (Typical): 153-70: 170 g (6 oz)
153-110: 213 g (7.5 oz)

Programmable Attenuators



Model 4202 Digital Attenuator with Built-in TTL Driver

0.4 to 6 GHz



Features

- /// Ideal for Automated Test Equipment (ATE), WiMAX, 3G Fading Simulators, Engineering/Production Test Lab environments
- /// Excellent Repeatability & Performance
- /// Custom Configurations Available Upon Request
- /// Ruggedized Construction

Description

Aeroflex / Weinschel's new line of MMIC Digital Attenuator operates over the 0.4 to 6 GHz frequency range and provides an attenuation range from 0 to 63 in 1 dB increments.

Specifications

NOMINAL IMPEDANCE:	50 Ω
FREQUENCY RANGE:	0.4 to 6.0 GHz
ATTENUATION RANGE/STEPS:	0-63 in 1 dB steps
ATTENUATION INCREMENTS:	1, 2, 4, 8, 16, 32 dB
ATTENUATION ACCURACY:	± 1 dB or 4%
INSERTION LOSS:	7.0 dB maximum
MAXIMUM SWR:	2.0:1
POWER RATING:	20 dBm (100 mW) maximum
SWITCHING SPEED:	300 nsec maximum
CONTROL LOGIC:	TTL
OPERATING VOLTAGE:	+5 V @ 20 mA
TEMPERATURE RANGE:	0°C to + 70°C

TEST DATA: Test data can be provided at additional cost.

CONNECTORS: SMA female connector - mates nondestructively with other SMA connector per MIL-C-39012, 3.5mm and other 2.92mm connector.

CONTROL CONNECTOR: AMP-Latch 10 pin ribbon cable connector mates with AMP P/N 746285-1 (supplied with each unit)

CONTROL CONFIGURATION: Units are supplied with a built-in TTL interface. Each unit is supplied with a mating 10 pin connector (Amp 746285-1). Refer to Physical Dimensions for mating connector pin/wiring details. Two wires are specified for supply voltage and ground. The remaining wires will accept TTL control signals to activate or de-activate a particular attenuation cell. A TTL high will energize a cell to the high attenuation state, whereas a TTL low will maintain a cell in its zero attenuation state.

WEIGHT: 83 g (2.92 oz)

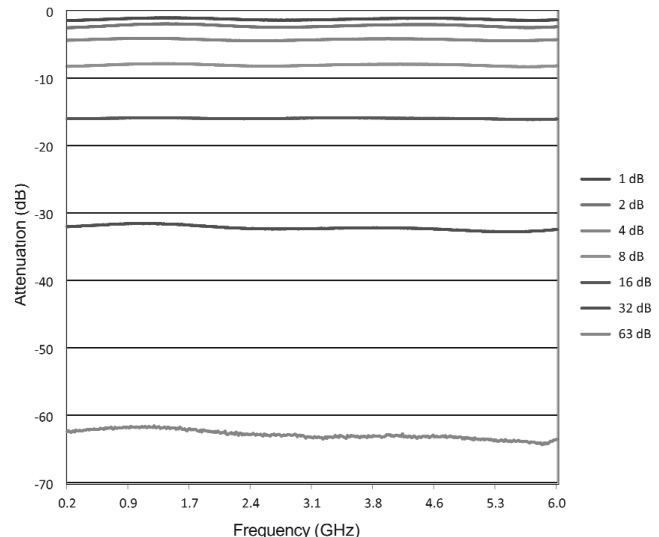

Attenuation Performance Plot

PHYSICAL DIMENSIONS:

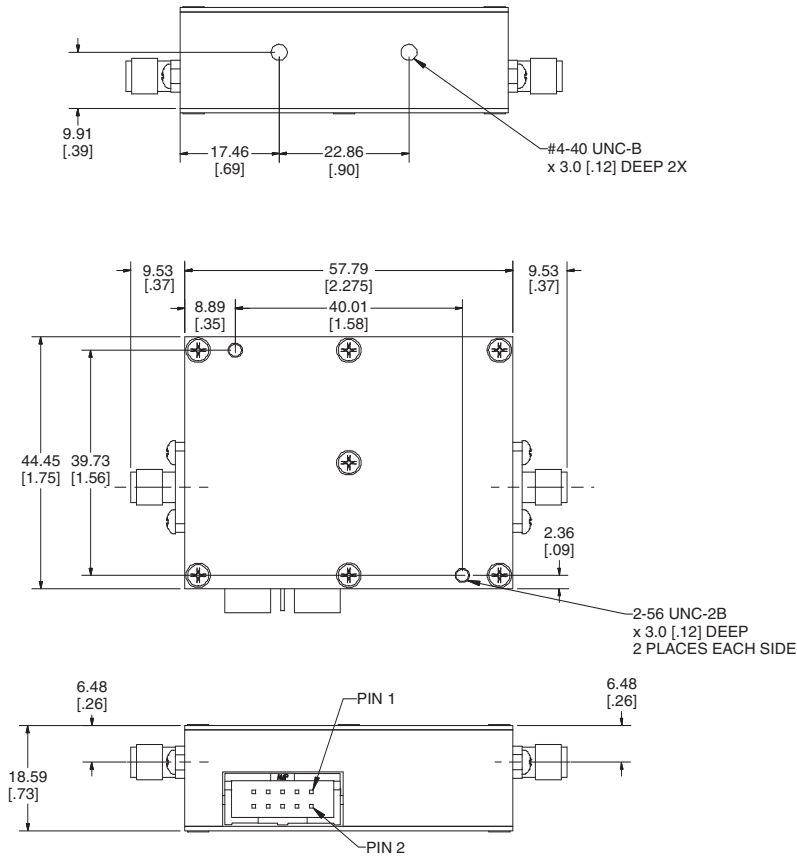

Control Connector J3 Pin Locations:

TTL Conn PIN No. (J3)	Designation
1	1.0
2	2.0
3	4.0
4	8.0
5	16.0
6	32.0
7	NC
8	NC
9	+5V
10	COM

NC = Not Connected

NOTE: All dimensions are given in mm (inches) and are maximum, unless otherwise specified.

Programmable Attenuators



Model 4203 Digital Attenuator with Built-in TTL Driver

0.2 to 3 GHz



Features

- /// Ideal for Automated Test Equipment (ATE), WiMAX, 3G Fading Simulators, Engineering/Production Test Lab environments
- /// Excellent Repeatability & Performance
- /// Custom Configurations Available Upon Request
- /// Ruggedized Construction

Description

Aeroflex / Weinschel's new line of MMIC Digital Attenuator operates over the 0.2 to 3 GHz frequency range and is in a variety of attenuation ranges.

Specifications

NOMINAL IMPEDANCE: 50 Ω
FREQUENCY RANGE: 0.2 to 3.0 GHz

CELL CONFIGURATIONS:		
Model Number	Attenuation Range/Steps (dB)	Attenuation Increments (dB)
4203-31.75	0 -31.75 / 0.25	0.25, 0.5, 1, 2, 4, 8, 16
4203-63	0-63 / 1	1, 2, 4, 8, 16, 32

ATTENUATION ACCURACY:								
CELL	0.25	0.50	1	2	4	8	16	32
dB	± 0.15	± 0.15	± 0.2	± 0.2	± 0.3	± 0.4	± 0.6	± 1.2

MAXIMUM INSERTION LOSS (dB):		
Frequency (GHz)	4203-31.75	4203-63
0.2 - 3.0	4.5	4.0

MAXIMUM SWR: 1.4:1
POWER RATING: +24 dBm maximum
SWITCHING SPEED: 1 μ Sec maximum
CONTROL LOGIC: TTL
OPERATING VOLTAGE: +5 V @ 20 mA
TEMPERATURE RANGE: 0°C to +70°C
TEST DATA: Test data can be provided at additional cost.
CONNECTORS: SMA female connector - mates non-destructively with other SMA connector per MIL-C-39012, 3.5mm and other 2.92mm connector.
CONTROL CONNECTOR: AMP-Latch 10 pin ribbon cable connector mates with AMP P/N 746285-1 (supplied with each unit)
CONTROL CONFIGURATION: Units are supplied with a built-in TTL interface. Each unit is supplied with a mating 10 pin connector (Amp 746285-1). Refer to Physical Dimensions for mating connector pin/wiring details. Two wires are specified for supply voltage and ground. The remaining wires will accept TTL control signals to activate or de-activate a particular attenuation cell. A TTL high will energize a cell to the high attenuation state, whereas a TTL low will maintain a cell in its zero attenuation state.
WEIGHT: 83 g (2.92 oz)

PHYSICAL DIMENSIONS:

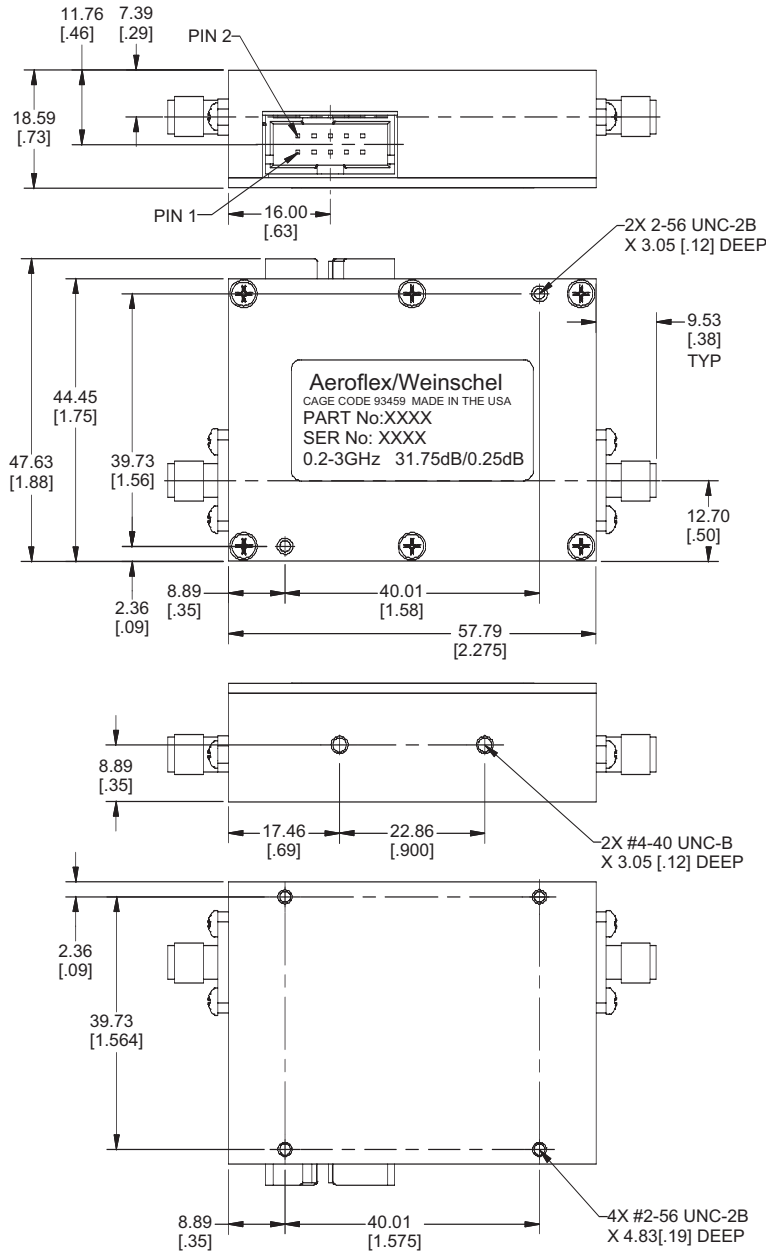

Control Connector J3 Pin Locations:

TTL Conn PIN No. (J3)	4203-31.75 dB (Cell)	4203-63 dB (Cell)
1	0.25	1.0
2	0.5	2.0
3	1.0	4.0
4	2.0	8.0
5	4.0	16.0
6	8.0	32.0
7	16.0	NC
8	NC	NC
9	+5V	+5V
10	GND	GND

NC = Not Connected

NOTE: All dimensions are given in mm (inches) and are maximum, unless otherwise specified.

Programmable Attenuators



Model 4205 Digital Attenuator TTL & USB Control, SMA Connectors

0.2 to 6 GHz

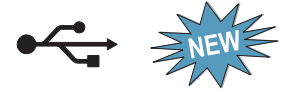

RoHS



Features

- /// Ideal for Automated Test Equipment (ATE), WiMAX, LTE, WiFi, 3G/4G Fading Simulators, Engineering/ Production Test Lab environments
- /// Excellent Solid-state Repeatability & Performance
- /// Uninterrupted RF when changing attenuation values
- /// Ruggedized Construction

Description

Aeroflex / Weinschel's New series of MMIC Digital Attenuators operates over the 0.2 to 6 GHz frequency range and is in a variety of attenuation ranges up to 95.5 dB in 0.5 dB steps. These units can be controlled using either parallel TTL or USB interfaces.

Specifications

NOMINAL IMPEDANCE: 50 Ω
FREQUENCY RANGE: 0.2 to 6.0 GHz

CELL CONFIGURATIONS:

Model Number	Attenuation Range/Steps (dB)	Attenuation Increments (dB)
4205-31.5	0 -31.5 / 0.5	0.5, 1, 2, 4, 8, 16
4205-63.5	0-63.5 / 0.5	0.5, 1, 2, 4, 8, 16, 32
4205-95.5	0-95.5 / 0.5	0.5, 1, 2, 4, 8, 16, 32, 32

ATTENUATION ACCURACY (dB):

dB range	4205-31.5	4205-63.5	4205-95.5
1 to 7.5 dB	± 0.5	± 0.5	± 0.5
8 to 11.5 dB	± 1.0	± 1.0	± 1.0
12 to 31.5	± 1.25	± 1.25	± 1.25 or 4%
32 to 63.5	---	± 1.25	± 1.25 or 4%
64 to 85 dB	---	---	± 1.25 or 4%
86 to 95 dB	---	---	$\pm 5\%$

MAXIMUM INSERTION LOSS (dB):

Frequency (GHz)	4205-31.5	4205-63.5	4205-95.5
0.2 - 3.0	3.0	4.5	6.5
3.0 - 6.0	4.0	6.0	8.0

MAXIMUM SWR:

Frequency (GHz)	4205-31.5	4205-63.5	4205-95.5
0.2 - 0.8	1.50	1.80	2.00
0.8 - 5.0	1.50	1.50	1.60
5.0 - 6.0	1.70	1.50	1.90

POWER RATING: +23 dBm maximum
SWITCHING SPEED: 1 μ sec maximum
CONTROL LOGIC: TTL or USB
OPERATING VOLTAGE: +5 V @ 50 mA
TEMPERATURE RANGE: 0°C to +70°C

TEST DATA: Test data can be provided at additional cost.

CONNECTORS: SMA female connectors - mates nondestructively with other SMA connectors per MIL-C-39012, 3.5mm and other 2.92mm connectors.

CONTROL CONNECTOR: The TTL control connector is an AMP-Latch 10 pin ribbon cable connector that mates with AMP P/N 746285-1 (supplied with each unit). The USB is a 5-pin female series B mini socket and mates with most standard USB 5-pin male series B mini plug connectors.

WEIGHT: 83 g (2.92 oz)

Control Software Included



Aeroflex / Weinschel's Labview based USB Control Center Software (AUCCS) can also be used in the operation of this series of digital attenuators. The AUCCS will allow the user to setup, control and perform test and measurements using these digital attenuators over a standard USB 2.0 communication interface.

CONTROL CONFIGURATION:

Units are supplied with both parallel-TTL and USB 2.0 interfaces. The mode of operation is determined by the source of DC power to the unit. **NOTE:** Do not simultaneously connect DC power to the J4 TTL connector while the USB is connected.

USING TTL CONTROL: Each unit is supplied with a mating 10 pin connector (Amp 746285-1). Refer to Physical Dimensions for mating connector pin/wiring details. Two pins are specified for supply voltage and ground. The remaining pins will accept TTL control signals to activate or de-activate a particular attenuation cell. A TTL high will

energize a cell to the high attenuation state, whereas a TTL low will maintain a cell in its zero attenuation state.

USING USB CONFIGURATION: The USB interface is compatible with standard USB 2.0 interfaces. In USB mode, DC power to the attenuator is provided by the host USB connection. The attenuator operates as a USB CDC device and accepts simple ASCII text commands. This allows the unit to be controlled from any system capable of sending data via a standard COM port-style interface.

PHYSICAL DIMENSIONS:

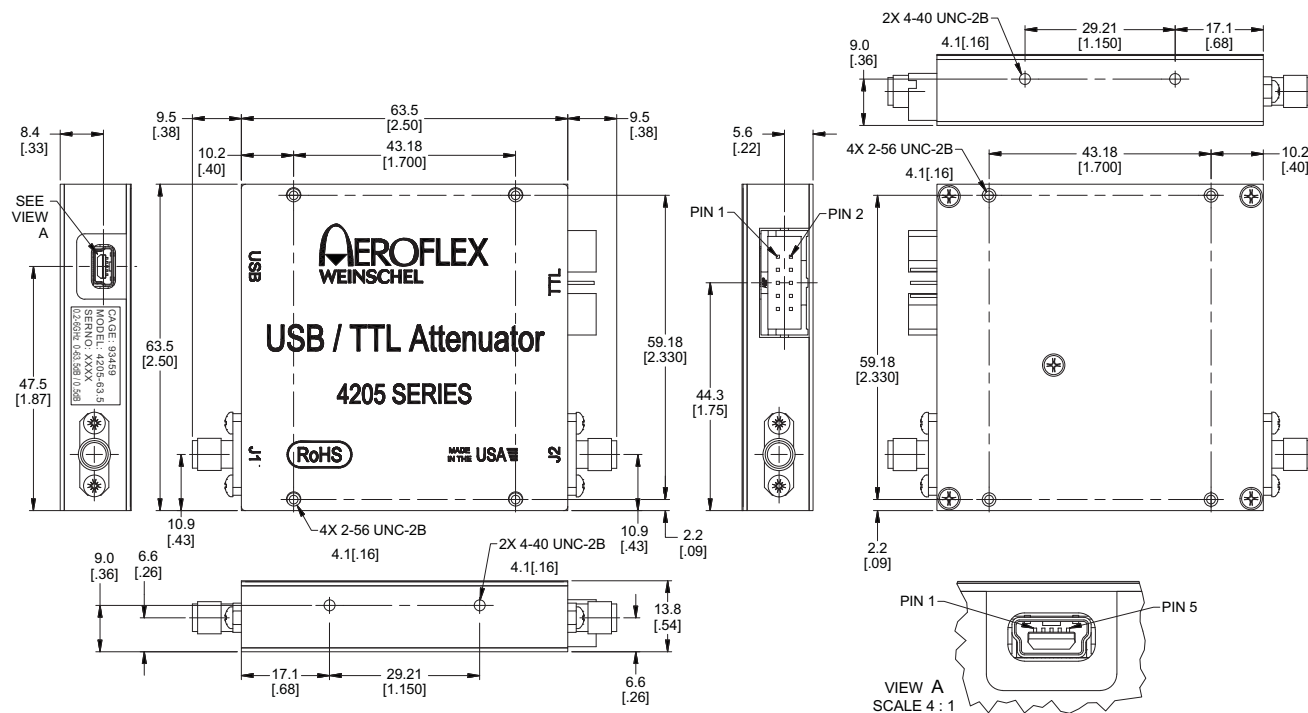

USB Control Connector J3 Pin Locations:

USB Conn PIN No. (J3)	Function
1	V BUS +5 V
2	Data-
3	Data+
4	ID (NC)
5	GND

TTL Control Connector J4 Pin Locations:

TTL Conn PIN No. (J3)	4205-31.5 dB (Cell)	4205-63.5 dB (Cell)	4205-95.5 dB (Cell)
1	0.5	0.5	0.5
2	1	1	1
3	2	2	2
4	4	4	4
5	8	8	8
6	16	16	16
7	NC	32	32
8	NC	NC	32
9	+5V	+5V	+5V
10	GND	GND	GND

NC = Not Connected.

NOTE: All dimensions are given in mm (inches) and are maximum, unless otherwise specified.

Programmable Attenuators



Models 4226 & 4228 Pin Switched Programmable Attenuators

0.8 to 2.5/3.0 GHz

Low Insertion Loss, Fast Switching

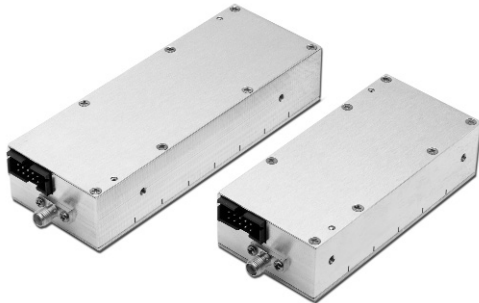

Features

Ideal for use in Wireless/Cellular, RF Simulation/Emulation, & Communication Test Applications.

- /// Available in 6 and 8 Cell Configurations -
 - 103 dB/1 dB steps
 - 63 dB/1 dB steps
 - 63.75/0.25 dB steps
- /// High accuracy & fast switching speed
- /// Built-in TTL Driver Circuitry
- /// Special Configurations Available Upon Request.
 - Custom Cell/Step Size & Frequency Bands

Specifications

NOMINAL IMPEDANCE: 50 Ω
FREQUENCY RANGE: 4226-63: 0.8 to 3.0 GHz
 4228-63.75: 0.8 to 2.5 GHz
 4228-103: 0.8 to 3.0 GHz

MAXIMUM SWR:	
Frequency Range (GHz)	SWR
0.8 - 3.0 (2.5)	1.50

CELL CONFIGURATIONS:			
Model Number	NO. Cells	Attenuation Range/Steps (dB)	Cell Increments (dB)
4228-103	8	103/1	1, 2, 4, 8, 16, 24, 48
4228-63.75	8	63.75/0.25	0.25, 0.5, 1, 2, 4, 8, 16, 32
4226-63	6	63/1	1, 2, 4, 8, 16, 32

INCREMENTAL ATTENUATION ACCURACY:										
CELL	0.25	0.50	1	2	4	8	16	24	32	48
dB	±0.1	±0.15	±0.2	±0.2	±0.2	±0.2	±0.3	±0.4	±0.6	±0.8

MAXIMUM INSERTION LOSS (dB):			
Frequency (GHz)	4226-63	4228-63.75	4228-103
0.8 - 3.0 (2.5)	3.75	4.50	5.50

MONOTONICITY: 4226-63 & 4228-103: 0.8 to 3.0 GHz
 4228-63.75: 0.8 to 2.5 GHz (minimum 1 dB change)

3rd ORDER INTERMODULATION (IM3): -55 dBm typical, measured with two +10 dBm tones @ 869 MHz (f1) and 891 MHz (f2), the IM3 frequency being 847 MHz (2f1-f2).

$$IP3 \text{ (input)} = +41 \text{ dBm}$$

The input IP3 is derived from the following relationship:

$$IP3 = \frac{3(P_{in-\alpha}) - IM3 + \alpha}{2}$$

where α = the insertion loss (dB) at the IM3 frequency;
 Pin=single tone input power (dBm).

POWER RATING: +24 dBm operating
 +30 dBm (1 dB compression point)

SWITCHING TIME: 2 μsec. maximum

OPERATING VOLTAGE: +5 V ± 5% @ 160 mA for 6 cell/
 200 mA for 8 cell typical

TEMPERATURE RANGE (Operating): 0°C to +70°C

TEMPERATURE COEFFICIENT: < 0.002 dB/dB/°C

CONNECTORS: SMA female connectors - mate nondestructively with MIL-C-39012 connectors.

CONTROL CONNECTOR: AMP-Latch 10 pin ribbon cable connector mates with AMP P/N 746285-1 (supplied with each unit)

WEIGHT: 4226-X 160 g (5.7 oz)
 4228-X 210 g (7.4 oz)

CONTROL CONFIGURATION: Units are supplied with a built-in TTL interface. Each unit is supplied with a mating 10 pin connector (Amp 746285-1). Refer to Physical Dimensions for mating connector pin/wiring details. Two wires are specified for supply voltage and ground. The remaining wires will accept TTL control signals to activate or de-activate a particular attenuation cell. A TTL high will energize a cell to the high attenuation state, whereas a TTL low will maintain a cell in its zero attenuation state.

DRIVER SPECIFICATIONS:

		minimum	maximum
V _{IH}	Input High Level	2.0 V	5.3 V
V _{IL}	Input Low Level	-0.3 V	0.8 V
I _{PU}	Input Pull-up Current	500 μA Typical	

Note: Inputs have 10K pull-up resistors.

PHYSICAL DIMENSIONS:

Models 4226 & 4228:

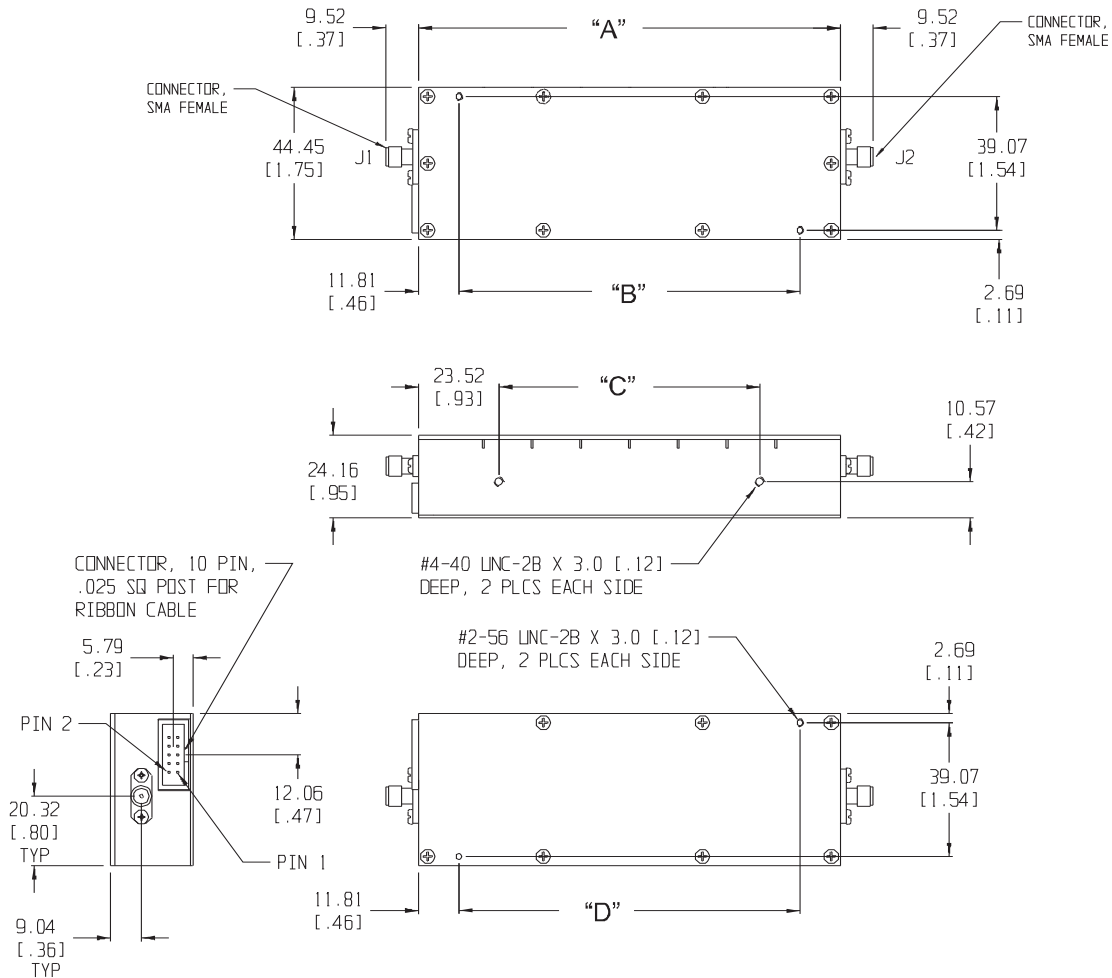

Model No.	A	B	C	D
4226-X	94.79 (3.73)	71.15 (2.80)	76.20 (3.00)	71.15 (2.80)
4228-X	123.24 (4.85)	99.59 (4.85)	76.20 (3.00)	99.59 (4.85)

NOTE:

- All dimensions are given in mm (inches) and are maximum, unless otherwise specified.
- Unit available with RoHS compliant materials, specify when ordering.

Control Connector J3 Pin Locations:

TTL Conn PIN No. (J3)	4226-63 dB (Cell)	4228-63.75 dB (Cell)	4228-103 dB (Cell)
1	1	0.25	1
2	2	0.50	2
3	4	1	4
4	8	2	8
5	16	4	16
6	32	8	24
7	NC	16	48
8	NC	32	NC*
9	+5V	+5V	+5V
10	COM	COM	COM

NC = Not Connected

* For Factory use only.

Model 4238 GaAs Switched Programmable Attenuator

10 MHz to 2.5 GHz
1 Watt

Low Insertion Loss, High IP3



Features

Ideal for use in Wireless/Cellular, RF Simulation/Emulation, & Communication Test Applications.

- /// **Broadband Performance** - 10 MHz to 2.5 GHz usable dc to 10 MHz with reduced specifications
- /// **High IP3 and High Power Rating** - Utilizes MESFET Switching
- /// **Flexible DC Voltage (+5 to +15 V)**
- /// **Low DC Power Consumption** - Ideal for portable battery powered equipment.
- /// **Custom Configurations including bus controlled attenuator subsystems**

Specifications

NOMINAL IMPEDANCE: 50 Ω

FREQUENCY RANGE: 10 MHz to 2.5 GHz

MAXIMUM SWR:	
Frequency Range (GHz)	SWR
0.01 - 0.25	1.75
0.25 - 2.5	1.40

CELL CONFIGURATIONS:			
Model Number	NO. Cells	Attenuation Range/Steps (dB)	Cell Increments (dB)
4238-63.75	8	63.75/0.25	0.25, 0.5, 1, 2, 4, 8, 16, 32
4238-103	8	103/1	1, 2, 4, 8, 16, 24, 48

INCREMENTAL ATTENUATION ACCURACY:										
CELL	0.25	0.50	1	2	4	8	16	24	32	48
dB	±0.15	±0.15	±0.2	±0.2	±0.2	±0.2	±0.3	±0.4	±0.6	±0.8

MAXIMUM INSERTION LOSS (dB):	
Frequency Range (GHz)	4238-X
0.01 - 1.0	6.75
1.0 - 2.0	8.25
2.0 - 2.5	9.75

MONOTONICITY: 10 MHz to 2.5 GHz
(minimum 1 dB change)

3rd ORDER INTERMODULATION (IM3): -60 dBm typical, measured with two +27 dBm tones @ 869 MHz (f1) and 894 MHz (f2), the IM3 frequency being 847 MHz (2f1-f2).

$$IP3 \text{ (input)} = +65 \text{ dBm}$$

The input IP3 is derived from the following relationship:

$$IP3 = \frac{3(Pin-\alpha)-IM3}{2} + \alpha$$

where α = the insertion loss (dB) at the IM3 frequency;
Pin=single tone input power (dBm).

INPUT POWER RATING: +30 dBm

SWITCHING TIME: 5 μsec. maximum

OPERATING VOLTAGE: + 5 to +15 V

OPERATING CURRENT: 25 mA typical

TEMPERATURE RANGE (Operating): 0°C to +70°C

TEMPERATURE COEFFICIENT: <0.002/dB/dB/°C

CONNECTORS: SMA female connectors - mate nondestructively with MIL-C-39012 connectors.

CONTROL CONNECTOR: AMP-Latch 10 pin ribbon cable connector mates with AMP P/N 746285-1 (supplied with each unit)

WEIGHT: 4238-X 150 g (5.3 oz)

CONTROL CONFIGURATION: Units are supplied with a built-in TTL interface. Each unit is supplied with a mating 10 pin connector (Amp 746285-1). Refer to Physical Dimensions for mating connector pin/wiring details. Two wires are specified for supply voltage and ground. The remaining wires will accept TTL control signals to activate or de-activate a particular attenuation cell. A TTL high will energize a cell to the high attenuation state, whereas a TTL low will maintain a cell in its zero attenuation state.

PHYSICAL DIMENSIONS:

Model 4238:

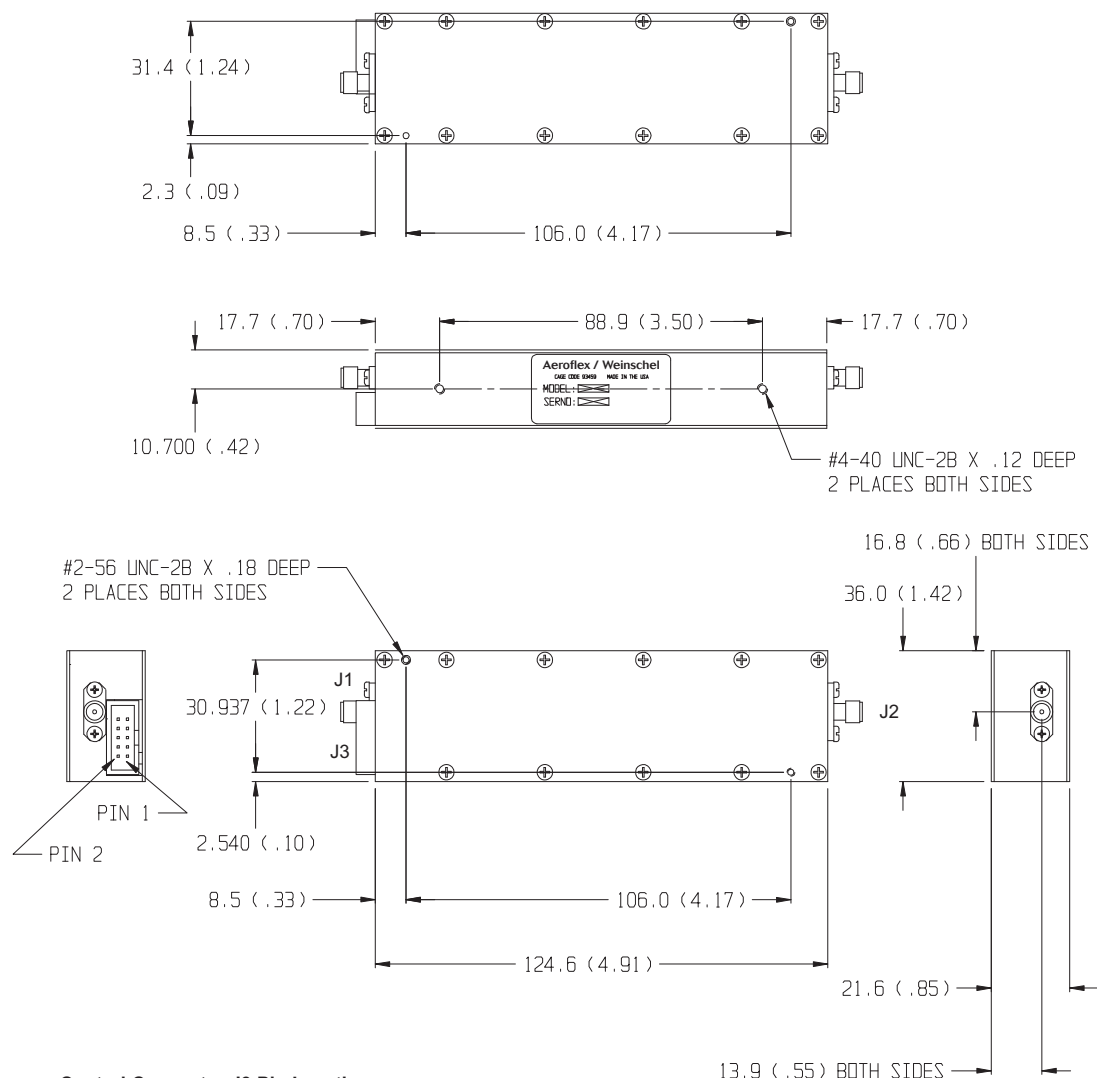

Control Connector J3 Pin Locations:

TTL Conn PIN No. (J3)	4238-103 dB (Cell)	4238-63.75 dB (Cell)
1	1	0.25
2	2	0.50
3	4	1
4	8	2
5	16	4
6	24	8
7	48	16
8	NC*	32
9	+5 to 15V	+5 to 15V
10	COM	COM

NC = Not Connected
* For Factory use only.

NOTE:

- All dimensions are given in mm (inches) and are maximum, unless otherwise specified.
- Unit available with RoHS compliant materials, specify when ordering.

Programmable Attenuators



Models 4246 & 4248 Phase Compensated GaAs Switched Programmable Attenuator

10 MHz to 2.5 GHz
4 Watts

Low Insertion Loss, High IP3



Features

Ideal for use in Wireless/Cellular, RF simulation/Emulation, & Communication Test Applications.

- /// **Broadband Performance** - 10 MHz to 2.5 GHz
- /// **High IP3 and High Power Rating**
- Utilizes MESFET Switching
- /// **Flexible DC Voltage (+5 to +15 V)**
- /// **Low DC Power Consumption** - Ideal for portable battery powered equipment.
- /// **Custom Configurations including bus controlled attenuator subsystems**

Specifications

NOMINAL IMPEDANCE: 50 Ω

FREQUENCY RANGE: 10 MHz to 2.5 GHz

MAXIMUM SWR:

Frequency Range	SWR
10 - 100 MHz	2.00
100 MHz - 200 MHz	1.60
200 MHz - 2.5 GHz	1.40

CELL CONFIGURATIONS:

Model Number	NO. Cells	Attenuation Range/Steps (dB)	Cell Increments (dB)
4246-63	6	63/1	1, 2, 4, 8, 16, 32
4248-63.75	8	63.75/0.25	0.25, 0.50, 1, 2, 4, 8, 16, 32
4248-103	8	103/1	1, 2, 4, 8, 16, 24, 48*

*48 dB cell comprised of two 24 dB cells

MAXIMUM INSERTION LOSS (dB):

Frequency Range	4246	4248
10 MHz - 1 GHz	8.0	10.5
1 - 2 GHz	9.0	12.0
2 - 2.5 GHz	10.0	13.0

INCREMENTAL ATTENUATION ACCURACY:

CELL	0.25	0.50	1	2	4	8	16	24	32	48
dB	±0.15	±0.15	±0.2	±0.2	±0.2	±0.2	±0.3	±0.4	±0.6	±0.8

MONOTONICITY: 10 MHz to 2.5 GHz
(minimum 1 dB change)

3rd ORDER INTERMODULATION (IM3): -43 dBm typical, measured with two +27 dBm tones @ 869 MHz (f1) and 894 MHz (f2), the IM3 frequency being 844 MHz (2f1-f2).

$$IP3 (\text{input}) = +58 \text{ dBm}$$

The input IP3 is derived from the following relationship:

$$IP3 = \frac{3(P_{in-\alpha}) - IM3}{2} + \alpha$$

where α = the insertion loss (dB) at the IM3 frequency;
Pin=single tone input power (dBm).

POWER RATING: 4 Watts maximum

SWITCHING TIME: 5 μsec. maximum

OPERATING VOLTAGE: + 5 V to +15V

OPERATING CURRENT: 25 mA typical

INCREMENTAL RELATIVE PHASE:

±5° between 0 and .25, 1, 2, 4, 8, 16 dB

±10° between 0 and 32, 48 dB

TEMPERATURE RANGE (Operating): 0°C to +70°C

TEMPERATURE COEFFICIENT: <0.002/dB/dB/°C

CONNECTORS: SMA female connectors - mate non-destructively with MIL-C-39012 connectors.

CONTROL CONNECTOR: AMP-Latch 10 pin ribbon cable connector mates with AMP P/N 746285-1 (supplied with each unit)

CONSTRUCTION:

Housing: Aluminum

Connectors: Stainless steel body and beryllium copper contacts.

WEIGHT: Model 4246: 227 g (8.0 oz)

Model 4248: 300 g (10.6 oz)

PHYSICAL DIMENSIONS:

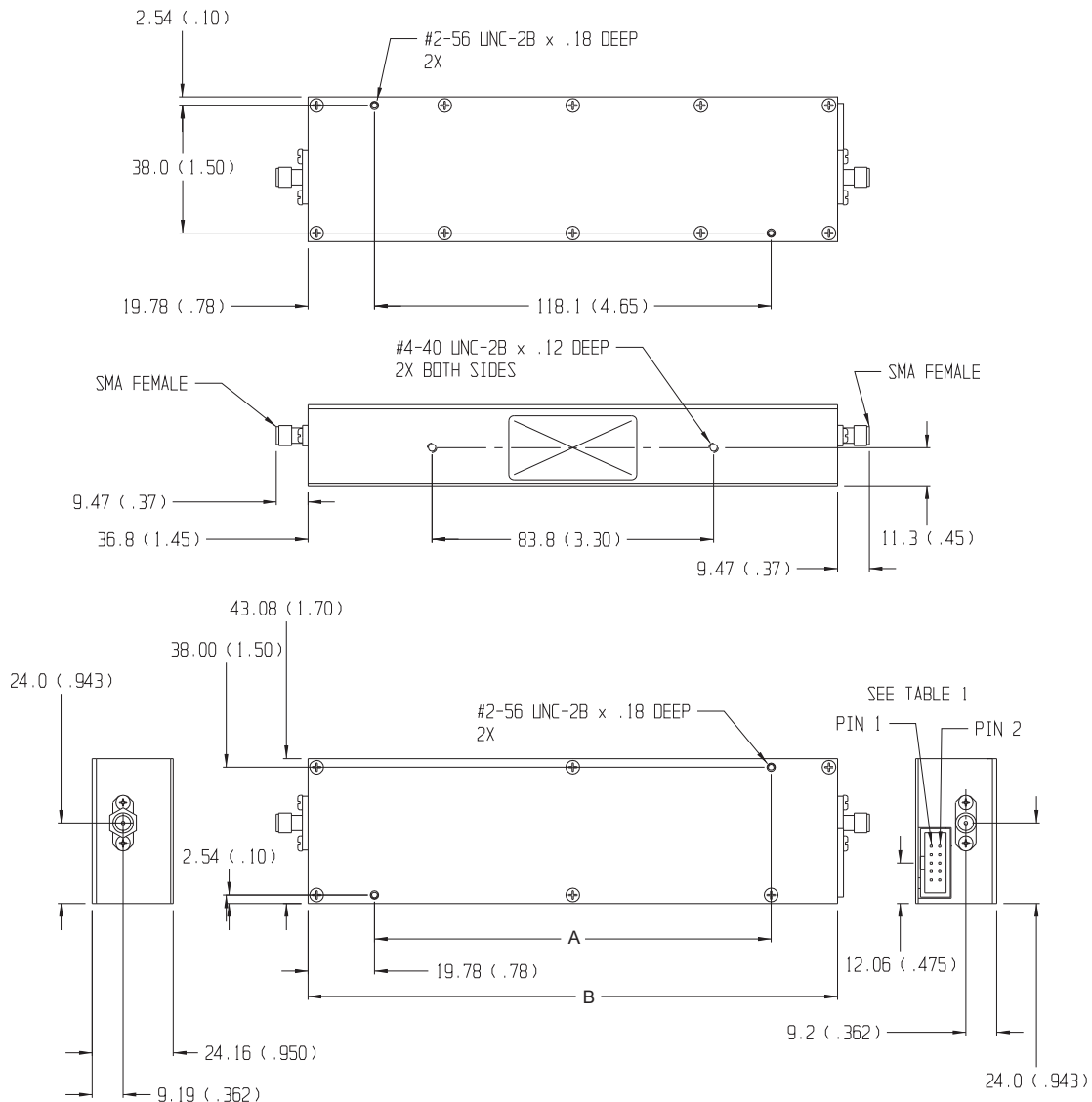

Control Connector J3 Pin Locations:

TTL Conn PIN No. (J3)	4238-63 dB (Cell)	4240-63.75 dB (Cell)	4240-103 dB (Cell)
1	1	0.25	1
2	2	0.50	2
3	4	1	4
4	16	2	8
5	32	4	16
6	8	8	24
7	NC	16	48
8	NC*	32	NC*
9	+5 Vdc	+5 Vdc	+5 Vdc
10	COM	COM	COM

NC = Not Connected
* For Factory use only.

Model No.	A	B
4246-X	82.50 (3.25)	122.50 (4.81)
4248-X	118.10 (4.65)	157.7 (6.21)

NOTE:

- All dimensions are given in mm (inches) and are maximum, unless otherwise specified.
- Unit available with RoHS compliant materials, specify when ordering.

CONTROL CONFIGURATION: Units are supplied with a built-in TTL interface. Each unit is supplied with a mating 10 pin connector (Amp 746285-1). Refer to Physical Dimensions for mating connector pin/wiring details. Two wires are specified for supply voltage and ground. The remaining wires will accept TTL control signals to activate or de-activate a particular attenuation cell. A TTL high will energize a cell to the high attenuation state, whereas a TTL low will maintain a cell in its zero attenuation state.

Programmable Attenuators



Model 4258

Digitally Controlled Variable PIN Attenuator with Built-in TTL Driver

2 to 6 GHz



Features

- /// Low Cost Design Solution
- /// Excellent Repeatability & Performance
- /// Custom Configurations Available Upon Request
- /// Highly Accurate Stepping
- /// Ruggedized Construction

Description

This new digitally controlled PIN diode attenuator provides excellent performance in the frequency range of 2-6 GHz. Attenuation levels up to 63.75 dB are programmable in increments of 0.25 dB while maintaining continuous signal. Each unit has an integrated driver consisting of an EEPROM, D/A and V/I converter with stable attenuation from 0 to +70 °C.

Physical Dimensions

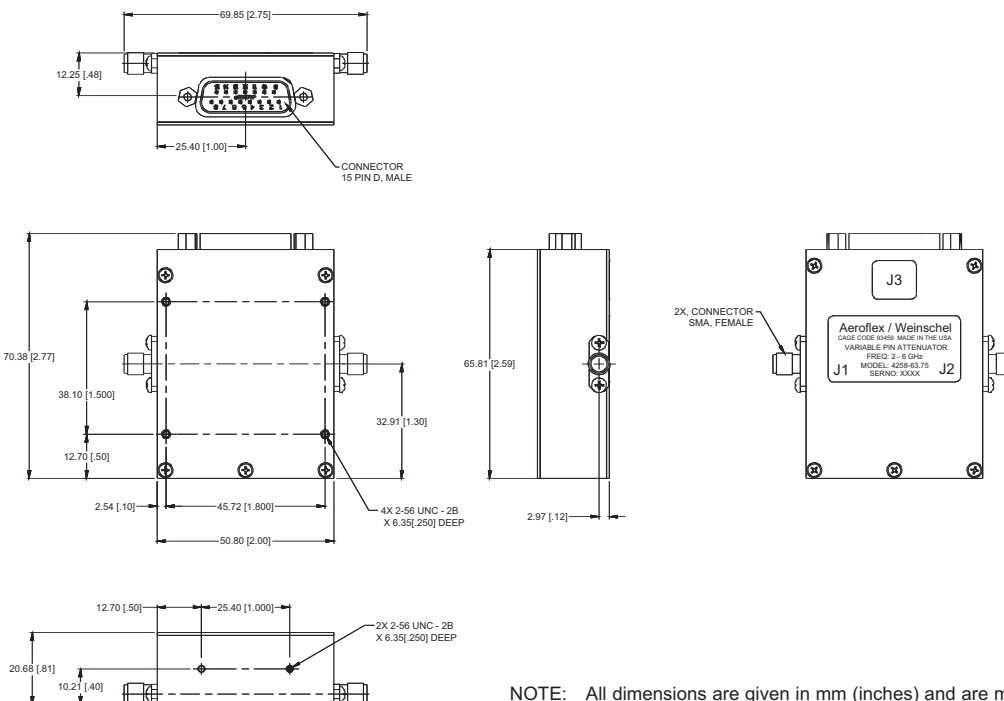

Specifications

- NOMINAL IMPEDANCE:** 50 Ω
- FREQUENCY RANGE:** 2.0 to 6.0 GHz
- ATTENUATION RANGE/STEPS:** 0-63.75 in 0.25 dB steps
- ATTENUATION FLATNESS:** ±2 dB maximum
- INSERTION LOSS:** 4.5 dB maximum
- MAXIMUM SWR:** 2.0:1
- POWER RATING:** 20 dBm (100 mW) maximum
- SWITCHING SPEED:** 1 μsec maximum
- OPERATING VOLTAGE:** ±15 V @ 100 mA
- TEMPERATURE RANGE:** 0°C to +70°C
- TEST DATA:** Test data can be provided at additional cost.
- CONNECTORS:** SMA female connector - mates nondestructively with other SMA connector per MIL-C-39012, 3.5mm and other 2.92mm connector.
- CONTROL CONNECTOR:** 15 pin D-sub connector, mates with Cannon connector DA-15S or equivalent.
- WEIGHT:** 83 g (2.92 oz)

Control Connector J3 Pin Locations:

TTL Conn PIN No. (J3)	Designation
1	0.25
2	0.50
3	1.0
4	2.0
5	4.0
6	8.0
7	16.0
8	32.0
9	NC
10	NC
11	NC
12	NC
13	+15V
14	-15V
15	GND

NC = Not Connected

NOTE: All dimensions are given in mm (inches) and are maximum, unless otherwise specified.

Models 8310 & 8311 Programmable Attenuator Units



RS232\RS422\RS485



Now Available with Ethernet Control!



Features

- /// Provides a flexible, easy to program, low cost solution for your bench test/calibration setups and subsystem applications.
- /// Multi-Channel attenuation paths (up to 4 input/outputs for 8310 & up to 6 input/outputs for 8311)
- /// Relative vs. Nominal attenuation step function.
- /// Wide choice of Frequency & Attenuation Ranges.
 - dc to 1, 2, 3, 6 & 18 GHz
 - NEW dc to 6 GHz Models
 - up to 127 dB
 - Solid-State (GaAs FET * & PIN)
 - Relay Switched
- /// Models with Ethernet Option - Specify when ordering.
- /// Accuracy & Repeatability.
- /// Designed to interface with Aeroflex / Weinschel's line of digitally controlled programmable attenuators and other electromechanical devices.
- /// Designed to interface with industry standard communication interfaces:
 - GPIB/IEEE-488 (HS-488 ready)
 - RS-232, RS-422, RS-485
 - New Models with Ethernet Control (10 BaseT)
- /// **Rack Configurable:** Model 8310 Series can be rack mounted either as a single unit using Rack Mounting Kit (P/N 193-8033-1) or two Model 8310's can be mounted together using Rack Mounting Kit (P/N 193-8033-2). These kits fit into any rack or cabinet that is designed per EIA RS-310 or MIL-STD-189. Rack ears are supplied with Model 8311 Series units.

Description

Aeroflex / Weinschel's 8310 and 8311 Series Programmable Attenuator Units represent a new concept in programmable attenuation for bench test and subsystem applications. Standard 8310 Series designs house and control various Aeroflex / Weinschel Programmable Attenuator Models (3200T, 150T, and 4200 Series) via front panel controls or standard communications interfaces including GPIB (IEEE-488), Ethernet and RS-232/RS-422/RS485. This series combines the features of the Aeroflex / Weinschel 8210A Device Controller with a front panel user interface to form a flexible, easy to use solution.

Most 8310 Series are single channel configurations where RF signal is routed through either the front or rear mounted Ports A & B but can be configured for up to four channels of attenuation, RF switching, amplification or other functions. Multiple programmable attenuators can be used in conjunction with other coaxial devices such as switches, power combiners, directional couplers, and filters creating single or multichannel subsystems.



Multi-Channel 19" Rack Size Versions

Applications

Applications for the 8310 and 8311 Series range from providing control of a single Programmable Attenuator in a bench test/lab environment using a PC and a terminal emulator, to complex system applications where the 8310/8311 Series are employed to control many devices to create custom/ semi-custom subsystems to reduce overall design cost. Aeroflex / Weinschel can provide a variety of custom designed driver interfaces for various devices, such as RF switches, relays, pin attenuators, motorized step attenuators, displays, and other devices, as well as complete subsystem design and integration services. Contact us with your specialized needs.

For additional information on the Model 8310, visit our website @ www.aeroflex.com/AW/8310.htm

Programmable Attenuators



Specifications

SPECIFICATION	DESCRIPTION
Input Power Requirements	ac 100 to 240 Vac, 50/60 Hz, 50 Watts
Environmental	Operating Temperature: 0 to +50°C Storage Temperature: 67° to +167 °F (-55° to +75°C) Humidity: 96% Altitude: 40,000' (12,192M)
IEEE-488 Bus (1)	Connector: 24-pin per IEEE-488.1 Protocols: per IEEE-488.2 Indicators: Remote (RMT), Listen (LSN), Talk (TLK), SRQ (SRQ)
RS-232 Bus (2) Serial I/O	Connector: 9-pin male D Signals: TXD, RXD, RTS, CTS, DTR, GND Baud Rates: 2400, 9600, 19200, and 38400 Data Bits: 8 Handshaking: None, RTS/CTS, XON/XOFF Parity: None, Odd, Even Indicators: Tx (Transmit) and Rx (Receive)
RS-422 BUS (3) RS-485 Bus (4)	Connector: 9-pin male D Signals: TXD+, TDX-, RXD+, RTX-, RTS+, RTS-, CTS+, CTS-, and signal GND Baud Rates: 2400, 9600, 19200, and 38400 Data Bits: 8 Handshaking: None, RTS/CTS, XON/XOFF Parity: None, Odd, Even Indicators: Tx (Transmit) and Rx (Receive)
Ethernet TC/IP	10 Base T Connector: Standard RJ45 Console Connector: 9-pin male D
RF Characteristics(5)	See ordering guides (pg 128 through 130)

1. GPIB/IEEE-488 model allows user-selectable addresses, Not included with Models with ethernet option.
2. RS-232 can be used with standard PC serial port for short and medium distances (up to approximately 50 ft).
3. RS-422, designed for very long distance communications (4000 ft) and optimized as a single node protocol, typically with one device connected to a single port.
4. RS-485, designed for very long distance communications (4000 ft) & optimized for multi-drop connections that can used to create a low cost network.
5. Refer to Individual data sheet for detailed specifications on internal programmables.

Ordering Guide...8310 Series with 4200 Programmables

Model No	Attenuation Value (dB)	Frequency Range (GHz)	Insertion Loss (maximum)	SWR (Maximum)	No of Channels	Attenuator Model No.*	Connector Type**	Conn Location
8310-136-F	63.75/0.25	0.8-2.5	6.0	1.6	1	4228-63.75	N/F	Front
8310-136-R	63.75/0.25	0.8-2.5	6.0	1.6	1	4228-63.75	N/F	Rear
8310-136-2-F	63.75/0.25	0.8-2.5	6.0	1.6	2	4228-63.75	N/F	Front
8310-136-2-R	63.75/0.25	0.8-2.5	6.0	1.6	2	4228-63.75	N/F	Rear
8310-137-F	63/1	0.8-3.0	4.7	1.6	1	4226-63	N/F	Front
8310-137-R	63/1	0.8-3.0	4.7	1.6	1	4226-63	N/F	Rear
8310-137-2-F	63/1	0.8-3.0	4.7	1.6	2	4226-63	N/F	Front
8310-137-2-R	63/1	0.8-3.0	4.7	1.6	2	4226-63	N/F	Rear
8310-138-F	103/1	0.8-3.0	6.0	1.6	1	4228-103	N/F	Front
8310-138-R	103/1	0.8-3.0	6.0	1.6	1	4228-103	N/F	Rear
8310-138-2-F	103/1	0.8-3.0	6.0	1.6	2	4228-103	N/F	Front
8310-138-2-R	103/1	0.8-3.0	6.0	1.6	2	4228-103	N/F	Rear
8310-138-3-T	103/1	0.8-3.0	6.0	1.6	3	4228-103	N/F	Front/Rear
8310-138-4-T	103/1	0.8-3.0	6.0	1.6	4	4228-103	N/F	Front/Rear

* Refer to Individual data sheet for detailed specifications on internal programmables.

** Add Suffix S to end of Model number for SMA connectors. Add N to the end of the Model number for ethernet option, IEEE-488 bus not included.

Ordering Guide...8310 Series with 3200 Programmables

Model No	Attenuation Value (dB)	Frequency Range (GHz)	Insertion Loss (maximum)	SWR (Maximum)	No of Channels	Attenuator Model No.*	Connector Type **	Conn Location
8310-35-F-E	127/1	dc-3.0	6.0 dB	1.4	1	3200T-1E	N/F	Front
8310-35-R-E	127/1	dc-3.0	6.0 dB	1.4	1	3200T-1E	N/F	Rear
8310-35-2-F-E	127/1	dc-3.0	6.0 dB	1.4	2	3200T-1E	N/F	Front
8310-35-2-R-E	127/1	dc-3.0	6.0 dB	1.4	2	3200T-1E	N/F	Rear
8310-35-3-T-E	127/1	dc-3.0	6.0 dB	1.4	3	3200T-1E	N/F	Front to Rear
8310-35-4-T-E	127/1	dc-3.0	6.0 dB	1.4	4	3200T-1E	N/F	Front to Rear
8310-36-F-E	64.5/0.1	dc-3.0	8.0 dB	1.4	1	3209T-1E	N/F	Front
8310-36-R-E	64.5/0.1	dc-3.0	8.0 dB	1.4	1	3209T-1E	N/F	Rear
8310-36-2-F-E	64.5/0.1	dc-3.0	8.0 dB	1.4	2	3209T-1E	N/F	Front
8310-36-2-R-E	64.5/0.1	dc-3.0	8.0 dB	1.4	2	3209T-1E	N/F	Rear
8310-36-3-T-E	64.5/0.1	dc-3.0	8.0 dB	1.4	3	3209T-1E	N/F	Front to Rear
8310-37-F-E	63.75/0.25	dc-3.0	6.0 dB	1.4	1	3200T-2E	N/F	Front
8310-37-R-E	63.75/0.25	dc-3.0	6.0 dB	1.4	1	3200T-2E	N/F	Rear
8310-37-2-F-E	63.75/0.25	dc-3.0	6.0 dB	1.4	2	3200T-2E	N/F	Front
8310-37-2-R-E	63.75/0.25	dc-3.0	6.0 dB	1.4	2	3200T-2E	N/F	Rear
8310-37-3-T-E	63.75/0.25	dc-3.0	6.0 dB	1.4	3	3200T-2E	N/F	Front to Rear
8310-37-4-T-E	63.75/0.25	dc-3.0	6.0 dB	1.4	4	3200T-2E	N/F	Front to Rear
8310-38-F-E	63/1	dc-3.0	5.25 dB	1.4	1	3206T-1E	N/F	Front
8310-38-R-E	63/1	dc-3.0	5.25 dB	1.4	1	3206T-1E	N/F	Rear
8310-38-2-F-E	63/1	dc-3.0	5.25 dB	1.4	2	3206T-1E	N/F	Front
8310-38-2-R-E	63/1	dc-3.0	5.25 dB	1.4	2	3206T-1E	N/F	Rear
8310-38-3-T-E	63/1	dc-3.0	5.25 dB	1.4	3	3206T-1E	N/F	Front to Rear
8310-38-4-T-E	63/1	dc-3.0	5.25 dB	1.4	4	3206T-1E	N/F	Front to Rear
8310-352-F	103/1	dc-6.0	6.00 dB	1.55	1	3408T-103	N/F	Front
8310-352-R	103/1	dc-6.0	6.00 dB	1.55	1	3408T-103	N/F	Rear
8310-352-2-F	103/1	dc-6.0	6.00 dB	1.55	2	3408T-103	N/F	Front
8310-352-2-R	103/1	dc-6.0	6.00 dB	1.55	2	3408T-103	N/F	Rear
8310-352-3-T	103/1	dc-6.0	6.00 dB	1.55	3	3408T-103	N/F	Front to Rear
8310-352-4-T	103/1	dc-6.0	6.00 dB	1.55	4	3408T-103	N/F	Front to Rear

Ordering Guide...8310 Series with 150 Programmables

Model No	Attenuation Value (dB)	Frequency Range (GHz)	Insertion Loss (maximum)	SWR (Maximum)	No of Channels	Attenuator Model No.*	Connector Type	Conn Location
8310-201-F	70/10	dc-18.0	3.25 dB	1.75	1	150T-70	SMA/F	Front
8310-201-R	70/10	dc-18.0	3.25 dB	1.75	1	150T-70	SMA/F	Rear
8310-201-2-F	70/10	dc-18.0	3.25 dB	1.75	2	150T-70	SMA/F	Front
8310-201-2-R	70/10	dc-18.0	3.25 dB	1.75	2	150T-70	SMA/F	Rear
8310-202-F	121/1	dc-18.0	5.25 dB	1.95	1	150T-11+150T-110	SMA/F	Front
8310-202-R	121/1	dc-18.0	5.25 dB	1.95	1	150T-11+150T-110	SMA/F	Rear
8310-204-F	62/2	dc-18.0	3.70 dB	1.95	1	150T-62	SMA/F	Front
8310-204-R	62/2	dc-18.0	3.70 dB	1.95	1	150T-62	SMA/F	Rear
8310-204-2-F	62/2	dc-18.0	3.70 dB	1.95	2	150T-62	SMA/F	Front
8310-204-2-R	62/2	dc-18.0	3.70 dB	1.95	2	150T-62	SMA/F	Rear

* Refer to Individual data sheet for detailed specifications on internal programmables.

** Add Suffix S to end of Model number for SMA connectors. Add N to the end of the Model number for ethernet option, IEEE-488 bus not included.

Programmable Attenuators



Ordering Guide...8311 Series!

Model No	Attenuation Value (dB)	Frequency Range (GHz)	Insertion Loss (maximum)	SWR (Maximum)	No of Channels	Attenuator Model No.*	Connector Type	Conn Location
8311-38-6-F-E	63/1	dc-2.0	5.25 dB	1.40	6	3206T-1E	N/F	Front
8311-38-12-T-E	63/1	dc-2.0	5.25 dB	1.40	12	3206T-1E	N/F	Front-Rear
8311-137-6-F	63/1	0.8-3.0	4.70 dB	1.60	6	4226-63	N/F	Front
8311-202-2-F	121/1	dc-18.0	5.25 dB	1.95	2	150T-11+150T-110	SMA/F	Front
8311-202-3-F	121/1	dc-18.0	5.25 dB	1.95	3	150T-11+150T-110	SMA/F	Front
8311-204-6-F	62/2	dc-18.0	3.70 dB	1.95	6	150T-62	SMA/F	Front
8311-352-6-F	103/1	dc-6.0	6.00 dB	1.55	6	3408T-103	SMA/F	Front
8311-352-9-T	103/1	dc-6.0	6.00 dB	1.55	9	3408T-103	SMA/F	Front-Rear

Physical Dimensions

8310 Series:

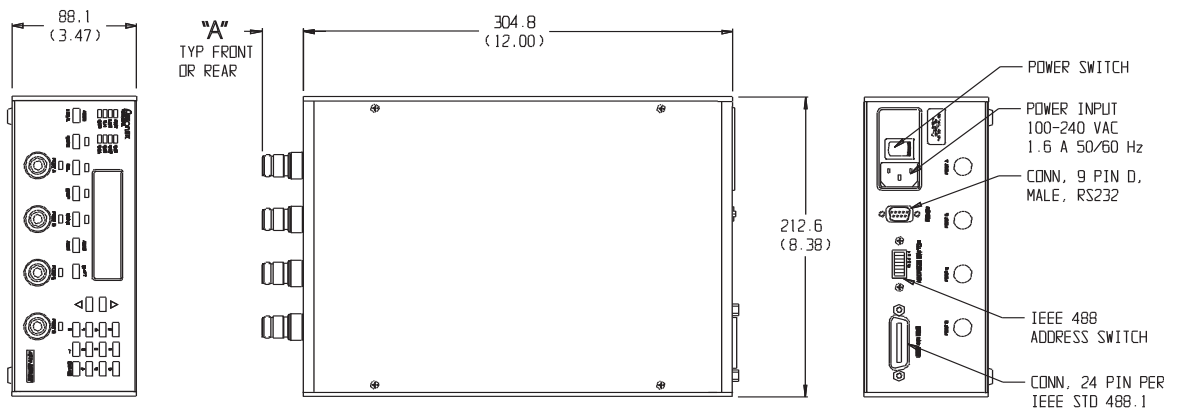

8311 Series:

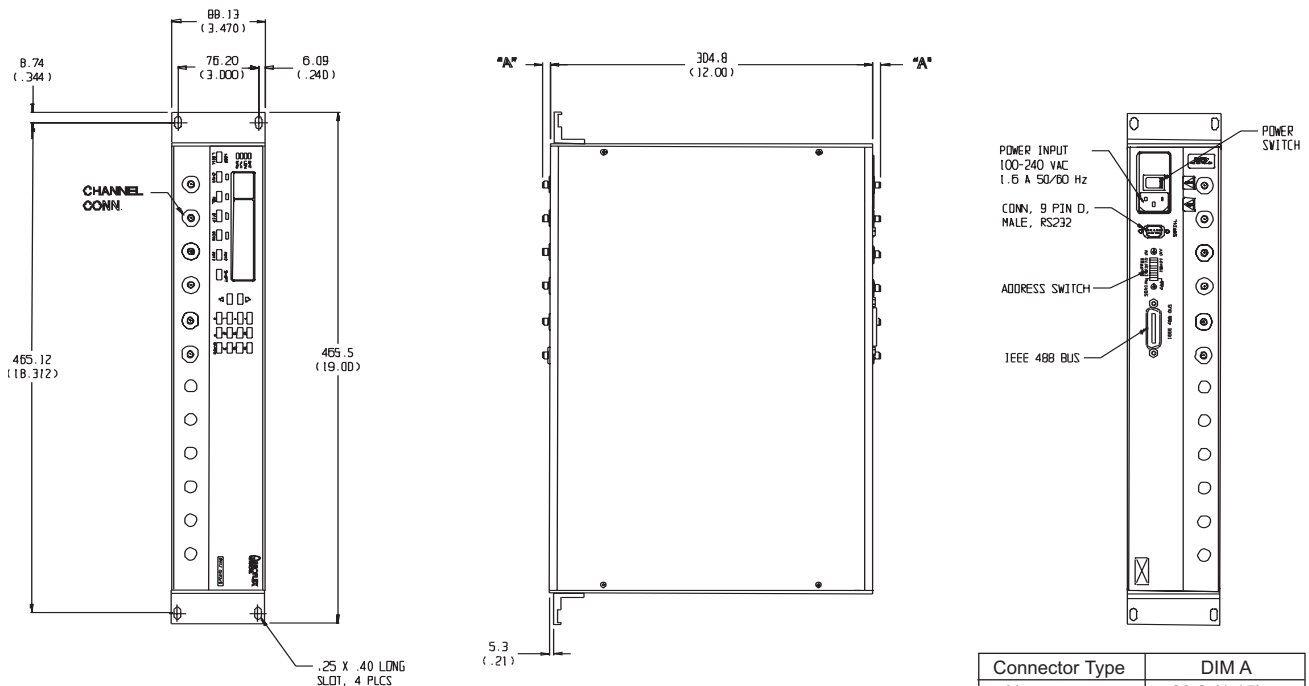

NOTE:

1. All dimensions are given in mm (inches) and are maximum, unless otherwise specified.
2. Connector location (Front/Rear) may vary depending on Model ordered.

Models 8320 & 8321 Programmable Attenuator Units Local, Ethernet, USB & RS-232 Control

up to 26.5 GHz



RoHS



Model 8321



Model 8320

Control Software Included



Aeroflex / Weinschel's Labview based Attenuator Control Center Software (ACCS) can be used in conjunction with the operation of the this series of programmable attenuator units and allows the user to setup, control and perform test and measurements over standard communication interfaces such as RS-232, USB, Ethernet or optional IEEE-488.

Features

- /// Provides a flexible, easy to program, low cost solution for your bench test/calibration setups and subsystem applications.
- /// Front panel local control and display make it ideal for lab and manual test environments.
- /// Relative vs. Nominal attenuation step function.
- /// Multi-Channel attenuation paths (up to 2 channels for 8320 & up to 12 channels for 8321)
- /// Relative vs. Nominal attenuation step function.
- /// Various Configurations, up to 26.5 GHz:
 - dc to 3, 6, 18 & 26.5 GHz
 - Attenuation ranges up to 127 dB
 - Solid-State (GaAs FET & PIN)
 - New MMIC switched digital attenuators
 - Relay Switched
- /// Accuracy & Repeatability.
- /// Designed to incorporate Aeroflex / Weinschel's line of digitally controlled programmable attenuators.
- /// Supplied with standard communication interfaces:
 - Ethernet (10/100 BaseT)
 - USB 2.0
 - RS-232 (Serial)
 - GPIB/IEEE-488 (HS-488 ready) optional
- /// Rack Configurable: Rack ears are supplied with Model 8321 Series units only.

Applications

Applications for the 8320 and 8321 Series range from providing control of a single Programmable Attenuator in a bench test/lab environment, to complex system applications where the 8320/8321 Series are employed inconjunction with many devices to create custom subsystems to reduce overall design cost. Multiple programmable attenuators can be used in conjunction with other coaxial devices such as switches, power combiners, directional couplers, and filters to create various multi-channel test configurations.

Description

Aeroflex / Weinschel's Model 8320 and 8321 Series Programmable Attenuator Units represent a new streamlined approach in programmable attenuation for bench test and subsystem applications. Standard 8320 and 8321 Series designs house and control various Aeroflex / Weinschel Programmable Attenuator Models (3200-XE, 3400, 150T, and 4200 Series) via front panel controls, ethernet, USB and Serial communications interfaces. A GPIB (IEEE-488) interface is also available as an option.

The 8320 series are single or dual channel configurations housed in half rack enclosures. The 8321 series are multi-channel configurations housed in 19 inch enclosures and can be configured for up to 12 attenuation channels. Both series can be configured for front or rear and through (front to rear) is only available for 8321 Series.

Aeroflex / Weinschel also provides custom subsystems where a variety of test configurations can be incorporated within a single unit. Contact us with your specialized needs.

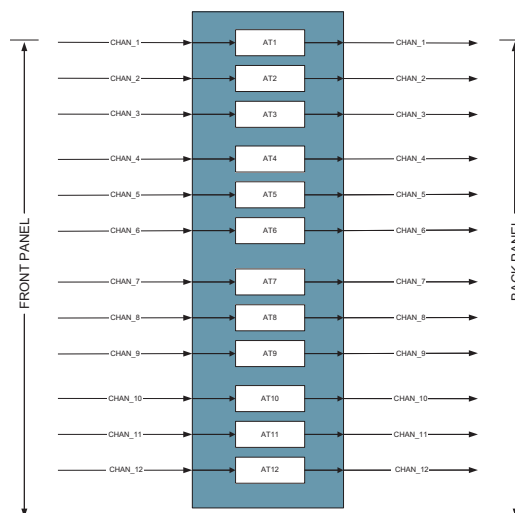

Simplified 12 Channel Block Diagram

For additional information on the Model 8320 & 8321, visit our website @ www.aeroflex.com/AW8320&8321

Specifications

SPECIFICATION	DESCRIPTION
Input Power Requirements	ac 100 to 240 Vac, 50/60 Hz, 180 Watts
Environmental	Operating Temperature: 0° to +50°C Storage Temperature: -67° to +167 °F (-55° to +75°C) Humidity: 96% (non-condensing) Altitude: 40,000' (12,192M)
RS-232 Bus (1) Serial I/O	Connector: 9-pin male D Signals: TXD, RXD, RTS, CTS, GND Baud Rates: 9600 to 230400 Data Bits: 8 Handshaking: None, RTS/CTS Parity: None
USB 2.0	Connector: Mini B
Ethernet	10/100 Base T Connector: Standard RJ45
IEEE-488 Bus (2) (GPIB option)	Connector: 24-pin per IEEE-488.1 Protocols: per IEEE-488.2
RF Characteristics(3)	Refer to Configuration Matrix (pg 3)

1. RS-232 can be used with standard PC serial port for short and medium distances (up to approximately 50 ft).
2. GPIB/IEEE-488 model allows user-selectable addresses. (Not included on standard models, must be ordered as an option).
3. Refer to Individual data sheet for detailed specifications on internal programmables.

Model Number Configuration Matrix

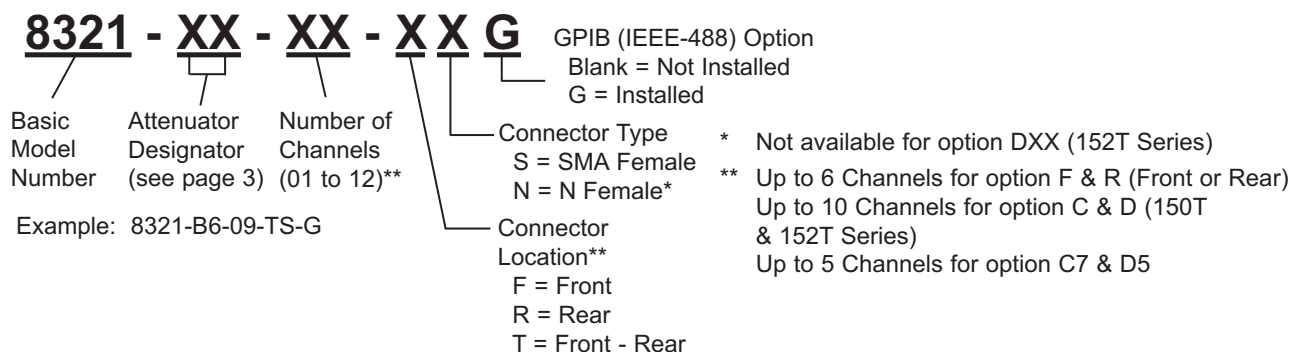
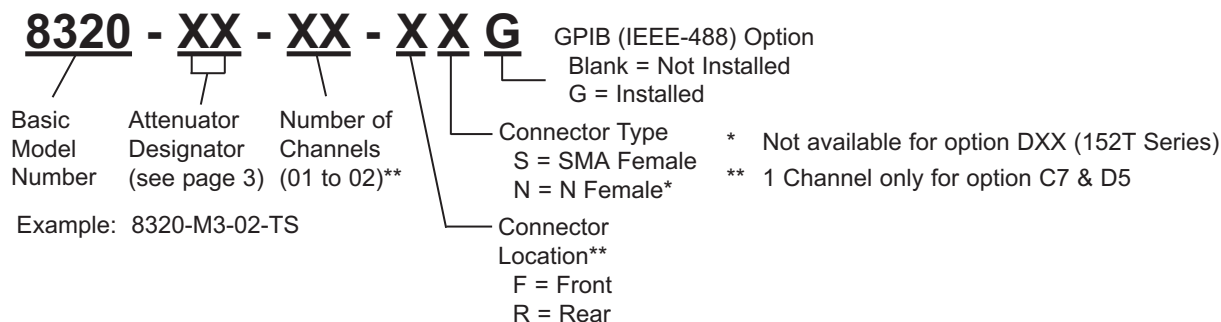

Electro-mechanical								
Frequency Range	Attenuator Designation	Attenuator Model	Range (dB)	Step Size (dB)	Insertion Loss (maximum)	VSWR (maximum)	<input checked="" type="checkbox"/> RoHs	
DC-3 GHz	A	1	3205-1E	70	10	3.75 dB	1.4	
		2	3205-2E	55	5	3.75 dB	1.4	
		3	3205-3E	1.5	0.1	3.75 dB	1.4	
		4	3201-1E	31	1	4.00 dB	1.4	
		5	3206-1E	63	1	4.25 dB	1.4	
		6	3200-1E	127	1	5.25 dB	1.4	
		7	3200-2E	63.75	0.25	5.25 dB	1.4	
		8	3209-1E	64.5	0.1	6.00 dB	1.4	
DC-6 GHz	B	1	3404-15	15	1	3.50 dB	1.55	
		2	3404-55	55	5	3.50 dB	1.55	
		3	3404-70	70	10	3.50 dB	1.55	
		4	3406-55	55	1	4.50 dB	1.55	
		5	3408-55.75	55.75	0.25	6.00 dB	1.55	
		6	3408-103	103	1	6.00 dB	1.55	
DC-18 GHz	C	1	150T-70	70	10	3.25 dB	1.75	✓
		2	150T-15	15	1	3.50 dB	1.95	✓
		3	150T-75	75	5	3.50 dB	1.95	✓
		4	150T-110	110	10	3.50 dB	1.95	✓
		5	150T-31	31	1	3.75 dB	1.95	✓
		6	150T-62	62	2	3.75 dB	1.95	✓
		7	150T-15 & 150T-110	125	1	5.25 dB	1.95	✓
DC-26.5 GHz	D	1	152AT-70	70	10	4.75 dB	1.95	✓
		2	152T-15	15	1	5.00 dB	1.95	✓
		3	152T-75	75	5	5.00 dB	1.95	✓
		4	152T-90	90	10	5.00 dB	1.95	✓
		5	152T-90 & 152T-15	105	1	6.50 dB	1.95	✓
Solid State								
0.8 to 2.5/3 GHz	J	1	4226-63	63	1	4.75 dB	1.6	
		2	4228-63.75	63.75	0.25	6.00 dB	1.6	
		3	4228-103	103	1	6.00 dB	1.6	
0.01 to 2.5 GHz	K	1	4238-63.75	63.75	0.25	10.00 dB	1.75	
		2	4238-103	103	1	10.00 dB	1.75	
0.01 to 2.5 GHz	L	1	4246-63	63	1	11.00 dB	2.0	
		2	4248-63.75	63.75	0.25	14.00 dB	2.0	
		3	4248-103	103	1	14.00 dB	2.0	
0.2 to 6 GHz	M	1	4205-31.5	31.5	0.5	4.00 dB	1.8	✓
		2	4205-63.5	63.5	0.5	6.00 dB	1.8	✓
		3	4205-95.5	95.5	0.5	8.50 dB	2.0	✓

RoHs compliance dependent on attenuator installed. Some attenuators are NOT compliant.

Programmable Attenuators



Physical Dimensions

Model 8320, Half Rack Unit, 1 or 2 channels:

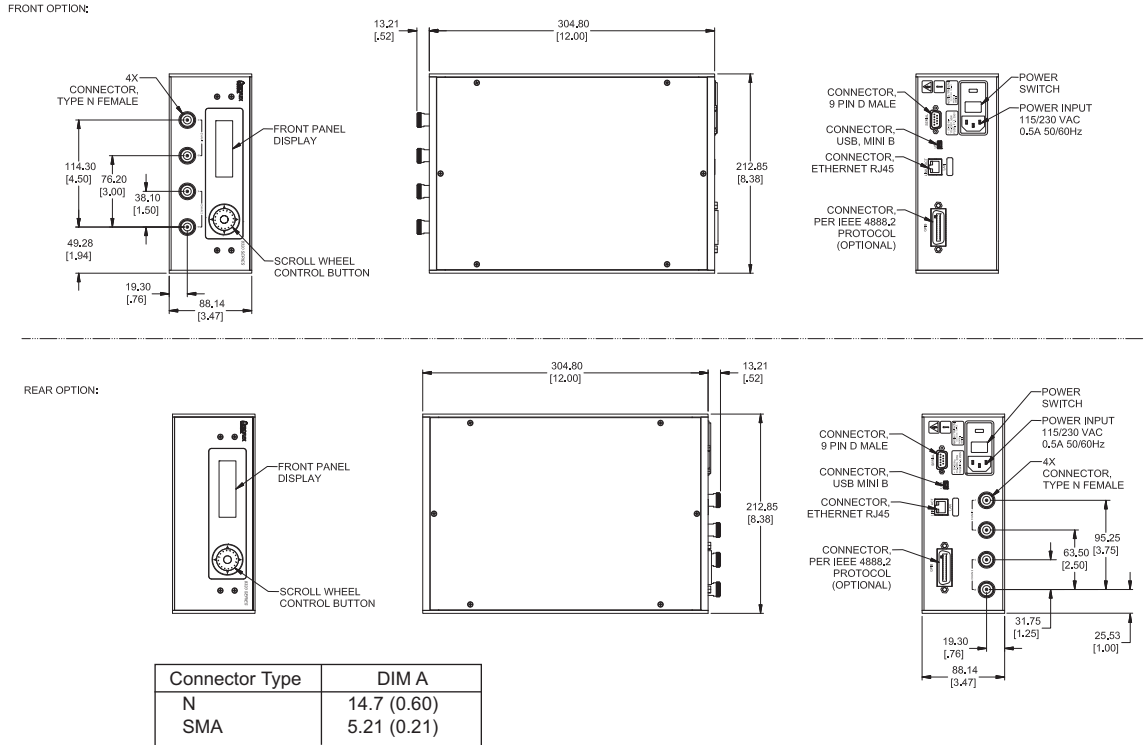

Model 8321, Standard 19 in Rack Unit up to 12 channels:

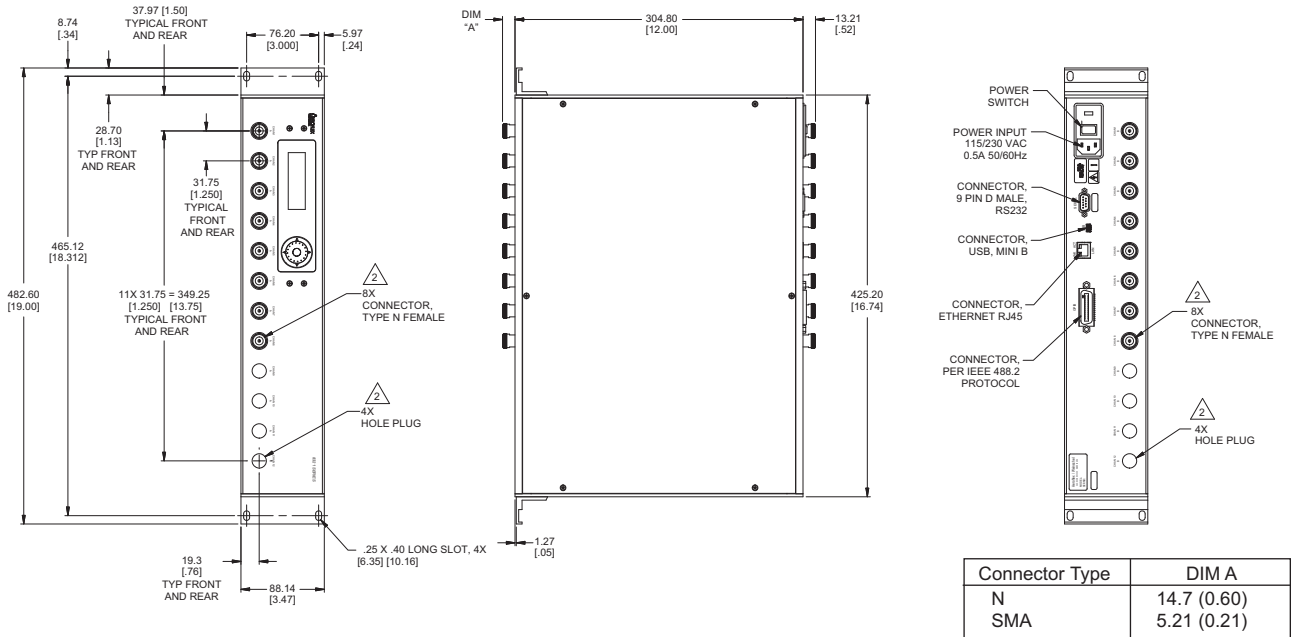

NOTE:

1. All dimensions are given in mm (inches).
2. Connectors and hole plugs are installed as required and determined by number of channel in unit. 2 channel shown for Model 8320 and 8 channel unit shown for 8321.
3. Connector location (Front/Rear) may vary depending on Model ordered.

Models 8331 Programmable Attenuator Unit Ethernet, USB & RS-232 Control

up to 26.5 GHz

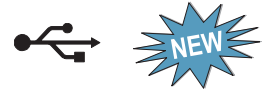

Features

- /// Provides a flexible, easy to program, low cost solution for your bench test/calibration setups and subsystem applications.
- /// Multi-Channel attenuation paths (up to 12 channels)
- /// Relative vs. Nominal attenuation step function.
- /// Various Configurations, up to 26.5 GHz:
 - dc to 3, 6, 18 & 26.5 GHz
 - up to 127 dB
 - Solid-State (GaAs FET & PIN)
 - New MMIC switched digital attenuators
 - Relay Switched
- /// Accuracy & Repeatability.
- /// Designed to incorporate Aeroflex / Weinschel's line of digitally controlled programmable attenuators.
- /// Designed to interface with industry standard communication interfaces:
 - RS-232 (Serial)
 - Ethernet (10/100 BaseT)
 - USB 2.0
- /// **Rack Configurable:** Rack ears are supplied with Model 8331 Series units.
- /// Ideal for Automated Test Equipment (ATE), WiMAX, 3G Fading Simulators, Engineering/Production Test Lab environments.

Applications

Designed with budget and performance concerns in mind, these devices offer superior RF characteristics suitable for automated bench testing in wireless backhaul, fading simulation, and other high performance wireless applications.

Control Software Included



Aeroflex / Weinschel's Labview based Attenuator Control Center Software (ACCS) can be used in conjunction with the operation of the this series of programmable attenuator units and allows the user to setup, control and perform test and measurements over standard communication interfaces such as RS-232, USB 2.0 or Ethernet.

Description

Aeroflex / Weinschel's New 8331 Series Programmable Attenuator Units offer a lower cost solution for automated bench test and subsystem applications. Standard 8331 Series designs house and control various Aeroflex / Weinschel Programmable Attenuator Models (3200-XE, 3400, 150T, and 4200 Series) via ethernet, USB 2.0 and Serial communications interfaces.

Most 8331 Series are multi-channel configurations where RF signal is routed through either the front or rear mounted Ports. This series can be configured for up to 12 independent channels of attenuation. Multiple programmable attenuators can be used in conjunction with other coaxial devices such as switches, power combiners, directional couplers, and filters creating various multichannel test configurations.

Aeroflex / Weinschel also provides custom subsystems where a variety of test configurations can be incorporated within a single unit. Contact us with your specialized needs.

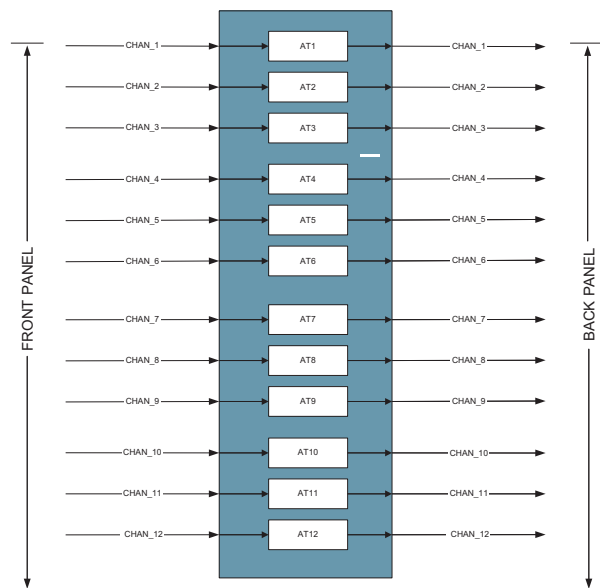

Simplified 12 Channel Block Diagram

For additional information on the Model 8331, visit our website @ www.aeroflex.com/AW8331

Programmable Attenuators



Specifications

SPECIFICATION	DESCRIPTION
Input Power Requirements	ac 100 to 240 Vac, 50/60 Hz, 180 Watts
Environmental	Operating Temperature: 0° to +50°C Storage Temperature: -67° to +167 °F (-55° to +75°C) Humidity: 96% (non-condensing) Altitude: 40,000' (12,192M)
RS-232 Bus (1) Serial I/O	Connector: 9-pin male D Signals: TXD, RXD, RTS, CTS, GND Baud Rates: 9600 to 230400 Data Bits: 8 Handshaking: None, RTS/CTS Parity: None
USB 2.0	Connector: Mini B
Ethernet	10/100 Base T Connector: Standard RJ45
RF Characteristics(2)	Refer to Configuration Matrix (pg 254)

- RS-232 can be used with standard PC serial port for short and medium distances (up to approximately 50 ft).
- Refer to Individual data sheet for detailed specifications on internal programmables.

Physical Dimensions

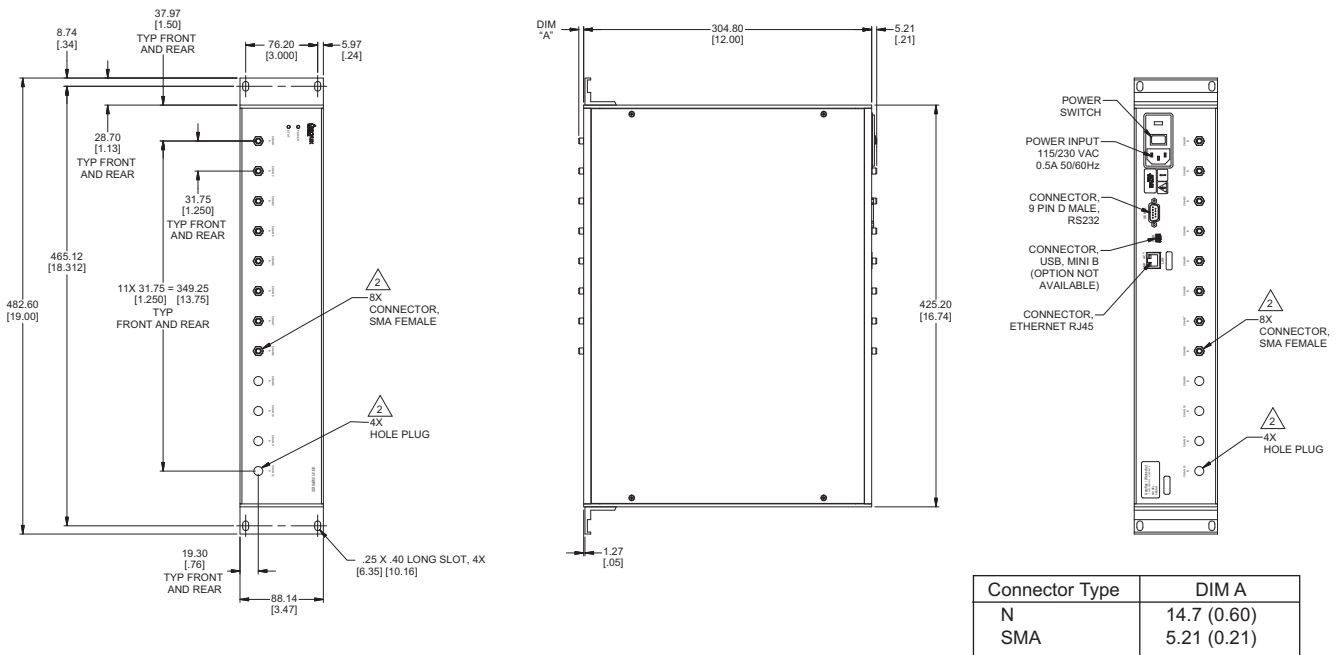

NOTE:

- All dimensions are given in mm (inches).
- Connectors and hole plugs are installed as required and determined by number of channel in unit. 8 channel unit shown
- Connector location (Front/Rear) may vary depending on Model ordered.

Model Number Configuration Matrix

8331 - XX - XX - XX

Basic Model Number
Attenuator Designator (see below)
Number of Channels (01 to 12)**

Example: 8331-M3-09-TS

Connector Type
S = SMA Female
N = N Female*

Connector Location**
F = Front
R = Rear
T = Front - Rear

* Not available for option DXX (152T Series)

** Up to 6 Channels for option F & R (Front or Rear)
Up to 10 Channels for option C & D (150T & 152T Series)
Up to 5 Channels for option C7 & D5

Electro-mechanical								
Frequency Range	Attenuator Designation	Attenuator Model	Range (dB)	Step Size (dB)	Insertion Loss (maximum)	VSWR (maximum)	<input checked="" type="checkbox"/> RoHs	
DC-3 GHz	A	1	3205-1E	70	10	3.75 dB	1.4	
		2	3205-2E	55	5	3.75 dB	1.4	
		3	3205-3E	1.5	0.1	3.75 dB	1.4	
		4	3201-1E	31	1	4.00 dB	1.4	
		5	3206-1E	63	1	4.25 dB	1.4	
		6	3200-1E	127	1	5.25 dB	1.4	
		7	3200-2E	63.75	0.25	5.25 dB	1.4	
		8	3209-1E	64.5	0.1	6.00 dB	1.4	
DC-6 GHz	B	1	3404-15	15	1	3.50 dB	1.55	
		2	3404-55	55	5	3.50 dB	1.55	
		3	3404-70	70	10	3.50 dB	1.55	
		4	3406-55	55	1	4.50 dB	1.55	
		5	3408-55.75	55.75	0.25	6.00 dB	1.55	
		6	3408-103	103	1	6.00 dB	1.55	
DC-18 GHz	C	1	150T-70	70	10	3.25 dB	1.75	✓
		2	150T-15	15	1	3.50 dB	1.95	✓
		3	150T-75	75	5	3.50 dB	1.95	✓
		4	150T-110	110	10	3.50 dB	1.95	✓
		5	150T-31	31	1	3.75 dB	1.95	✓
		6	150T-62	62	2	3.75 dB	1.95	✓
		7	150T-15 & 150T-110	125	1	5.25 dB	1.95	✓
DC-26.5 GHz	D	1	152AT-70	70	10	4.75 dB	1.95	✓
		2	152T-15	15	1	5.00 dB	1.95	✓
		3	152T-75	75	5	5.00 dB	1.95	✓
		4	152T-90	90	10	5.00 dB	1.95	✓
		5	152T-90 & 152T-15	105	1	6.50 dB	1.95	✓
Solid State								
0.8 to 2.5/3 GHz	J	1	4226-63	63	1	4.75 dB	1.6	
		2	4228-63.75	63.75	0.25	6.00 dB	1.6	
		3	4228-103	103	1	6.00 dB	1.6	
0.01 to 2.5 GHz	K	1	4238-63.75	63.75	0.25	10.00 dB	1.75	
		2	4238-103	103	1	10.00 dB	1.75	
0.01 to 2.5 GHz	L	1	4246-63	63	1	11.00 dB	2.0	
		2	4248-63.75	63.75	0.25	14.00 dB	2.0	
		3	4248-103	103	1	14.00 dB	2.0	
0.2 to 6 GHz	M	1	4205-31.5	31.5	0.5	4.00 dB	1.8	✓
		2	4205-63.5	63.5	0.5	6.00 dB	1.8	✓
		3	4205-95.5	95.5	0.5	8.50 dB	2.0	✓

RoHs compliance dependent on attenuator installed. Some attenuators are NOT compliant.

Model 8334
Attenuator Profile Simulator Unit
Ethernet, USB & RS232 Control

up to 6.0 GHz

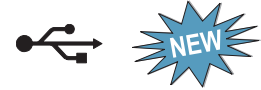

RoHS

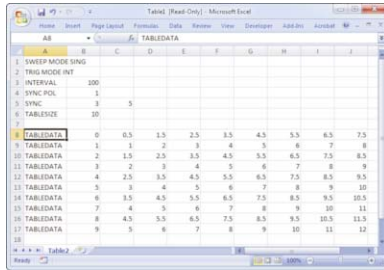

Features

- /// Programmable attenuation update rates from 100 μ sec per point to 1 sec per point in 100 μ sec intervals
- /// External TTL trigger (with programmable polarity) allows for synchronization with other external hardware
- /// Various TTL status outputs (Running, Programmable Sync, and Interval Update) for monitoring a profile
- /// Supplied with industry standard communication interfaces:
 - RS-232 (Serial)
 - Ethernet Control (10/100 BaseT)
 - USB 2.0
- /// Rack Configurable: Rack ears are supplied.

Description

Aeroflex / Weinschel's 8334 Series of Attenuation Profile Simulators provide multi-channel high-speed attenuation control with synchronous output update capability. The unit allows for programming of up to 128K (131072) attenuation data points per attenuator and sweeping through those data points at user-programmable intervals from 100us to 1sec per point. The system provides for non-volatile storage of up to four data point tables which may be later recalled under user control. Status and control TTL signals are available for external monitoring and sweep control via a rear-panel DE9 connector.

The 8334 Series are multi-channel configurations housed in 19 inch enclosures and can be configured for up to 8 attenuation channels. This series can be configured for front, rear or through (front to rear) RF signal routing.

Aeroflex / Weinschel also provides custom subsystems where a variety of test configurations can be incorporated within a single unit. Contact us with your specialized needs.

Applications

Applications for the 8334 Series include:

- /// Simulate path loss on each channel or mobility scenarios between a handset and multiple base stations
- /// Create arbitrary, synchronous attenuation profiles with timing skews of <10 nsec between channels to replicate precision fading and handover scenarios
- /// Generate coherent, multi-channel pulsed RF outputs for a given attenuation level

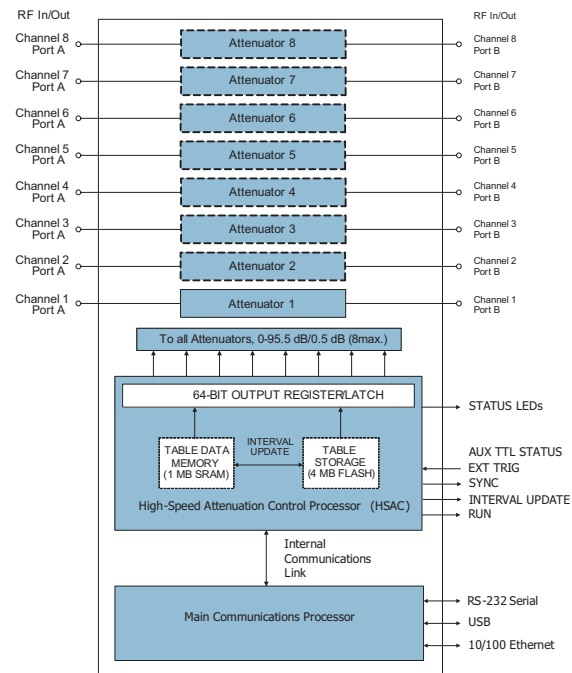

Simplified 8 Channel Block Diagram

For additional information on the Model 8334, visit our website @ www.aeroflex.com/AW8334

Specifications

SPECIFICATION	DESCRIPTION
Input Power Requirements	ac 100 to 240 Vac, 50/60 Hz, 180 Watts
Environmental	Operating Temperature: 0° to +50°C Storage Temperature: -40° to +167 °F (-40° to +75°C) Humidity: 96% (non-condensing) Altitude: 40,000' (12,192M)
RS-232 Bus (1) Serial I/O	Connector: 9-pin male D Signals: TXD, RXD, RTS, CTS, GND Baud Rates: 9600 to 230400 Data Bits: 8 Handshaking: None, RTS/CTS
AUX	Connector: 9-pin male D Signals: SYNC, EXT TRIG, INTERVAL UPDATE, RUN, GND
USB 2.0	Connector: Mini B
Ethernet	10/100 Base T Connector: Standard RJ45
RF Characteristics(3)	Refer to Configuration Matrix (below)

1. RS-232 can be used with standard PC serial port for short and medium distances (up to approximately 50 ft).
2. Refer to Individual data sheet for detailed specifications on internal programmables.

Model Number Configuration Matrix

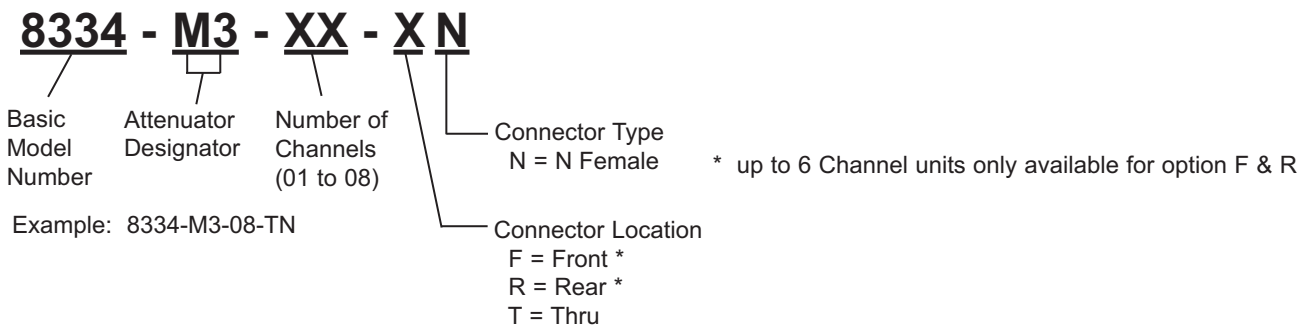

Solid State (Only)								
Frequency Range	Attenuator Designation		Attenuator Model	Range (dB)	Step Size (dB)	Insertion Loss (maximum)	VSWR (maximum)	RoHs
0.2 to 6 GHz	M	3	4205-95.5	95.5	0.5	8.50 dB	2.0	<input checked="" type="checkbox"/>

RoHs compliance dependent on attenuator installed. Some attenuators are NOT compliant.

Physical Dimensions

Standard 19 in Rack Unit up to 8 channels:

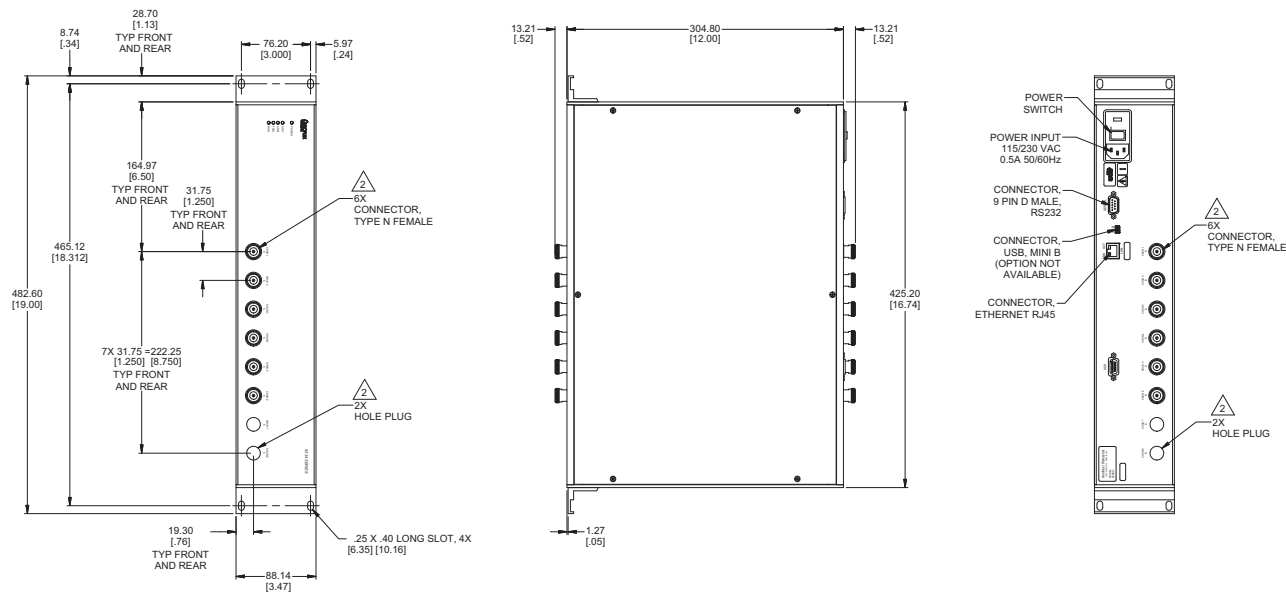

NOTE:

1. All dimensions are given in mm (inches).
2. Connectors and hole plugs are installed as required and determined by number of channel in unit. Six channel unit shown.
3. Connector location (Front/Rear) may vary depending on Model ordered.

Programmable Attenuators



Model 8312 High Power Programmable Attenuator



RS232\RS422

100 Watt Hot Switching Capability



Description

Aeroflex / Weinschel's design approach uses a highly adaptable platform that allows configuration of the step attenuator to the customers requirements. When the controller requests a new attenuation level the input switch terminates the input signal into a 50 Ohm load. (See Figure 1) This input switch is **hot switchable at 100 Watts** of input power. This will remove the high power signal from the main signal path. With no signal connected to the attenuator path the controller then commands the series of relays to configure the attenuator for the requested attenuation value. Then the input switch re-connects the input signal to the attenuator path. The system can be operated with either a remote controller (IEEE-488 or RS-232) or through front panel control.

Features

- /// Available in 0-15 dB or 0-31 dB Configurations.
- /// Provides a flexible, easy to program, low cost solution for your bench test/calibration setups and subsystem applications.
- /// Relative vs. Nominal attenuation step function.
- /// DC to 13.0 GHz Operation.
- /// High Accuracy & Repeatability.
- /// Power Handling up to 100 Watts average
- /// Designed to interface with industry standard communication interfaces:
 - GPIB/IEEE-488 (HS-488 ready)
 - RS-232, RS-422
- /// Built-in monitoring for switching input power into the load in case of fan failure.
- /// **Rack Configurable:** A Rack Mounting Kit is included for easily mounting the Model 8312 into any rack or cabinet that is designed per EIA RS-310 or MIL-STD-189.

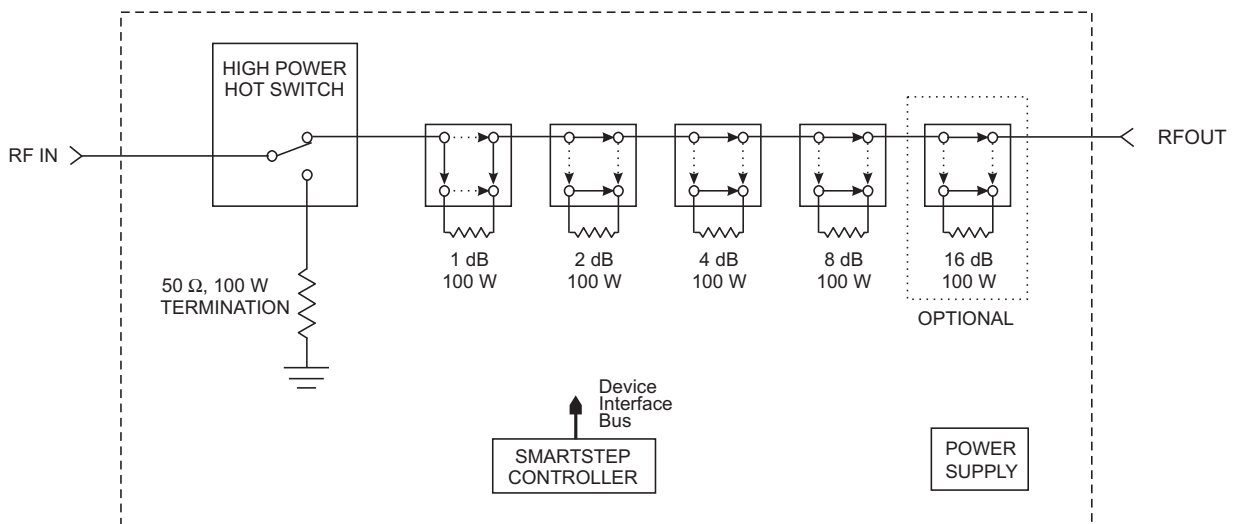

Note: If power failure should occur, the unit will remain in the last selected attenuation state.

Figure 1. Model 8312 Block Diagram

For additional information on the Model 8312, visit our website @ www.aeroflex.com/AW/8312.htm

Specifications

SPECIFICATION	DESCRIPTION		
Input Power Requirements	AC	100 to 240 Vac, 50/60 Hz, 50 Watts	
Environmental	Operating Temperature:	0 to +50°C	
	Storage Temperature:	67° to +167 °F (-55° to +75°C)	
	Humidity:	96%	
	Altitude:	40,000' (12,192M)	
IEEE-488 Bus	Connector:	24-pin per IEEE-488.1	
	Protocols:	per IEEE-488.2	
	Indicators:	Remote (RMT), Listen (LSN), Talk (TLK), SRQ (SRQ)	
RS-232 Bus	Connector:	9-pin male D	
	Signals:	TXD, RXD, RTS, CTS, DTR, GND	
	Baud Rates:	2400, 9600, 19200, and 38400	
	Data Bits:	8	
	Handshaking:	None, RTS/CTS, XON/XOFF	
	Parity:	None, Odd, Even	
	Indicators:	Tx (Transmit) and Rx (Receive)	
RS-422 BUS⁽³⁾	Connector:	9-pin male D	
	Signals:	TXD+, TDX-, RXD+, RTX-, RTS+, RTS-, CTS+, CTS- and signal GND	
	Baud Rates:	2400, 9600, 19200, and 38400	
	Data Bits:	8	
	Handshaking:	None, RTS/CTS, XON/XOFF	
	Parity:	None, Odd, Even	
	Indicators:	Tx (Transmit) and Rx (Receive)	
RF Characteristics⁽⁴⁾	Connectors:	Type N, Female	
	Frequency Range:	dc - 13 GHz	
	Impedance:	50 Ω	
	SWR:	50 MHz - 5 GHz:	1.60 (Maximum)
		5 GHz - 13 GHz:	2.30 (Maximum)
	Attenuation Range:	15 dB/1 dB steps (8312-15-F)	
		31 dB/1 dB steps (8312-31-F)	
	RF Power Rating:	50 MHz - 5 GHz:	100 Watts (Maximum)
		5 GHz - 13 GHz:	50 Watts (Maximum)
	Attenuation Settings:	100, 000 selections (minimum)	
	Attenuation Update Rate:	1 second (Typical)	
	Incremental Accuracy:	<u>Frequency</u>	<u>1-15 dB</u> <u>16-31 dB</u>
		50 MHz - 3 GHz:	+0.6 dB +0.8 dB
		3 GHz - 5 GHz:	+0.6 dB +0.8 dB
		5 GHz - 13 GHz:	+2.5 dB +3.0 dB
	Insertion Loss (dB):	<u>Frequency Range</u>	<u>8312-15-X</u> <u>8312-31-X</u>
		50 MHz - 3 GHz:	3.0 3.5
		3 GHz - 5 GHz:	4.0 4.5
		5 GHz - 13 GHz:	7.0 8.0

1. GPIB/IEEE-488 model allows user-selectable addresses.

2. RS-232 can be used with standard PC serial port for short and medium distances (up to approximately 50 ft).

3. RS-422, designed for very long distance communications (4000 ft) and optimized as a single node protocol, typically with one device connected to a single port.

4. Refer to Individual data sheet for detailed specifications on internal programmables.

Programmable Attenuators



Physical Dimensions

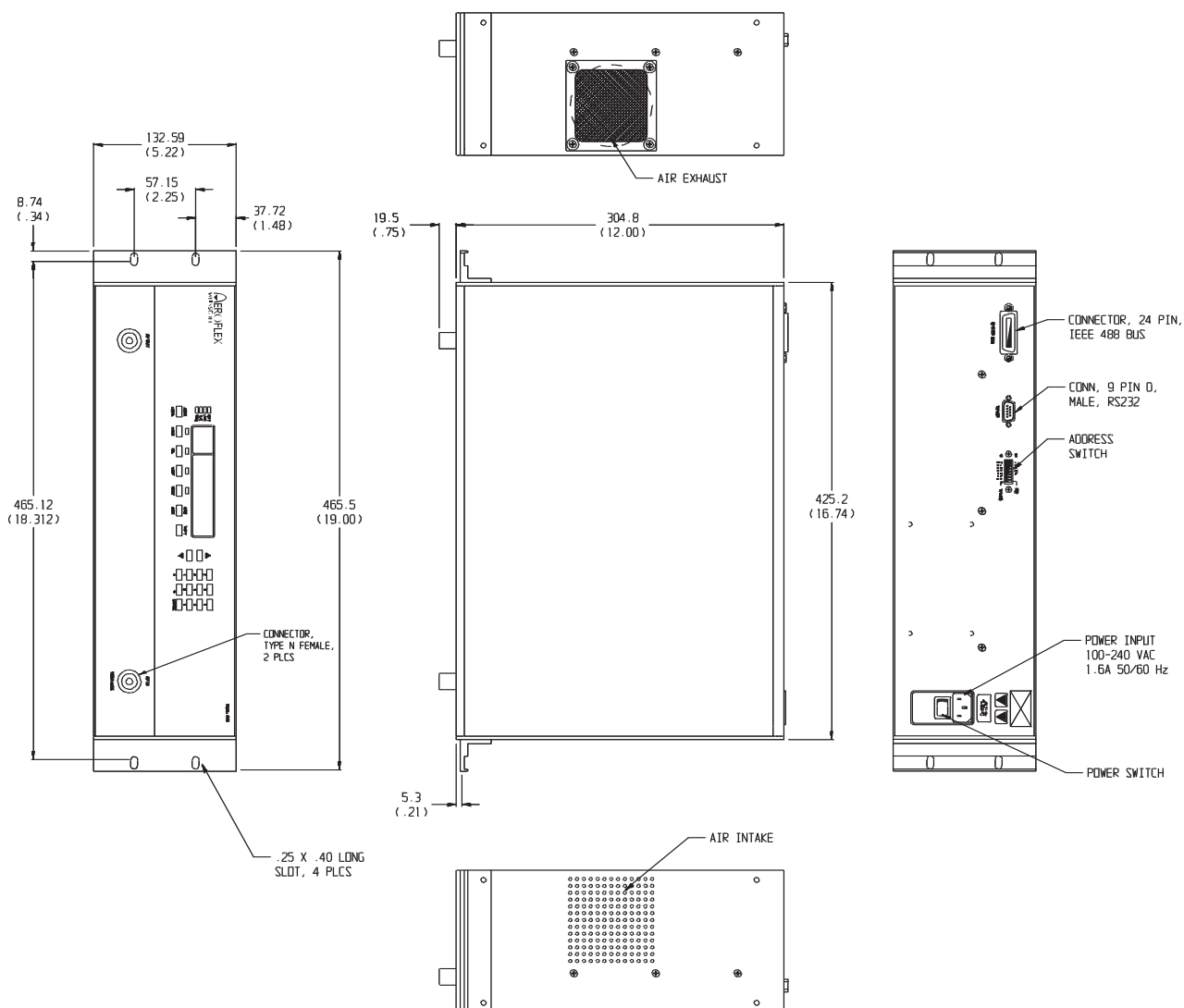

NOTE: All dimensions are given in mm (inches) and are maximum, unless otherwise specified.

MODEL NUMBER DESCRIPTION:

Example:

8312 - XX - X

Basic Model Number	Attenuation Value (dB)*	Connector Location F = Front R = Rear
--------------------------	----------------------------	---

* Available in 0-15 dB and 0-31 dB configurations only!

Model 8210A SmartStep® Programmable Attenuator/ Switch Controller



RS232/RS422/RS485



A Logical Interface for Switchable Devices!



Features

- /// Provides a flexible, powerful, low cost solution for bus control of programmable step attenuators and other switchable devices under computer control.
- /// Designed to interface with Aeroflex / Weinschel's line of intelligent programmable attenuators and other electromechanical devices.
- /// Simplifies your bench test setups and subsystem design.
- /// Available in two standard communication interfaces:
 - Model 8210A-1: GPIB/IEEE-488 (HS-488 ready)
 - Model 8210A-2: RS-232, RS-422, RS-485

Description

Model 8210A represents a new concept in device control applications and provides a high level interface from various industry standard communications interfaces to the serial Driver Interface Bus.

The Device Interface Bus (DIB) is a system for connecting a number of relatively low-speed I/O devices to a host, providing a simple, uniform and inexpensive way to control a variety of devices via a single port. The DIB is based on the two-wire serial bus and several software protocol layers that allow the Model 8210A to address up to 125 peripheral devices with serial data rates of up to 100 KHz. The DIB may also be used to supply DC power to the devices, resulting in a simple, low-cost interconnection system.

This Programmable attenuator/switch controller is available in two models, each providing a different type of communications interface to suit user configuration requirements. Each model contains similar capabilities, and provides switch-selectable parameters to the interfaces' operation.

Applications

Applications for the 8210A range from providing control of a single Programmable Attenuator in a bench test/lab environment using a PC and a terminal emulator, to complex system applications where the 8210A is employed to control many devices to create custom/semi-custom subsystems to reduce overall design cost. Aeroflex / Weinschel can provide a variety of custom designed driver interfaces for various devices, such as RF switches, relays, PIN attenuators, displays and other devices, as well as complete subsystem design and integration services. Contact us with your specialized needs.

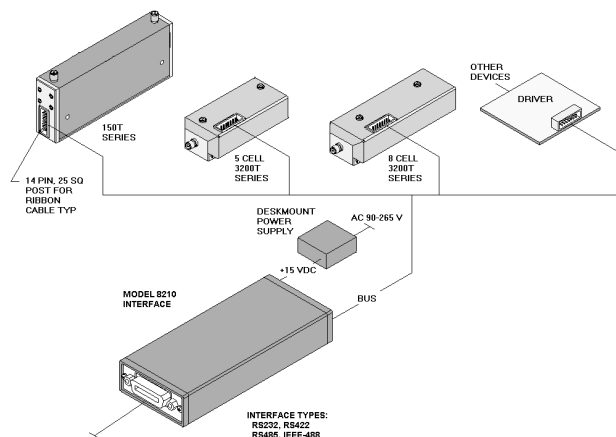

Typical Capacity: Control a subsystem consisting of 32 individual 8-cell programmable attenuators plus 16 DPDT switches.

Accessories:

PART NUMBER	DESCRIPTION
001-378	Deskmount Power Supply, +15 V 95-250 Vac, 47-63 Hz ac input
193-8013	Interconnect Cable
193-8012	Attenuator Mounting Kit: This kit includes all hardware to allow the user to mount one attenuator onto the Model 8210A

For additional information on the Model 8210A, visit our website @ www.aeroflex.com/AW/8210A

Programmable Attenuators



Specifications

SPECIFICATION	DESCRIPTION
DC Input	Connector: 2.5mm barrel style Requirements: +12 to +15 Vdc @ 250 mA
Driver Interface	Connector: 14-pin 0.025" square post header @ 0.1" centers. Mates with AMP 746285-2 or equivalent. Signals : SDA serial data SDC serial clock VDC DC supply voltage GND ground VDC Output Current: 2 A maximum Maximum Cable Length: 10 Meters (1000 pF maximum capacitance) Data Transfer Rate: 100 KHz
Environmental	Operating Temperature: 0 to +50°C Storage Temperature: -55° to +75°C (67° to +167°F) Humidity: 95% Altitude: 40,000' (12,192M)
IEEE-488 Bus⁽¹⁾	Connector: 24-pin per IEEE-488.1 Protocols: per IEEE-488.2 Indicators: Remote, Listen
RS-232 Bus⁽²⁾	Connector: 9-pin male D Signals: TXD, RXD, RTS, CTS, DTR, GND Baud Rates: 2400, 9600, and 19200, 38400 Data Bits: 8 Handshaking: None, RTS/CTS, XON/XOFF Parity: None, Odd, Even Indicators: Tx (Transmit) and Rx (Receive Active)
RS-422 Bus⁽³⁾ & RS-485 Bus⁽⁴⁾	Connector: 9-pin male D(Model 8210-2) Signals: TXD+, TDX-, RXD+, RTX-, RTS+, RTS-, CTS+, CTS-, & signal GND Baud Rates: 2400, 9600, and 19200, 38400 Data Bits: 8 Handshaking: None, RTS/CTS, XON/XOFF Parity: None, Odd, Even Indicators: Tx (Transmit) and Rx (Receive Active)

Notes:

1. GPIB/IEEE-488 model allows user-selectable addresses.
2. RS-232 can be used with standard PC serial port for short and medium distances (up to approximately 50 ft).
3. RS-422, designed for very long distance communications (4000 ft) & optimized as a single node protocol, typically with one device connected to a single port.
4. RS-485, designed for very long distance communications (4000 ft) & optimized for multi-drop connections that can used to create a low cost network.

Physical Dimensions

Model 8210A-1 (IEEE-488):

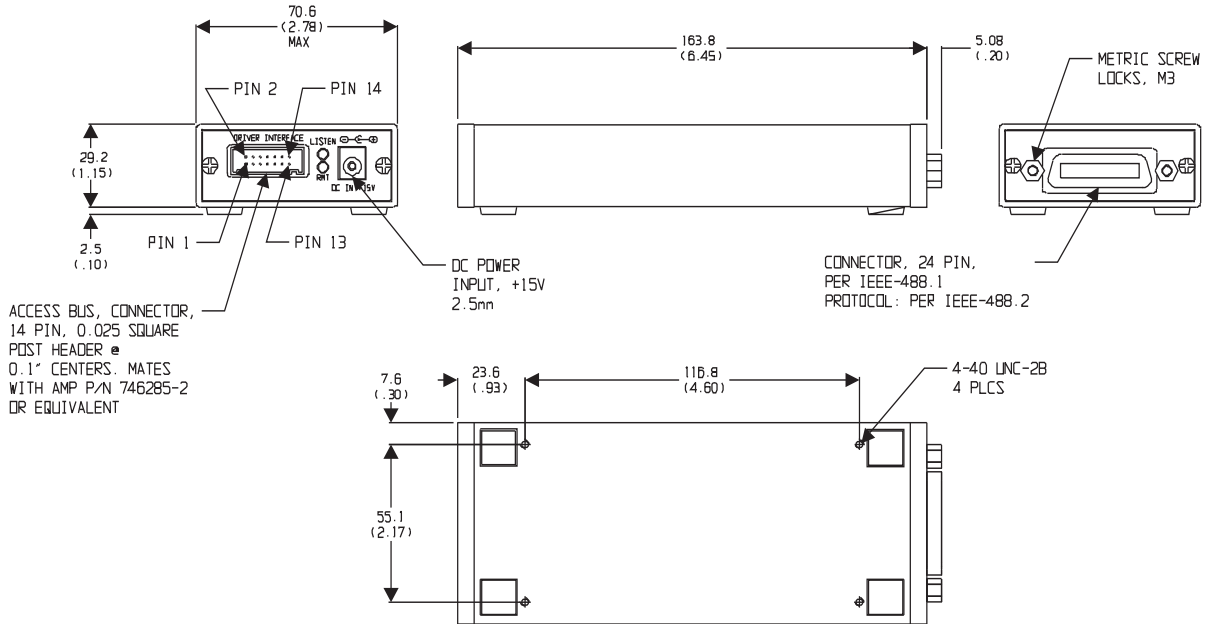

Model 8210A-2 (RS-232/RS-422/RS-485):

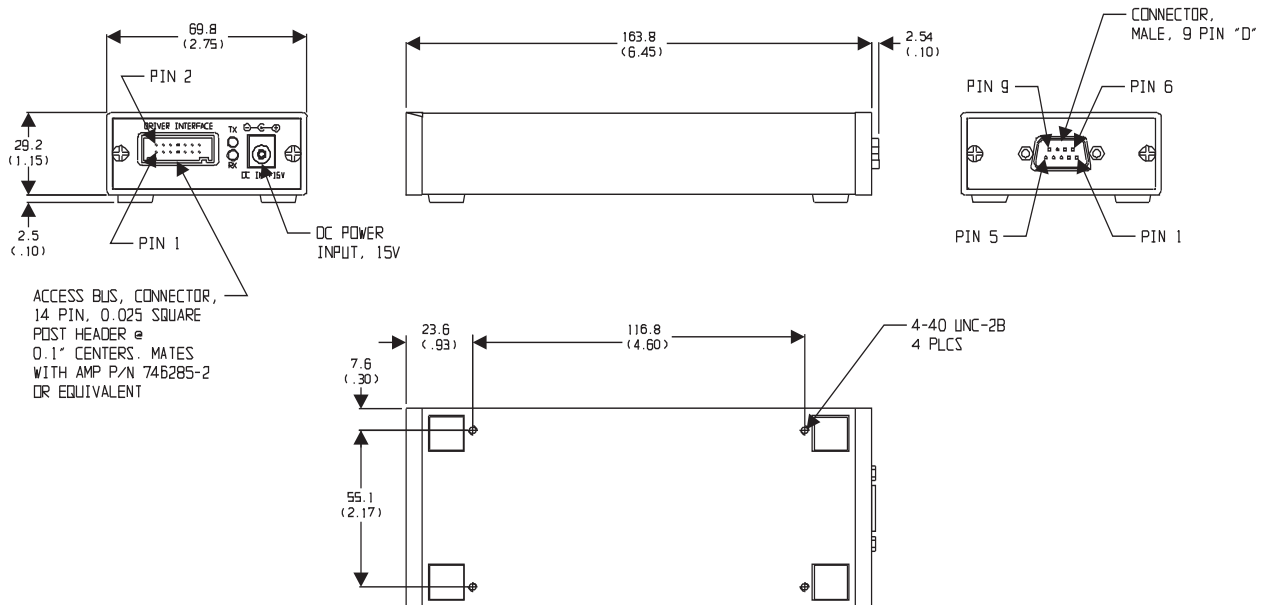

NOTE:

1. All dimensions are given in mm (inches) and are maximum, unless otherwise specified.
2. Unit weight: 318 g (11.2 oz)

Subsystems & Accessories . . .



Aeroflex / Weinschel develops and manufactures high quality microwave and RF subsystems for a wide range of applications such as, RF distribution systems, switch matrices, attenuation matrices, RF link simulators, mobile unit fading simulators and cellular / cable test systems.

Aeroflex / Weinschel's subsystem products are employed in OEM and system test environments, standards laboratories, manufacturing and test departments, engineering development facilities, telephone (Mobile & VoIP) networks, military qualification and conformance verification labs of communications and aerospace companies, as well as government agencies and private research firms throughout the world. Applications include satellite and ground communications systems, cable modem signal switching, cell telephone testing, telecommunications, radar, OEM, signal analysis, air traffic control, and precision microwave related instruments and system use. Aeroflex / Weinschel's subsystems products and capabilities include:

- /// Switch Matrices
- /// Complex RF Distribution Networks
- /// Attenuation Matrices & Multi-Channel Subsystems
- /// Mobile Unit (Radio & WLAN) Fading Simulators
- /// Subsystems with Low IM Performance
- /// Cable Modem Redundant Switches and Test Systems
- /// Programmable Attenuators with Built-In Digital Interface
- /// Custom Module and Mechanical Applications

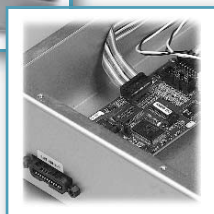

Subsystem Product Overview . . .

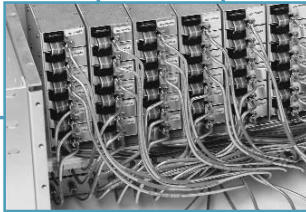

Multi-Channel Attenuation Subsystems

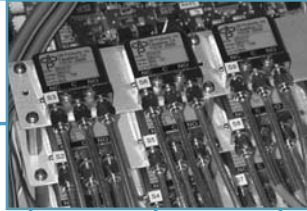

Switch Matrices

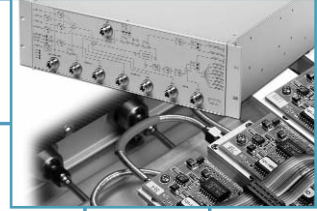

Complex RF Subsystems



RF Translator Subsystems



Mobile Unit Fading Simulators

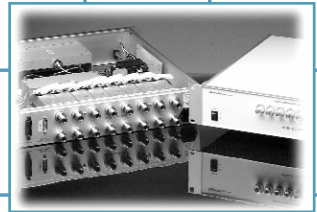

Cellular & Wireless Test Solutions



Cable Modem Redundant Switches



Programmable Attenuator & Controllers

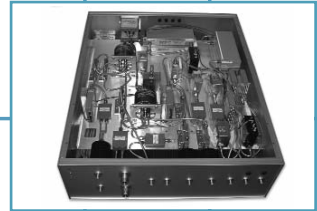

Customized Mechanical Packaging

Aeroflex / Weinschel's Subsystem technology streamlines system designs and device integration by providing both a flexible bus interface and components that are simple to configure and control.

Creating subsystems using Aeroflex / Weinschel's unique approach streamlines the design and layout of application specific subsystems that include a wide range of microwave and RF components such as programmable/fixed attenuators, power combiners/dividers/splitters, directional couplers, amplifiers, filters, noise sources and switches which can be controlled using various standard communications interfaces including IEEE-488, RS232, RS422, Ethernet (SNMP option) and RS485. Subsystem design options can also include:

- /// Turnkey subsystems built to customer specified design & layout.
- /// Wide dynamic and frequency ranges.
- /// Low Phase Noise Design and Testing.
- /// Front panel and menu controls.
- /// Attenuation/switching schemes.
- /// Customer specified Input/Output parameters.
- /// Individual to complex matrix/channel configurations.
- /// Specialized testing and calibration.



Attenuation Matrices



Custom Configurations & Design

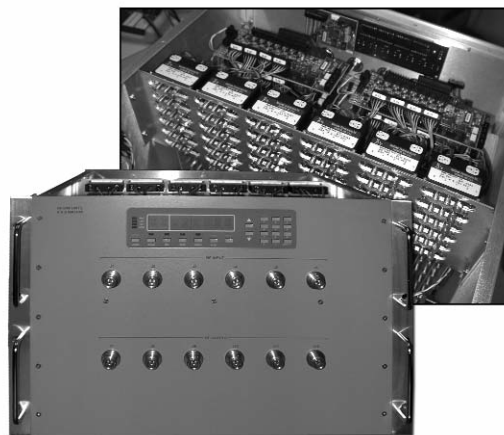
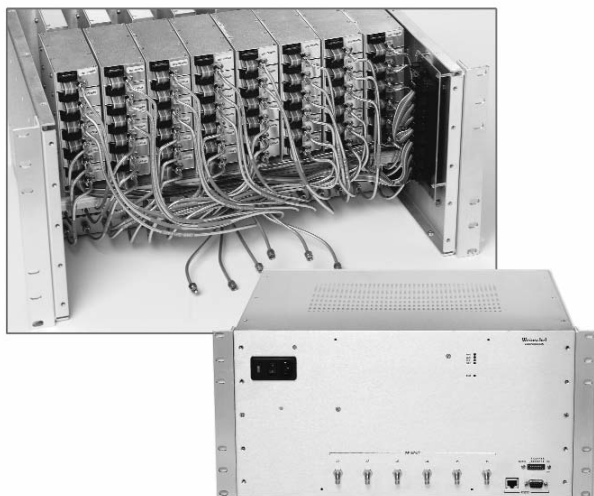

Description

Aeroflex / Weinschel has designed and manufactured numerous versions of Attenuation Matrices for various applications. These units have typically been built in configurations that include 2x6, 3x6, 4x6, 6x6, 4x4, 4x8 and 8x8 configurations. For the typical UMTS, CDMA 2000, and GSM bands the units can operate over 800 -3 GHz frequency range. However multiple units have been built for other applications and span the frequency range of DC to 18 GHz in multiple sub-band configurations.

The attenuation units available include all available Aeroflex / Weinschel programmable attenuators (relay based, PIN and GasFet types) and can be controlled using industry standard interfaces such as IEEE-488, RS-232 and Ethernet (10 BaseT).

Typical Specifications

Typical specifications for an 8 x 8 UMTS configuration are:

- /// Frequency Range: 800 MHz to 3 GHz
- /// Attenuation Range: 127 dB / 1 dB steps
- /// Impedance: 50 Ω nominal
- /// Insertion Loss: 25 dB @ 800 MHz (Target)
- /// 30 dB @ 3 GHz (Target)
- /// SWR: 1.50 maximum
- /// RF Power Input: 0 dBm average
- /// +30 dBm without damage
- /// Isolation Input to Input: 40 dB minimum
- /// Isolation Output to Output: 35 dB minimum

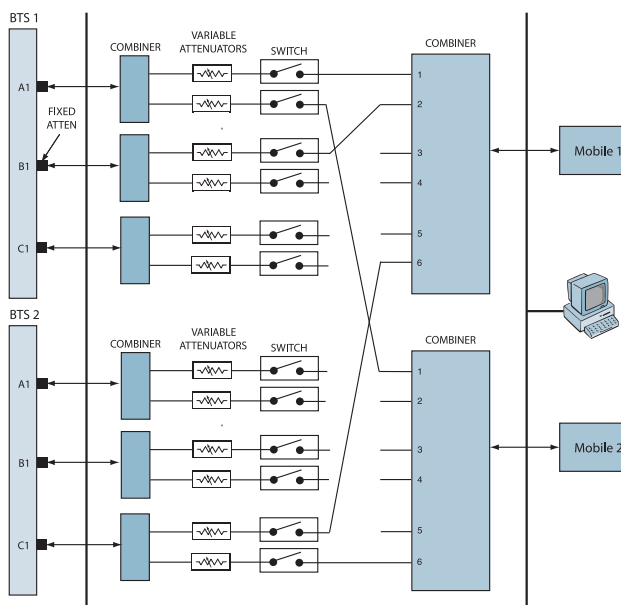

Optional Specifications:

- /// High Isolation configurations
- /// Phase Compensated Paths
- /// High Power Inputs
- /// Fast Switching Configurations
- /// Front Panel Control
- /// Ethernet Control (10BaseT)

Switch Matrices & RF Distribution Subsystems

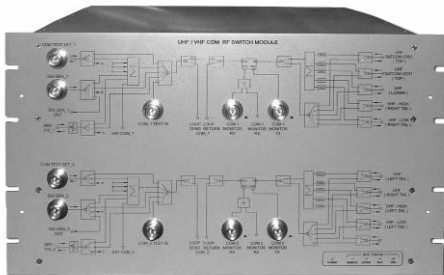
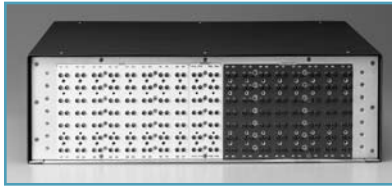

Description

Aeroflex / Weinschel designs and manufactures custom switch matrices. The matrices consist of 50Ω and 75Ω designs with high isolation and gain flatness being critical performance parameters within our designs.

Designs are constructed using coaxial components for high frequency microwave applications, GaAs MMIC Switching design for fast switching applications and surface mount board designs for lower frequency, high density applications.

Typical Features

GaAs MMIC Switching Design:

- /// Frequency Range: 3.4-4.2 GHz
- /// Gain, any path: -14±1.5 dB @ 3.8 GHz @ 20°C
- /// Gain Bal between Channels: ±1.0 dB max @ 3.8 GHz
- /// Gain Stability ±0.2 dB over +/- 5°C
- /// Gain Variation vs. Frequency:
 - +0.20 dB over any 40 MHz segment
 - +0.50 dB over any 80 MHz segment
 - ±1.5 dB over any 3.4-4.2 GHz
- /// Isolation (minimum):

Input/Input	60 dB
Input/Output	60 dB
Output/Output	60 dB
(different input)	
- /// Noise Figure: 15 dB maximum
- /// VSWR (50 Ω):

Input:	1.3:1 maximum
Output:	1.5:1 maximum

75 Ω System - Board Design:

- /// Front Panel Serviceability: No down time for RF paths.
- /// All active modules are front panel replaceable using simple tools.
- /// 10 Base T Ethernet control (SNMP)
- /// Module Hot Swap capability.
- /// Modularity/Serviceability
- /// Input and Output Impedances: 75 Ω
- /// Maximum RF Input Power: +15 dBm
- /// Switch Type: Electro-mechanical, absorptive
- /// Frequency Range: 54 to 860 MHz
- /// Insertion Loss: -5.5 dB
- /// Flatness: ±1.1 dB
- /// Return Loss: > 15.5 dB
- /// Isolation: > 60 dB

Coaxial Designs:

- /// Full Access Blocking Design
- /// 0.03 dB switch repeatability
- /// 5 Million switch cycles minimum
- /// 50 Ohm system
- /// Latching relays
- /// IEEE-488 and RS-232 control
- /// Frequency: DC-20 GHz
- /// Impedance: 50 ohm
- /// VSWR (maximum):

DC - 4 GHz	1.43:1
4 - 12 GHz	1.65:1
12 - 18 GHz	1.8:1
18 - 20 GHz	2.2:1
- /// Insertion Loss: 3 dB typical
4 dB maximum @ 20 GHz
- /// Insertion Loss Repeatability: 0.05 dB typical

Subsystems & Accessories



Model 8314-1 Model 8314-2 WLAN System Simulator

2.0 to 4.0 GHz
2.0 to 6.0 GHz

Simulate Connectivity over Distance & Speed



Description

This specialized subsystem is used to simulate the connectivity between a mobile unit running along a line of 3 base stations spaced from 250 to 1000 meters apart. The test subsystem is able to simulate the variation of the RF signal from the base stations reaching the mobile (as well as the signal from the mobile reaching the base stations) when the mobile is moving at speeds of up to 250 km/h. Several variations of this have been developed and produced.

The simulator attenuates the simulated Base Station signal through three independent attenuators, then combines the signals. Each attenuator has a dynamic range of 60 dB in 1 dB steps. The operation of the unit is via a RS232 interface, ASCII commands can input parameters into the controller. Upon receiving a trigger the controller executes the program to simulate the link loss to all three Base Stations as seen from the mobile transceiver.

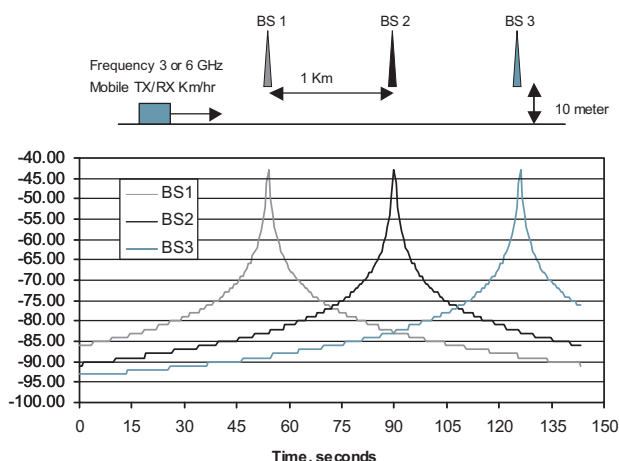

Calculated signal level from each Base Station.

(mobile unit moving at 100 km/hr)

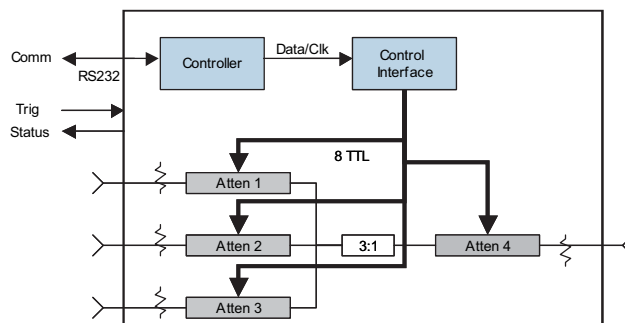

Figure 1. RF Simulator Block Diagram

TRIGGER: The signal to begin a run can be either a hardware based trigger generated external from the controller, or via RS232 command. If it is desirable to synchronize the beginning of a train run with other external hardware/ software, a hardware based trigger is recommended. The controller will also output a status signal to indicate that the train is running. Once triggered, this signal is active for the duration of the run.

OPERATOR CONTROLLED PARAMETERS: Using the RS-232 control interface the operator has the ability to control the following parameters to set up any mobile unit simulation:

- /// Base Station Positions (X meters, A station, B station, C station, + offset from the track), 0-3000 meters for station positions and 10-100 meters for offset from the track.
- /// Mobile Transceiver Start/Stop Position (x , y meters): 0-10, 000 meters.
- /// Mobile Velocity (Y km/hr): 0-250 km/hr
- /// Time Resolution (1,10,100,1000 mS or auto to fill memory)
- /// Frequency: 2 to 6 GHz
- /// Ant Gain for Mobile and Base Station
- /// Transmitter Antenna Gain: -10 to +10 dB
Receiver Antenna Gain: -10 to +10 dB
- /// Loop Command: Used to simulate the train running in a continuous loop.

For additional information on the Model 8314, visit our website @ www.aeroflex.com/AW/8413.htm

Specifications

SPECIFICATION	DESCRIPTION	
Input Power Requirements	ac	100 to 240 Vac, 50/60 Hz, 50 Watts
Environmental	Operating Temperature	0 to +50°C
	Storage Temperature:	67° to +167 °F (-55° to +75°C)
	Humidity:	96%
	Altitude:	40,000' (12,192M)
RS-232 Bus	Connector:	9-pin male D
	Signals:	TXD, RXD, RTS, CTS, DTR, GND
	Baud Rates:	2400, 9600, 19200, and 38400
	Data Bits:	8
	Handshaking:	None, RTS/CTS, XON/XOFF
	Parity:	None, Odd, Even
	Indicators:	Tx (Transmit) and Rx (Receive)
RF Characteristics	Attenuator (Qty 4):	Pin diode design
	Attenuation Range/Step Size:	0-63.75 dB/ 0.25 dB step
	Incremental Attenuation Accuracy:	+5% of selected value
	Frequency:	Model 8314-1: 2.0 - 4.0 GHz Model 8314-2: 2.0 - 6.0 GHz
	Configuration:	3 inputs, 1 output
	Impedance:	50 ohm
	Insertion Loss:	27 dB
	RF Input Power (P1dB):	+25 dBm
	RF Connector:	N Female
	VSWR:	1.75:1 Target
	Port to Point Isolation:	>40 dB

1. RS-232 can be used with standard PC serial port for short and medium distances (up to approximately 50 ft).

Physical Dimensions

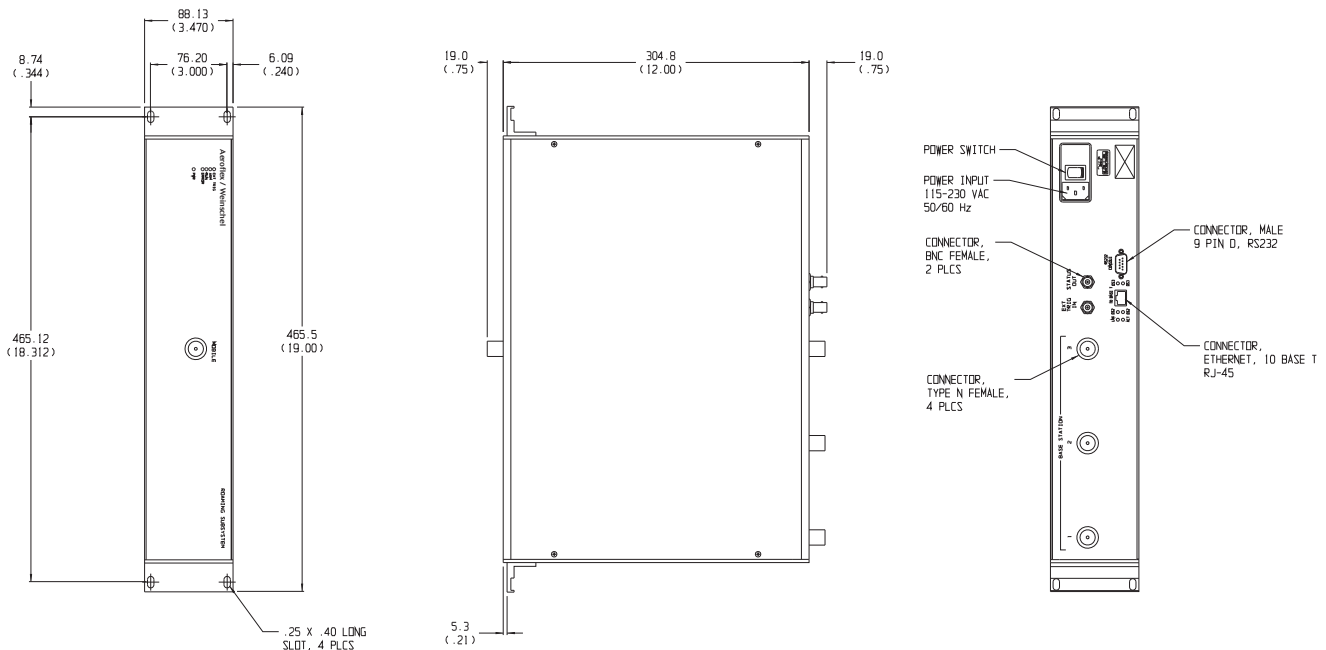

Model 10044 Programmable Attenuator/Switch Unit

dc to 6.0 GHz



Ethernet (10/100 BaseT) Control



Description

Aeroflex / Weinschel's Model 10044, Attenuator/Switch Unit (Figure 1) is comprised of a step attenuator and a two-position SPDT switch. The attenuator is a relay-based step attenuator (Model 3408-103) that provides 0-103 dB of attenuation in 1 dB steps. The common port of the RFSW is connected internally to the attenuator, and can be used to provide either single input/dual output or dual input/single output functionality, as the unit is bidirectional in nature. The unit includes a front-panel interface for status and control, and supports programming via a serial RS232 port and/or 10/100BaseT Ethernet port.

Features

- /// Low profile half rack space saving design
- /// Provides a flexible, easy to program, low cost solution for your bench test/calibration setups and subsystem applications.
- /// DC to 6.0 GHz Operation.
- /// Designed to interface with industry standard communication interfaces:
 - Ethernet (10/100BaseT)
 - RS-232 (Serial)
- /// Other configurations and attenuation values and attenuator types available.

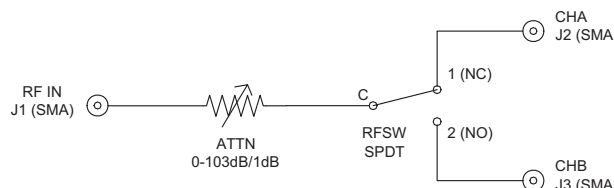

Model 10044 Schematic Diagram

Specifications

SPECIFICATION	DESCRIPTION	
Input Power Requirements	AC	90 to 260 Vac, 57/63 Hz, Single phase, 25 Watts
Environmental	Operating Temperature Storage Temperature:	0 to +50°C 67° to +167 °F (-55° to +75°C)
Ethernet TC/IP	10 Base T Connector: Console Connector:	Standard RJ45 9-pin male D
RF Characteristics	Port Connectors: Frequency Range: Impedance: Switch Life: Switching Speed (Switch): RF Power Input: RF Insertion Loss: VSWR (All Ports): RF Isolation (J1-J2/J3, J2-J3):	SMA Female 2000 to 4000 MHz minimum, dc to 6 GHz typical 50 Ω 1 X 10 cycles, minimum 20 mseconds maximum +30 dBm C.W maximum 4.9 dBm (0 dB attenuation Setting) 1.5:1 maximum (referenced to 50 Ω) 70 dB minimum

For additional information on our subsystem capabilities, visit our website @ www.aeroflex.com/weinschel

Physical Dimensions

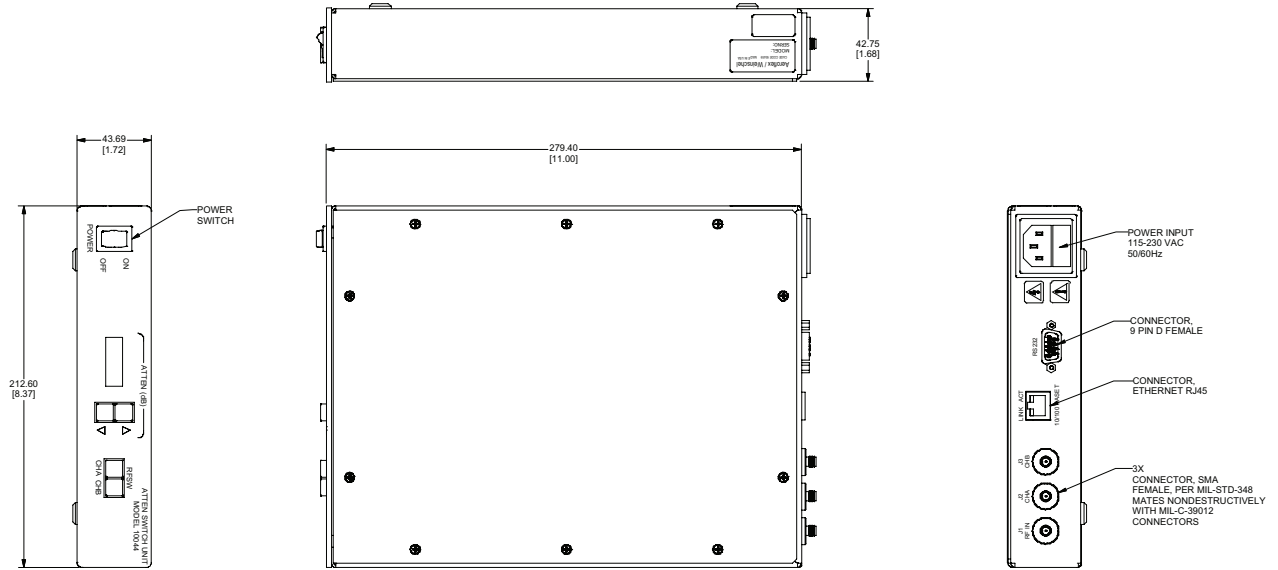

NOTE: All dimensions are given in mm (inches) and are maximum, unless otherwise specified.



Model 8390 & 8390-1 Amplifier / Switch Units



Features

- /// Provides a flexible, easy to program, low cost solution for your bench test/calibration setups and subsystem applications.
- /// Choice of Frequency Ranges.:
 - Model 8390: 3.4 to 4.2 GHz
 - Model 8390-1: 0.95 to 13 GHz
- /// Designed to interface with industry standard communication interfaces:
 - RS-232 / Serial
 - Ethernet Control (10/100 BaseT)
- /// Can be rack mounted into any rack or cabinet designed per EIA RS-310 or MIL-STD-189.

Description

Aeroflex / Weinschel's Models 8390 and 8390-1, Amplifier / Switch Unit is comprised of an eight-position terminating input switch (S1), an RF amplifier, and a relay-based step attenuator that provides 0-103 dB of attenuation in 1dB steps. The unit includes a front-panel interface for status and control, and supports programming via a serial RS232 port and/or 10/100BaseT Ethernet port.

Specifications

Frequency Range:	Model 8390:	3.4 to 4.2 GHz
	Model 8390-1:	0.95 to 13 GHz
P1 dB INPUT:	Model 8390:	-5 dBm
	Model 8390-1:	-2.2 dBm minimum
P1 dB OUTPUT (0 dB in the ATTEN):	Model 8390:	+26.0 dBm minimum
	Model 8390-1:	+23.5 dBm minimum
VSWR:	2:1 Typical	
IMPEDANCE:	50 Ω nominal	
PATH GAIN (0 dB in the ATTEN):	Model 8390:	31.5 dBm typical
	Model 8390-1:	26.7 dB minimum
CONTROL INTERFACE:	Ethernet 10/100 BASE-T	
NOISE FIGURE:	Model 8390:	10.0 dB Typical (0 dB ATTEN. state)
	Model 8390-1:	10.0 dB Typical (0 dB ATTEN. state)
ATTENUATION. RANGE:	Model 8390:	103 dB / 1 dB steps
	Model 8390-1:	31 dB / 1 dB steps
TEMPERATURE RANGE:	0 TO +50°C	
INPUT POWER:	115 to 230 Vac, 50/60 Hz	
WEIGHT:	TBA	

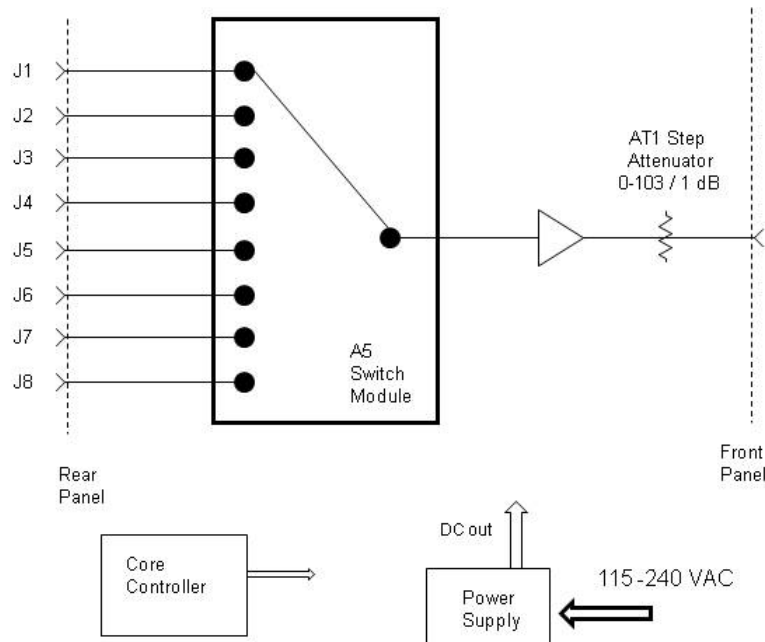
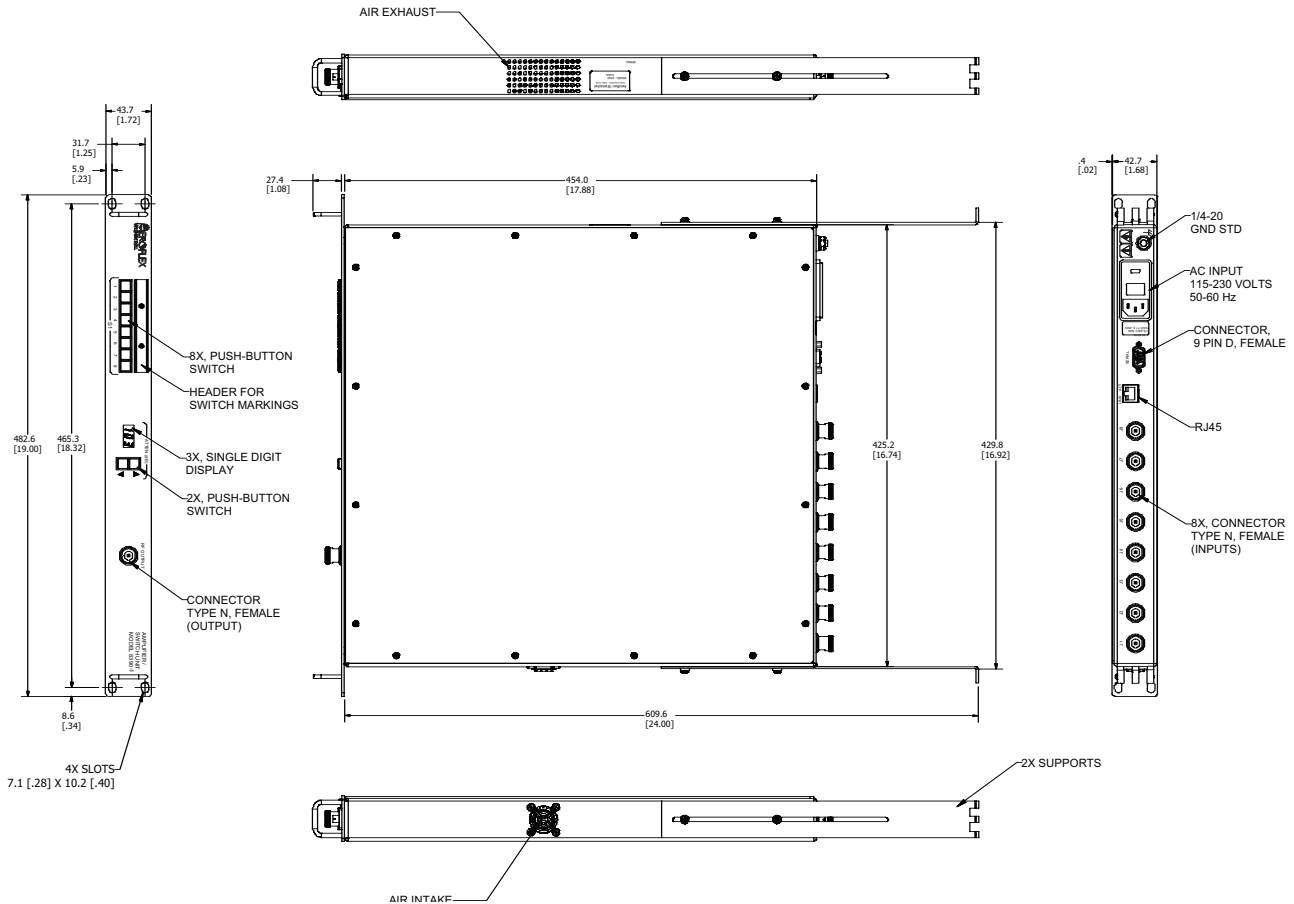

Figure 1. Model 8390 & 8390-1 System Block Diagram

PHYSICAL DIMENSIONS



NOTE: All dimensions are given in mm (inches) and are maximum, unless otherwise specified.

EXPORT CONTROL:

This product is controlled for export under the International Traffic in Arms Regulations (ITAR). A license from the U.S. Department of State is required prior to the export of this product from the United States.

EXPORT WARNING:

Aeroflex's military and space products are controlled for export under the International Traffic in Arms Regulations (ITAR) and may not be sold or proposed or offered for sale to certain countries. (See ITAR 126.1 for complete information.)

Model 8501 High Power Programmable Switch 100 Watt Hot Switching Capability



RS232\RS422



Description

Aeroflex / Weinschel's 8501 Series provides front-panel and computer control for up to two channels of high power RF switching (Figure 1), where RF signals are routed through either the front or rear mounted switch port connectors labeled 1, C, 2.

Special configurations designed to specific customer requirements may contain other coaxial devices such as power combiners, directional couplers, and filters to create single or multi-channel subsystems. The 8501 can also contain and control a separate programmable attenuator channel.

Features

- /// Provides a flexible, easy to program, low cost solution for your bench test/calibration setups and subsystem applications.
- /// Single or Dual Switch Configurations
- /// DC to 13.0 GHz Operation.
- /// Power Hot switching up to 100 Watts average
- /// Designed to interface with industry standard communication interfaces:
 - GPIB/IEEE-488 (HS-488 ready)
 - RS-232, RS-422
- /// Rack Configurable: Using a Rack Mounting Kit allows the Model 8501 to be easily mounted into any rack or cabinet that is designed per EIA RS-310 or MIL-STD-189.

MODEL NUMBER DESCRIPTION:

Example:

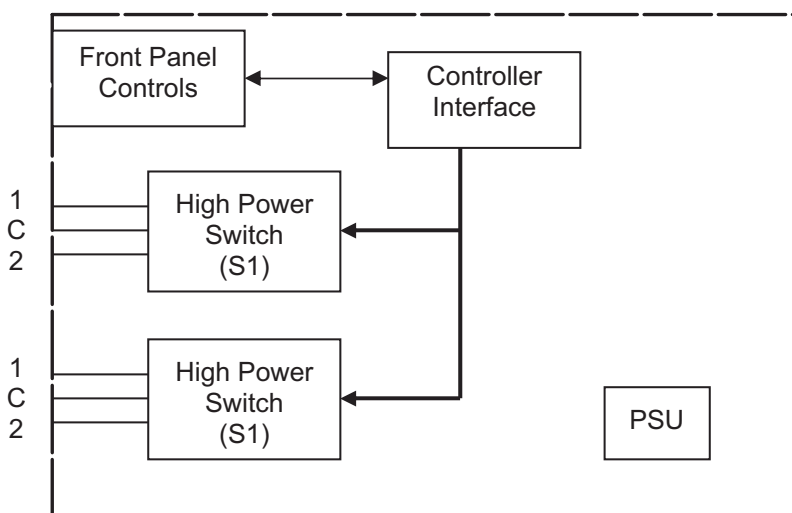
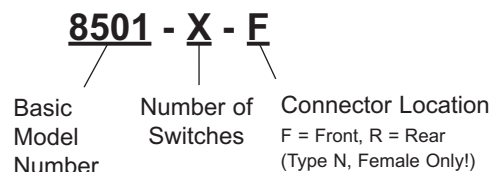

Figure 1. Model 8501 Block Diagram

For additional information on the Model 8501, visit our website @ www.aeroflex.com/AW/8501.htm

Specifications

SPECIFICATION	DESCRIPTION	
Input Power Requirements	AC	100 to 240 Vac, 50/60 Hz, 50 Watts
Environmental	Operating Temperature	0 to +50°C
	Storage Temperature:	67° to +167 °F (-55° to +75°C)
	Humidity:	96%
	Altitude:	40,000' (12,192M)
IEEE-488 Bus	Connector:	24-pin per IEEE-488.1
	Protocols:	per IEEE-488.2
	Indicators:	Remote (RMT), Listen (LSN), Talk (TLK), SRQ (SRQ)
RS-232 Bus	Connector:	9-pin male D
	Signals:	TXD, RXD, RTS, CTS, DTR, GND
	Baud Rates:	2400, 9600, 19200, and 38400
	Data Bits:	8
	Handshaking:	None, RTS/CTS, XON/XOFF
	Parity:	None, Odd, Even
	Indicators:	Tx (Transmit) and Rx (Receive)
RS-422 BUS⁽³⁾ signal GND	Connector:	9-pin male D
	Signals:	TXD+, TDX-, RXD+, RTX-, RTS+, RTS-, CTS+, CTS-, and
	Baud Rates:	2400, 9600, 19200, and 38400
	Data Bits:	8
	Handshaking:	None, RTS/CTS, XON/XOFF
	Parity:	None, Odd, Even
	Indicators:	Tx (Transmit) and Rx (Receive)
RF Characteristics	Port Connectors:	Type N, Female
	Frequency Range:	dc - 13 GHz
	Impedance:	50 Ω
		<u>DC to 3</u> <u>3 to 5</u> <u>5 to 11</u> <u>11 to 13</u>
	SWR (maximum):	1.25 1.45 1.70 1.70
	Insertion Loss (dB maximum):	0.25 0.30 0.50 0.65
	Isolation (dB maximum):	70 60 50 50
	RF Average Power Handling (CW):	100 W to 3 GHz 50 W to 13 GHz
	Hot Switch Cycling:	100K @ 100 Watts CW @ 2 GHz

1. GPIB/IEEE-488 model allows user-selectable addresses
2. RS-232 can be used with standard PC serial port for short and medium distances (up to approximately 50 ft).
3. RS-422, designed for very long distance communications (4000 ft) and & optimized as a single node protocol, typically with one device connected to a single port.

Physical Dimensions

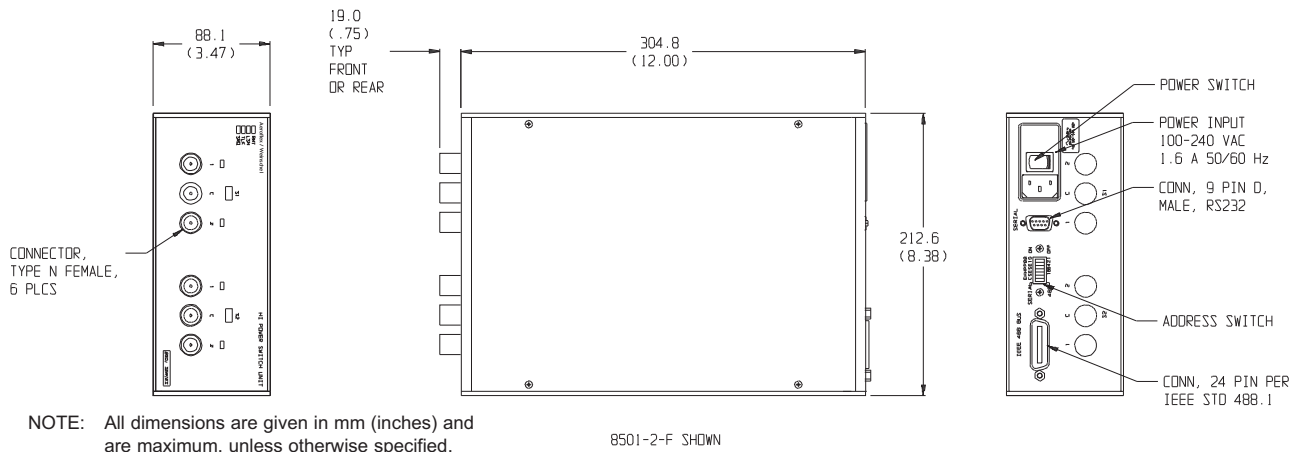

Model 8502
Programmable Switch Unit
Local, Ethernet, USB & RS-232 Control

up to 18 GHz



Features

- /// Can be configured with up to 14 each, SP6T Switches
- /// Front panel local control and display make it ideal for lab and manual test environments
- /// DC to 18 GHz Operating Frequency Range
- /// Integrated Switch Cycle Counter
- /// Failsafe & Latching switching configurations available
- /// Accuracy & Repeatability.
- /// Low Insertion Loss and High Isolation
- /// Supplied with industry standard communication interfaces:
 - Ethernet (10/100 BaseT)
 - USB 2.0
 - RS-232 (Serial)
 - GPIB/IEEE-488 (HS-488 ready) optional
- /// Labview based Attenuation Control Software included
- /// Compact 2 RU, 19" Rack Mount Configuration

Applications

- /// User can remotely control up to 14 switches through a single connection
- /// Can be configured into multiple full-blocking matrices using external coaxial cables. Some examples for these matrices are: 2 x 2 and 3 x 3 with redundant paths, up to 6 x 6
- /// Can also be configured as a single pole, multi-throw (up to 1 x 66 throw) switch in addition to many other complex switching configurations
- /// The Failsafe version has a break-before-make operation which is suitable for non-contiguous applications while the Latching version has a make-before-break that can be suitable for high power signals

Description

Aeroflex / Weinschel's 8502 Series Programmable Switches represent a new streamlined approach in programmable switches for bench test and subsystem applications. Standard 8502 Series designs house and control up to 14 failsafe or latching electrometrical switches via front panel controls, Ethernet, USB and Serial communications interfaces. A GPIB/IEEE-488 interface is also available as an option.

The 8502 Series can be configured as a single input multi-channel configuration or can be configured for up to 14 channels each, SP6T switches interconnected externally in a variety of matrix arrangements or used independently.

Aeroflex / Weinschel also provides custom subsystems where a variety of test configurations can be incorporated within a single unit. Contact us with your specialized needs.

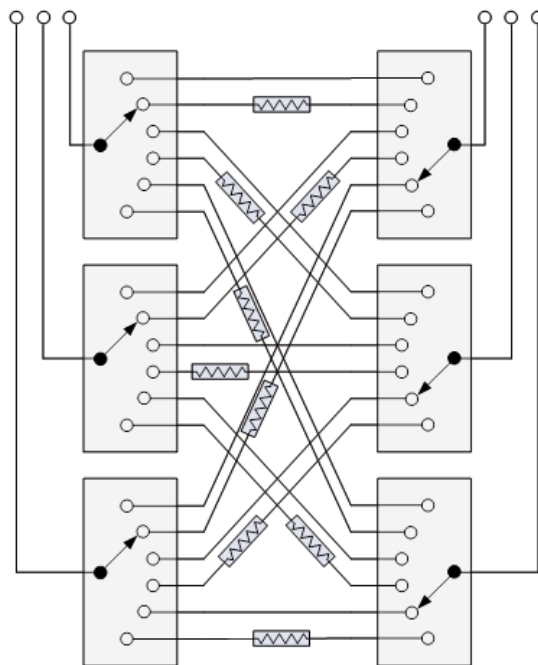

Sample Application Diagram

For additional information on the Model 8502, visit our website @ www.aeroflex.com/AW8502

Specifications

SPECIFICATION	DESCRIPTION																									
Input Power Requirements	ac 100 to 240 Vac, 50/60 Hz, 180 Watts																									
Environmental	Operating Temperature: 0° to +50°C Storage Temperature: -40° to +167 °F (-40° to +75°C) Humidity: 96% (non-condensing) Altitude: 40,000' (12,192M)																									
RS-232 Bus (1) Serial I/O	Connector: 9-pin male D Signals: TXD, RXD, RTS, CTS, GND Baud Rates: 9600 to 230400 Data Bits: 8 Handshaking: None, RTS/CTS Parity: None																									
USB 2.0	Connector: Mini B																									
Ethernet	10/100 Base T Connector: Standard RJ45																									
IEEE-488 Bus (2) (GPIB option)	Connector: 24-pin per IEEE-488.1 Protocols: per IEEE-488.2																									
RF Characteristics	Nominal Impedance: 50 Ω Frequency Range: DC-18 GHz <table border="1" style="margin-left: 20px;"> <thead> <tr> <th></th> <th>DC-3</th> <th>3-8</th> <th>8-12.4</th> <th>12.4-18</th> </tr> </thead> <tbody> <tr> <td>VSWR (maximum):</td> <td>1.2:1</td> <td>1.3:1</td> <td>1.4:1</td> <td>1.5:1</td> </tr> <tr> <td>Insertion Loss (maximum):</td> <td>0.2 dB</td> <td>0.3 dB</td> <td>0.4 dB</td> <td>0.5 dB</td> </tr> <tr> <td>Isolation (minimum):</td> <td>75 dB</td> <td>70 dB</td> <td>60 dB</td> <td>60 dB</td> </tr> <tr> <td>Average Power (Typical)⁽³⁾:</td> <td>95 W</td> <td>55 W</td> <td>45 W</td> <td>35 W</td> </tr> </tbody> </table> Switching Action: Failsafe to Open (For Switch Option "F") Make Before Break (For Switch Option "L") Switching Time (maximum): 15 msec Life (minimum per position) ⁽³⁾ : 1 X 10 ⁶ cycles		DC-3	3-8	8-12.4	12.4-18	VSWR (maximum):	1.2:1	1.3:1	1.4:1	1.5:1	Insertion Loss (maximum):	0.2 dB	0.3 dB	0.4 dB	0.5 dB	Isolation (minimum):	75 dB	70 dB	60 dB	60 dB	Average Power (Typical) ⁽³⁾ :	95 W	55 W	45 W	35 W
	DC-3	3-8	8-12.4	12.4-18																						
VSWR (maximum):	1.2:1	1.3:1	1.4:1	1.5:1																						
Insertion Loss (maximum):	0.2 dB	0.3 dB	0.4 dB	0.5 dB																						
Isolation (minimum):	75 dB	70 dB	60 dB	60 dB																						
Average Power (Typical) ⁽³⁾ :	95 W	55 W	45 W	35 W																						

- RS-232 can be used with standard PC serial port for short and medium distances (up to approximately 50 ft).
- GPIB/IEEE-488 model allows user-selectable addresses, (Not included on standard models, must be ordered as an option).
- Hot switching is limited to 1 W CW maximum switching at higher power levels will reduce the life or the switch in terms of insertion loss accuracy repeatability.

Model Number Configuration Matrix

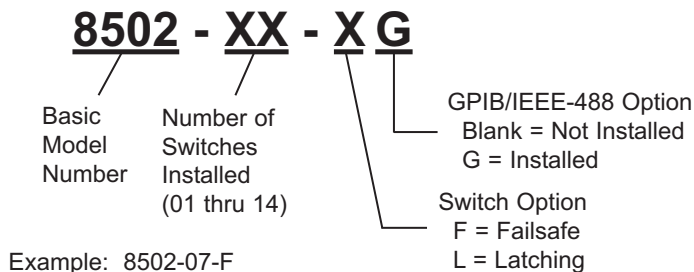

Programmable Switches



Physical Dimensions

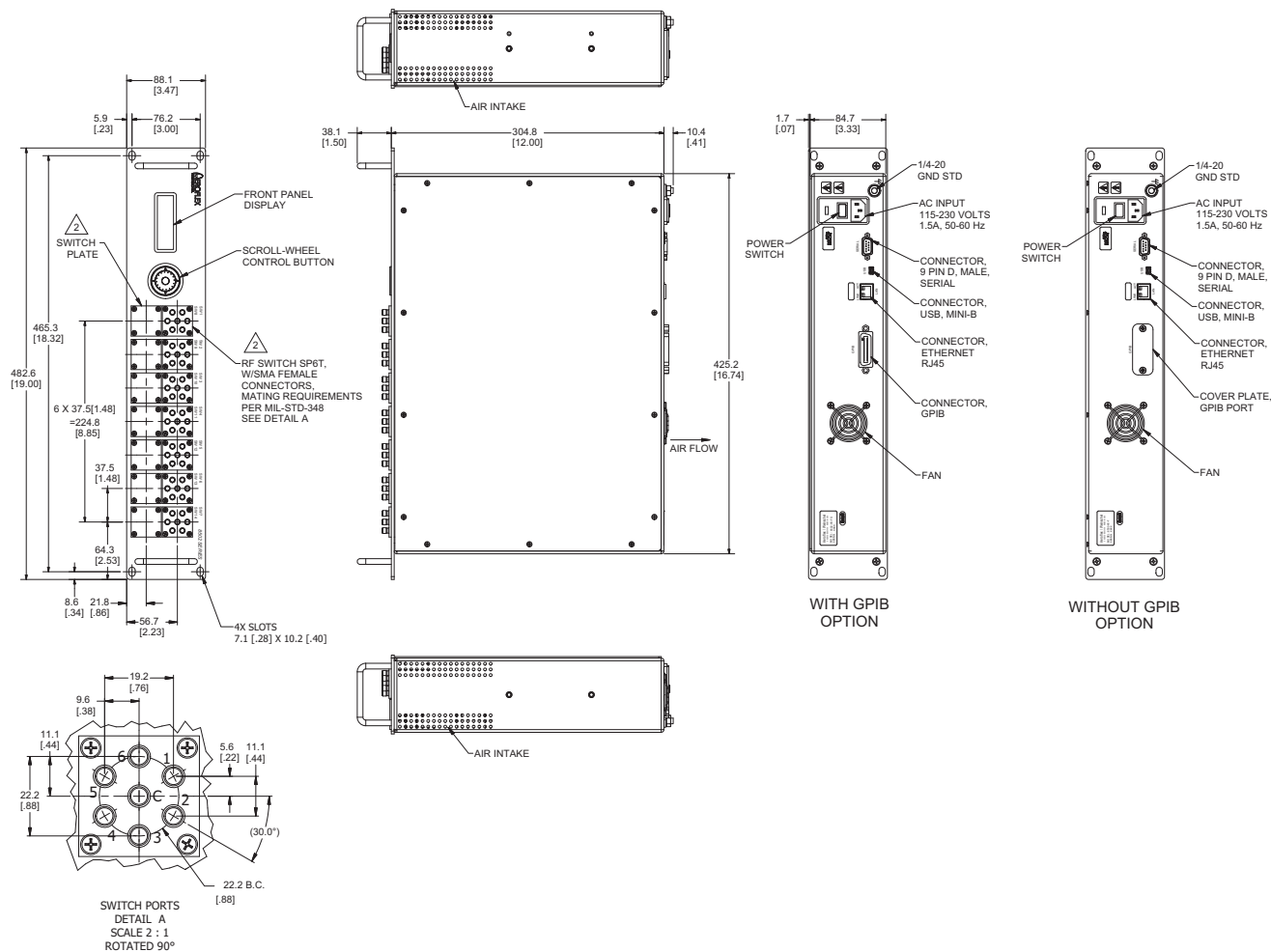

NOTE:

1. All dimensions are given in mm (inches).
2. RF Switches and switch plates as required and determined by configuration. Seven switch unit configuration shown.

Model 8304-5 RF Switching Subsystem *Simplifies Mobile Radio Testing*

DC to 2 GHz

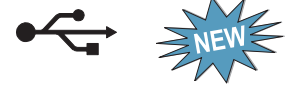

Features

- /// DC - 2 GHz Frequency Range
- /// 50 Ohm Impedance
- /// 5 Radio Interfaces
- /// RS-232 Control

Description

Aeroflex /Weinschel's Model 8304-5 RF Switching System is part of an automated test set-up for various types of commercial and military radios. The difference in the test set up and configuration between different types of radios will be the control interconnect cables used.

The block diagram below shows the RF Switch Subsystem which is designed to control and test up to 5 radios at a time. The Aeroflex Test Solutions 3900 Series Digital Radio Test Set (Customer provided) will be used as the controller, signal stimulus and measurement instrument. The Aeroflex

Wichita Model 3901 Digital Radio Test Set is connected to the Aeroflex / Weinschel RF Switching Subsystem to enable the total system to automatically connect signals to 5 radios. The RF signals are routed through an electro-mechanical switch.

All switching selection occurs via the USB control port located on the rear panel of the Model 8304-5. The RF Switching System is an RF subsystem that utilizes an internal Micro Computer to provide control of the switches and relays via the USB to serial interface.

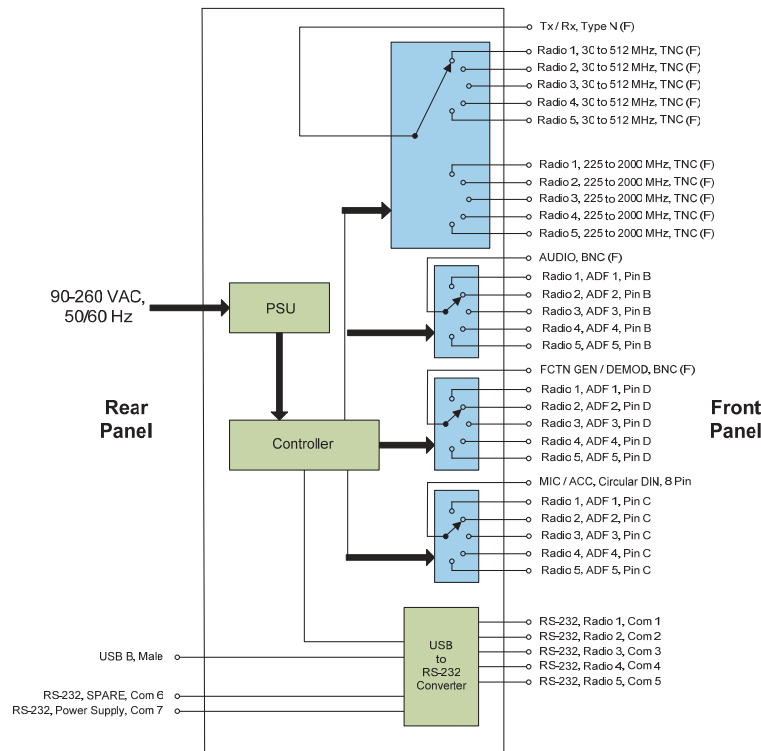

Figure 1. Block Diagram, Model 8304-5

Specifications

SPECIFICATION	DESCRIPTION																						
Input Power Requirements	AC 115/230 Vac, 50/60 Hz, 1.5 A Connector per IEC320																						
Environmental Operating	Temperature 0 to +50°C Storage Temperature -40° to +167 °F (-40° to +75°C)																						
USB to 8 Serial Ports Adapter	<table border="0"> <tr> <td>Connector</td> <td>9-pin male D</td> </tr> <tr> <td>Number of Ports</td> <td>8</td> </tr> <tr> <td>Signals</td> <td>TXD, RXD, RTS, CTS, DTR, DSR, DCD, GND</td> </tr> <tr> <td>Speed</td> <td>up to 921.6 kbps</td> </tr> <tr> <td>Driver</td> <td>Windows 98, ME, 2000, XP, 2003 Server, Vista, Linux (Kernel 2.4 and up built-in)</td> </tr> <tr> <td colspan="2">Indicators (Front Panel) Tx (Transmit) and Rx (Receive)</td> </tr> </table>	Connector	9-pin male D	Number of Ports	8	Signals	TXD, RXD, RTS, CTS, DTR, DSR, DCD, GND	Speed	up to 921.6 kbps	Driver	Windows 98, ME, 2000, XP, 2003 Server, Vista, Linux (Kernel 2.4 and up built-in)	Indicators (Front Panel) Tx (Transmit) and Rx (Receive)											
Connector	9-pin male D																						
Number of Ports	8																						
Signals	TXD, RXD, RTS, CTS, DTR, DSR, DCD, GND																						
Speed	up to 921.6 kbps																						
Driver	Windows 98, ME, 2000, XP, 2003 Server, Vista, Linux (Kernel 2.4 and up built-in)																						
Indicators (Front Panel) Tx (Transmit) and Rx (Receive)																							
RF IN / OUT	<table border="0"> <tr> <td>Frequency Coverage</td> <td>DC - 2000 MHz</td> </tr> <tr> <td>Impedance</td> <td>50 Ω nominal</td> </tr> <tr> <td>VSWR</td> <td>1.3:1 maximum</td> </tr> <tr> <td>Pin (CW maximum)</td> <td>+30 dBm hot switching +43 dBm carrying</td> </tr> <tr> <td>Switching Operations</td> <td>1 million minimum</td> </tr> <tr> <td>Switching repeatability (System)</td> <td>+/- 0.1 dB</td> </tr> <tr> <td>Flatness</td> <td>+/- 0.5 dB</td> </tr> <tr> <td>Insertion Loss</td> <td>0.5 dB</td> </tr> <tr> <td>RF In Connector (1 Place)</td> <td>Type N Female</td> </tr> <tr> <td>RF Out Connector (10 Places)</td> <td>TNC Female</td> </tr> <tr> <td>Switching Speed</td> <td>20 mSec from receipt of command at switch</td> </tr> </table>	Frequency Coverage	DC - 2000 MHz	Impedance	50 Ω nominal	VSWR	1.3:1 maximum	Pin (CW maximum)	+30 dBm hot switching +43 dBm carrying	Switching Operations	1 million minimum	Switching repeatability (System)	+/- 0.1 dB	Flatness	+/- 0.5 dB	Insertion Loss	0.5 dB	RF In Connector (1 Place)	Type N Female	RF Out Connector (10 Places)	TNC Female	Switching Speed	20 mSec from receipt of command at switch
Frequency Coverage	DC - 2000 MHz																						
Impedance	50 Ω nominal																						
VSWR	1.3:1 maximum																						
Pin (CW maximum)	+30 dBm hot switching +43 dBm carrying																						
Switching Operations	1 million minimum																						
Switching repeatability (System)	+/- 0.1 dB																						
Flatness	+/- 0.5 dB																						
Insertion Loss	0.5 dB																						
RF In Connector (1 Place)	Type N Female																						
RF Out Connector (10 Places)	TNC Female																						
Switching Speed	20 mSec from receipt of command at switch																						
Tx Audio	<table border="0"> <tr> <td>Frequency Range</td> <td>500 Hz – 15 kHz</td> </tr> <tr> <td>Impedance</td> <td>600 Ω nominal</td> </tr> <tr> <td>Connector In</td> <td>BNC Female</td> </tr> <tr> <td>Output (5 Places)</td> <td>Pin D ADF Connector</td> </tr> </table>	Frequency Range	500 Hz – 15 kHz	Impedance	600 Ω nominal	Connector In	BNC Female	Output (5 Places)	Pin D ADF Connector														
Frequency Range	500 Hz – 15 kHz																						
Impedance	600 Ω nominal																						
Connector In	BNC Female																						
Output (5 Places)	Pin D ADF Connector																						
Rx Audio	<table border="0"> <tr> <td>Frequency Range</td> <td>500 Hz – 15 kHz</td> </tr> <tr> <td>Impedance</td> <td>600 Ω nominal</td> </tr> <tr> <td>Connector In</td> <td>BNC Female</td> </tr> <tr> <td>Output (5 Places)</td> <td>Pin B ADF Connector</td> </tr> </table>	Frequency Range	500 Hz – 15 kHz	Impedance	600 Ω nominal	Connector In	BNC Female	Output (5 Places)	Pin B ADF Connector														
Frequency Range	500 Hz – 15 kHz																						
Impedance	600 Ω nominal																						
Connector In	BNC Female																						
Output (5 Places)	Pin B ADF Connector																						
Push to Talk	<table border="0"> <tr> <td>Signal Input</td> <td>HI/GND TTL control</td> </tr> <tr> <td>Connector In</td> <td>8 pin DIN</td> </tr> <tr> <td>Output (5 Places)</td> <td>Pin C ADF Connector</td> </tr> </table>	Signal Input	HI/GND TTL control	Connector In	8 pin DIN	Output (5 Places)	Pin C ADF Connector																
Signal Input	HI/GND TTL control																						
Connector In	8 pin DIN																						
Output (5 Places)	Pin C ADF Connector																						
FUNCTION GENERATOR / DEMO MOD	<table border="0"> <tr> <td>Connector IN</td> <td>Circular DIN, 8 Pin, Female</td> </tr> </table>	Connector IN	Circular DIN, 8 Pin, Female																				
Connector IN	Circular DIN, 8 Pin, Female																						

EXPORT CONTROL:

This product is controlled for export under the International Traffic in Arms Regulations (ITAR). A license from the U.S. Department of State is required prior to the export of this product from the United States.

EXPORT WARNING:

Aeroflex's military and space products are controlled for export under the International Traffic in Arms Regulations (ITAR) and may not be sold or proposed or offered for sale to certain countries. (See ITAR 126.1 for complete information.)

Physical Dimensions:

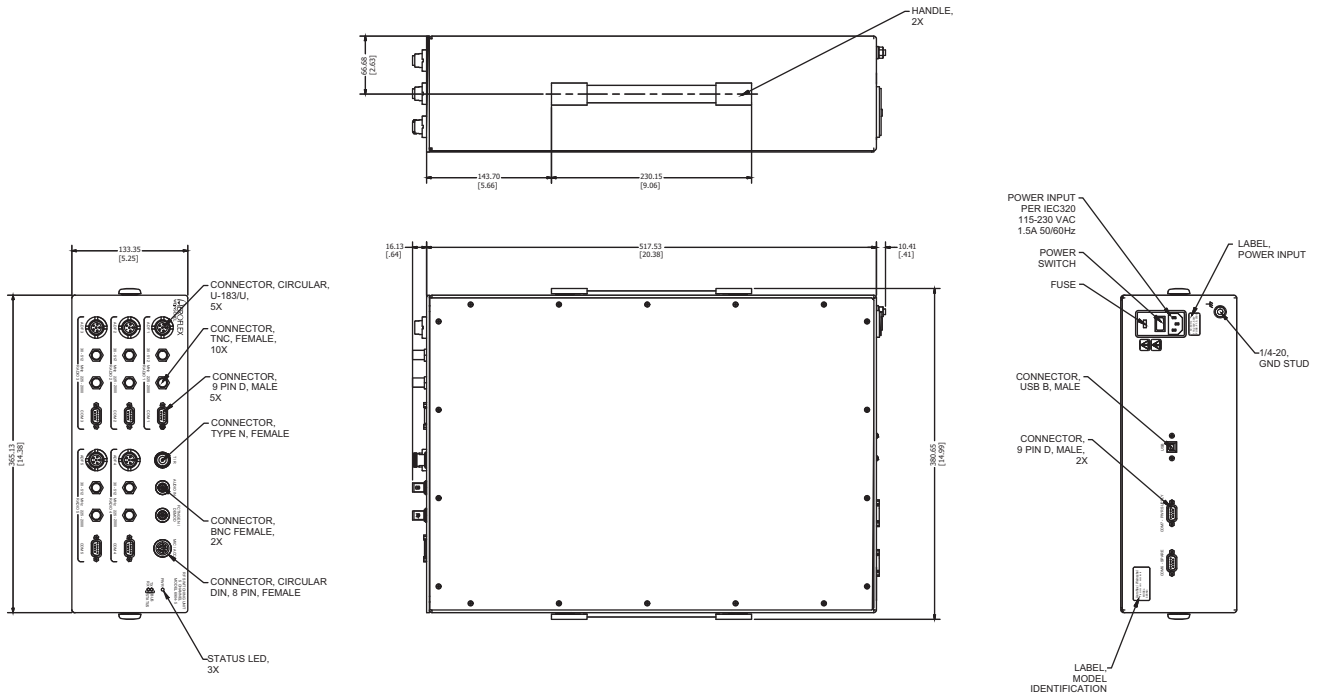

NOTE: All dimensions are given in mm (inches) and are maximum, unless otherwise specified.

Interconnect Cables

The following interconnect cables are provided:

From Aeroflex Wichita Model 3901 Digital Radio Test Set to Aeroflex / Weinschel 6904 RF Switch Subsystem

TR to RF IN	N to N	P/N 068-72-12/0
Audio IN	BNC to BNC	P/N 068-95-12/0
Funct Gen/Demod	BNC to BNC	P/N 068-95-12/0
Mic	8 pin DIN to 8 pin DIN	P/N 193-10843

From Aeroflex / Weinschel 6904 RF Switch Subsystem to Radio Under Test

30-88 MHz In/Out	TNC to TNC	P/N TBD
90 - 512 MHz In/Out	TNC to TNC	P/N TBD
ADF Connector	A3012775-2 to A3012775-2	P/N 193-1084

Model 10077 L-Band 8 X 8 Switch Matrix with Ethernet Control (10/100 BaseT)

950 to 2150 MHz



Description

Aeroflex / Weinschel's Model 10077 is a 8 x 8, Non Blocking - full fan-out Switch Matrix and is designed utilizing input isolation amplifiers, high isolation power dividers, and SP8T solid state switches (Figure 1).

This unit includes a front-panel display for status, and supports programming via a serial RS232 port and/or 10/100 BaseT Ethernet port. Position status is available via the front panel display.

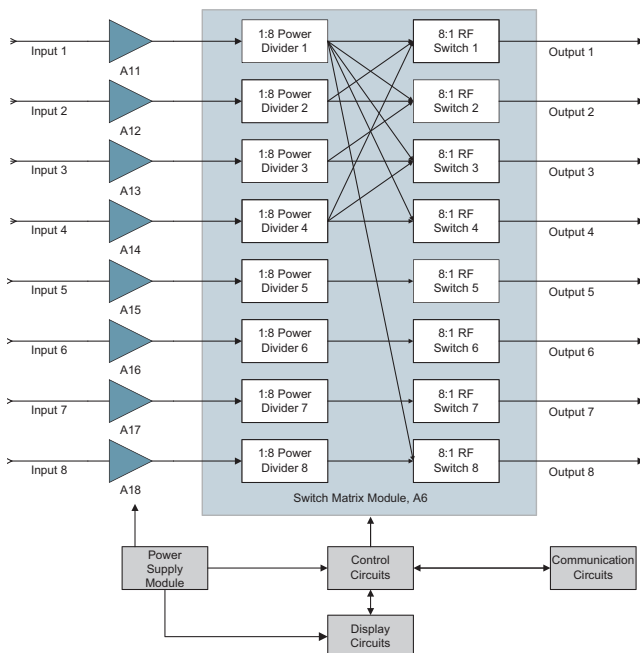

Figure 1. Model 10077 Block Diagram

Features

- /// 950 to 2150 MHz operation
- /// Non-Blocking, Full Fan-Out Configuration
- /// High Reliability, Solid State RF Switching
- /// Low Insertion Loss/High Isolation
- /// Front Panel Display
- /// Designed to interface with industry standard communication interfaces:
 - RS-232 Serial
 - Ethernet Control (10/100 BaseT)
- /// Can be rack mounted into any rack or cabinet designed per EIA RS-310 or MIL-STD-189.

Specifications

- FREQUENCY RANGE: 950-2150 MHz minimum
- IMPEDANCE: 50 Ohm nominal
- RF SWITCH TYPE: Solid-State
- SWITCHING SPEED: 500 nSEC. maximum (Switches only, does not include command processing time)
- RF POWER INPUT: -10 dBm maximum
- RF INSERTION LOSS: 6.0 dB maximum
- PASSBAND FLATNESS: Within +/-2.0 dB over 950 to 2150 MHz, within +/-0.5 dB over any 40 MHz segment
- VSWR: 1.7:1 maximum IN/OUT, referenced to 50 OHMS
- 1 dB COMPRESSION POINT: +5 dBm minimum
- NOISE FIGURE (@1550 MHz): 15 dB maximum
- RF ISOLATION;
 - INPUT TO INPUT: 60 dB minimum
 - INPUT TO OUTPUT: 60 dB minimum
 - OUTPUT TO OUTPUT: 60 dB minimum when switches are in different states
- CONTROL INTERFACE: RS-232 (9 PIN D)
Ethernet 10/100 BASE T(RJ45)
- AC POWER REQUIREMENTS: 90-260 VAC, single phase, 50-60 Hz, 1.5 A.
- TEMPERATURE RANGE,
 - OPERATING: -10 to +45 °C
 - STORAGE: -30 to +70 °C
- RELATIVE HUMIDITY: 5 TO 85% Non-codensing

Subsystems & Accessories



Physical Dimensions

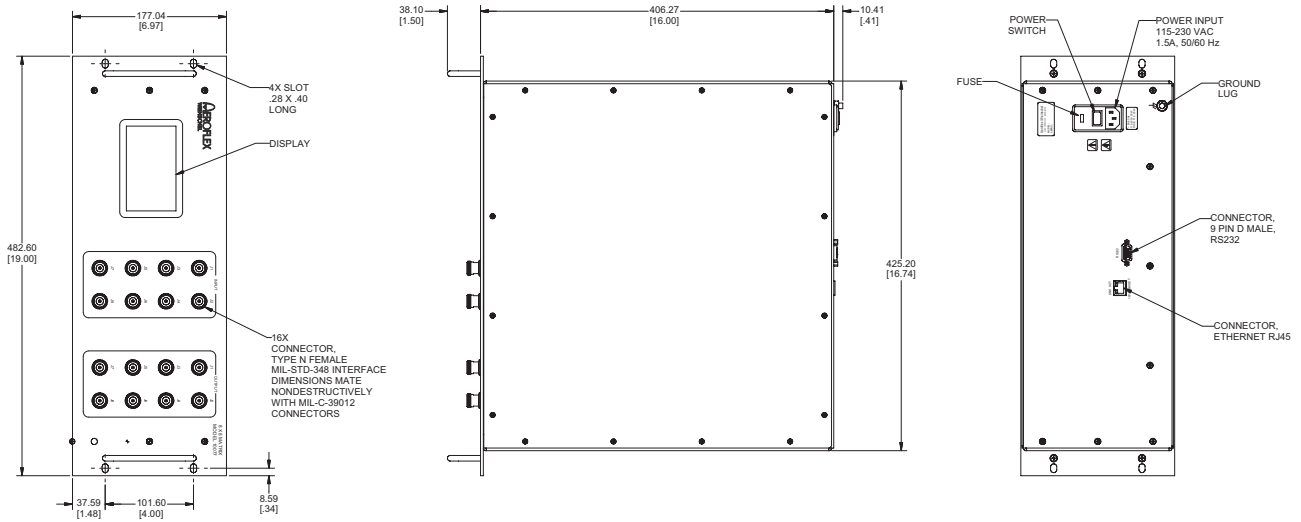

NOTE: All dimensions are given in mm (inches)

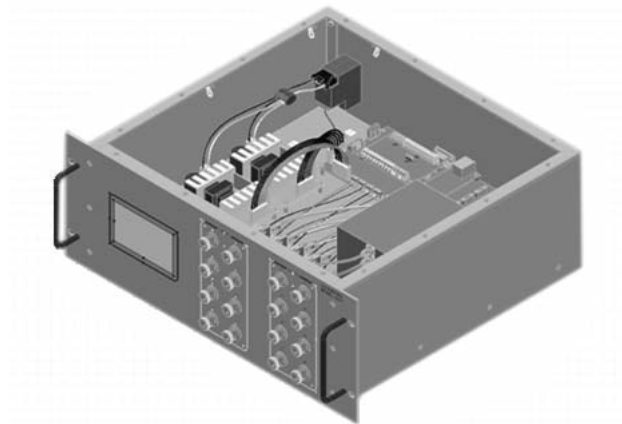

Mobile Unit Fading Simulators



Aeroflex / Weinschel designs and manufactures multi-path attenuation subsystems for fading / simulation of a broad range of applications and subsystems. This subsystem illustrated features:

- /// 400 - 3500 MHz frequency range.
- /// 16 Input Channels to 8 Output Channels. (other configurations available)
- /// RS-232 Serial Interface.
- /// Wide Dynamic Range: 127/1 dB steps.
- /// Aeroflex / Weinschel 3200T Programmable Attenuators with 8210A Controller.

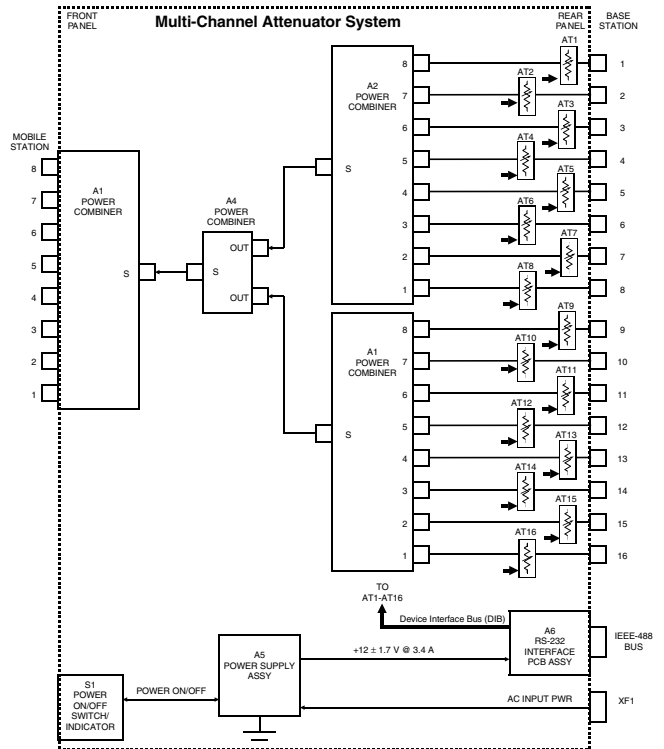

Mechanical Layout:

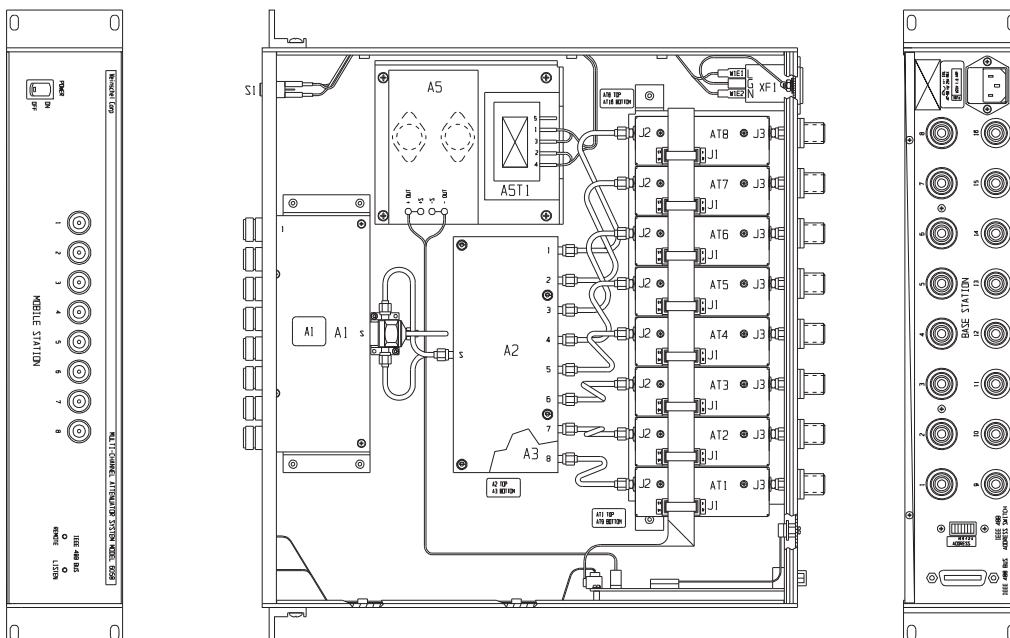

Complex Multi-Channel Attenuator

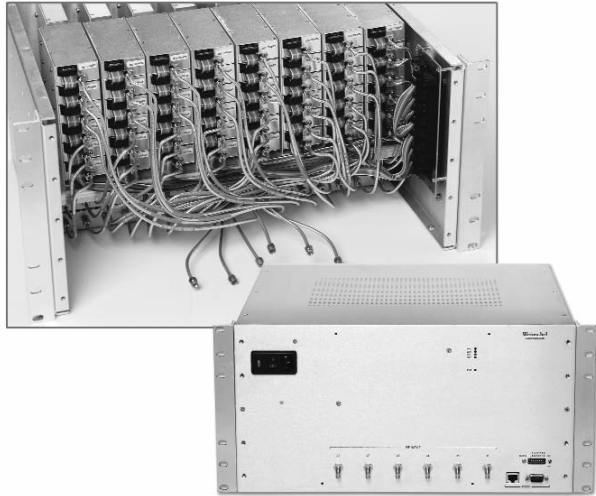

This application illustrates Aeroflex / Weinschel's ability to house and control a large number of solid-state programmable attenuators and power combiners creating a complex multichannel attenuator subsystems. Other features include:

- /// 800 MHz - 6 GHz frequency range.
- /// 6 front panel Input channels to 8 rear panel Output Channels (other configurations available)
- /// Wide Dynamic Range: 95 dB in 1 dB steps.
- /// RS-232 Serial Interface.
- /// Combiner Isolation 20 dB maximum.
- /// Designed to customer specified packaging requirements.
- /// 64 Aeroflex / Weinschel Solid-State Programmable Attenuators.
- /// Removable mounting brackets that can be located on either end of unit, can be mounted into racks or cabinets designed per EIA RS-310 or MIL-STD-189.

Mechanical Layout:

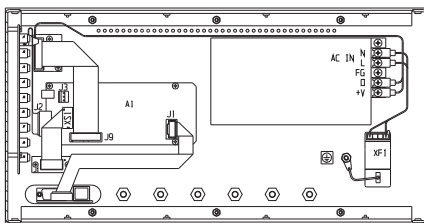

SECTION B-B

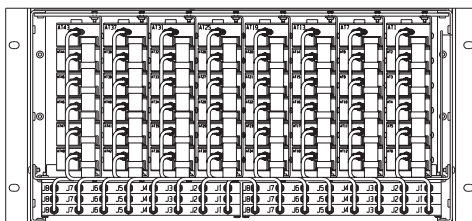
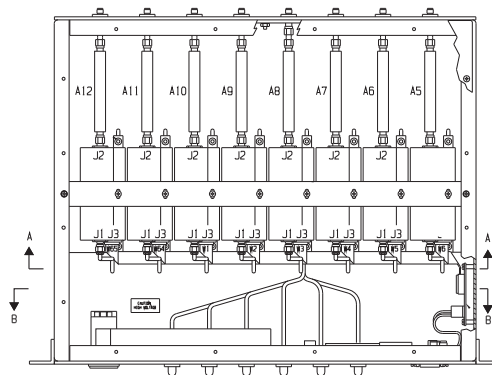

SECTION A-A

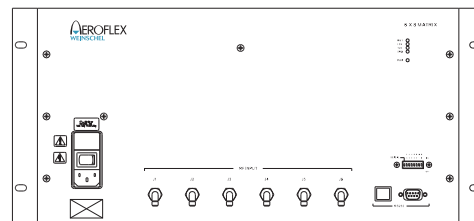

Application Specific Subsystems...

Switch Matrices & RF Distribution Networks:



Switch matrices are modularly designed which allows the end customer to order a variety of 8 x 8, 8 x 16 or 16 x 16 configurations. Switch matrices are designed using latching relays so that the signal path integrity can be maintained even during power outages or loss of IEEE-488, RS-232 and/or Ethernet control. These subsystems can be delivered either as a 50 or 75 Ω system.

Aeroflex / Weinschel's standard design approach, our designers use a highly adaptable platform that allows a dense integration of switches.

- /// Customer defined configurations, layout and packaging.
- /// Coaxial or surface mount designs available.
- /// Modular Design allows easily exchange of front and rear panel switches, controllers or power modules.
- /// IEEE-488, Serial or Ethernet (SNMP option) Interface for computer control.
- /// Switch Matrix System firmware can be controlled through a 10 Base T TCP/IP software link as well as field level software upgrades or maintenance will be available through a TCP/IP link.

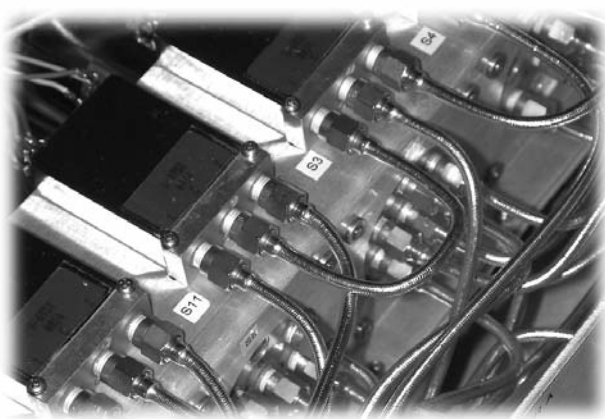

Microwave switch matrix products and subsystems are designed for Satellite Earth Stations applications such as, Uplink/ Downlink Routing, Cellular Base Stations, Metrology, Downlink and IF Signal Routing.

Cellular & Wireless Solutions:

Aeroflex / Weinschel has many years of product development experience in satellite and communications systems, test, measurement and simulation of wireless systems. This includes:



- /// WiMAX & 3G/4G Fading Simulators.
- /// Cable Modem Test Sets.
- /// Precision RF & Microwave Instrumentation.

Combining Aeroflex / Weinschel's years of experience with our subsystem design approach enables our designers to provide the wireless infrastructure market with an almost endless amount of subsystem solutions.



Cable Modem & VoIP Testing Subsystems:

The need to calibrate and test 75 Ω operational performance is critical. Aeroflex / Weinschel's testing solution starts with the design and manufacturing of 75 Ω subsystems that offer:

- /// Multi-channel inputs and outputs with front or rear panel connector mounting options.
- /// Operation over the dc to 1.2 GHz frequency range.
- /// High Isolation / Low SWR.
- /// IEEE-488, Serial or Ethernet (SNMP option) Interface for computer control.
- /// Wide dynamic range by employing Aeroflex / Weinschel Programmable Step Attenuators.
- /// Custom Mechanical Design & Layout.

For convenience, Aeroflex / Weinschel also offers standard 75 Ω attenuator units (8310-1-X) that operates over the dc-1 GHz frequency range and provides an adjustable attenuation range of 0-63 dB in 1 dB steps.

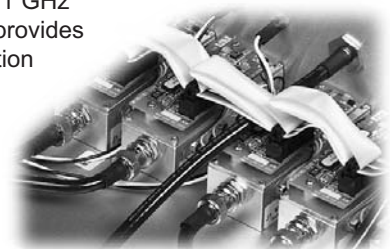

Subsystems & Accessories



Attenuation Matrices & Multi-Channel Subsystems:



Whether the application is an individual attenuation module for satellites or complex matrix/channel configurations for cellular base station testing and operation, Aeroflex / Weinschel's design approach offers a versatile but simple method of creating and packaging fixed, solid-state and/or mechanical (relay) attenuators into customer specified modules and subsystems.

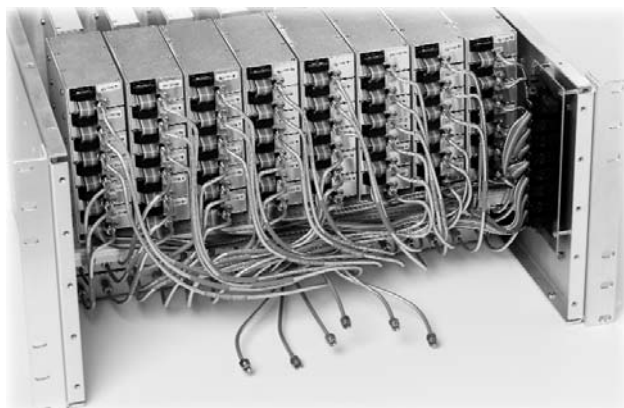

Advanced attenuation/switching schemes using other components such as switches, combiners/ dividers/splitters and directional couplers have already been designed. Our designers use the advanced intelligent Interface firmware to create virtual devices with attenuation ranges up to 127 dB with resolutions of 0.25 dB that can operate over the dc-26.5 GHz frequency band. Other designs can include:

- /// Complex Matrix/Channel Configurations. Typical configuration include 8x8, 4x8, 2x6, 3x6, 6x6
- /// Custom Mechanical Design & Layout.
- /// IEEE-488, Serial or Ethernet (SNMP option) Interface for computer control.
- /// Wide dynamic range & frequency range options available.
- /// Phase compensated attenuation designs.
- /// Solid-State (GaAs FET & PIN) designs available.
- /// Customer specialized testing and calibration can also be supplied.

Customized Mechanical Packaging & Modular Design:

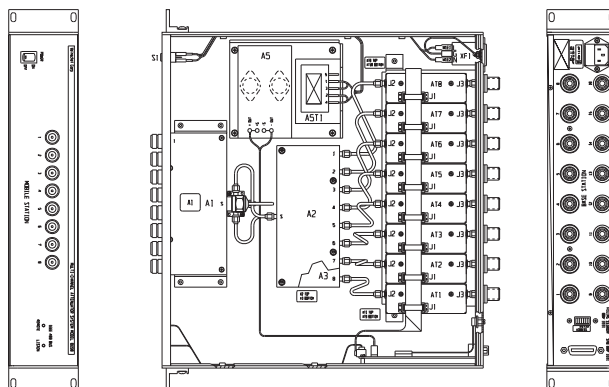

The strength of Aeroflex / Weinschel's subsystem design approach starts with an experienced engineering design staff. Using today's modern design tools and the latest software allows Aeroflex / Weinschel's engineering staff to offer its customers a wide range of customized mechanical packaging & modular design solutions.

Specific PCB and driver configurations can be designed for operating various types of devices or retrofitting an existing device to operate within a subsystem application!

Subsystems are easily configured for mounting into any rack or cabinet designed per EIA RS-310 or MIL-STD-189.

Although Aeroflex / Weinschel specializes in the design of customized module and cabinet configurations, most subsystems are designed using off-the-shelf components, devices and cabinet configurations which allows Aeroflex / Weinschel to design and manufacture subsystems with reduced lead times as well as lower overall design cost.



Low Intermodulation Subsystems & Signal Conditioning Networks...

Some custom subsystem designs warrant the use of Low Intermodulation passive components such as programmable attenuators, terminations, fixed attenuators, couplers, cables, connectors and switches. Aeroflex / Weinschel is a leading manufacturer of the first three items. The following paragraphs briefly describe the importance of low intermodulation and some design features and comparative test data for the same.

Programmable Attenuators

Historically the most demanding specifications for programmable components and subsystems have been low insertion loss and SWR, combined with a reasonable life expectancy of several million switching cycles. This was usually adequate for RF instruments like spectrum analyzers and signal generators, where the attenuator bandwidth rather than the switching speed was of prime concern. To achieve wide bandwidths, the programmable attenuators were mostly of electromechanical design and the linearity of these passive components was only taken for granted. Intermodulation distortion discussions and problems were usually limited to components such as amplifiers, mixers and filters.

In recent years, however, wireless communication systems employing complex digital modulation schemes, increased channel capacity, high transmit power and extremely low receiver sensitivity have put into question the linearity of passive components. Even very low level multi-tone intermodulation products generated by attenuators can seriously degrade the efficiency of a system/instrument if these products fall within the user passband. For two closely spaced tones at frequencies f_1 and f_2 , the third order IM products at $2f_1 - f_2$ and $2f_2 - f_1$, are the most harmful distortion products. They are harmful because they are close to f_1 and f_2 and virtually impossible to filter out.

In today's base stations the multi-carrier power amplifier (MCPA) is replacing banks of single-channel amplifiers and their corresponding power combining network. MCPAs have the capability of carrying a number of modulation schemes simultaneously and can also employ schemes such as dynamic channel allocation (DCA) to use the allocated frequency spectrum more efficiently. The in-band intermodulation distortion (IMD) performance of these amplifiers is extremely critical and needs to be measured using low distortion programmable multi-tone generators with superior IMD performance.

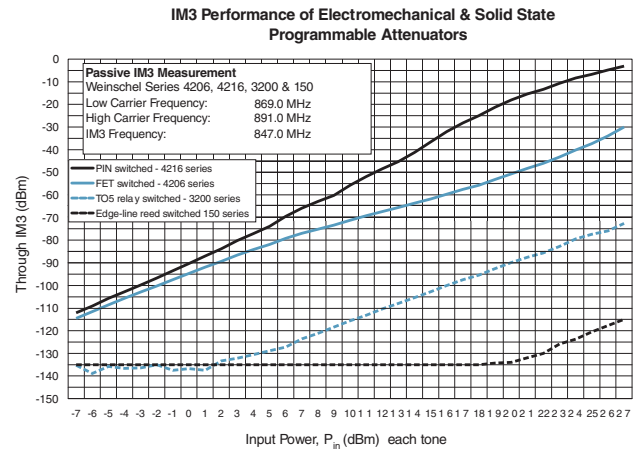

Electromechanical programmable attenuators obviously provide a far superior IMD performance than their corresponding solid state counterparts employing semiconductor switching elements. However, their slow switch speed, in the order of milli-seconds, and short switch life in the order of 5-10 million cycles make them unattractive in some applications like cell phone testing and other ATE systems. Solid State programmable attenuators do overcome these two problems and are, therefore, included here for IMD performance comparison. The goal is to provide some good basic IMD test data for a variety of commercial programmable attenuators and permit the end user to select the most appropriate type for his system application.

Fixed Attenuators & Terminations

These seemingly linear components generate low levels of IMD which must be considered, especially when incident power levels are high. Some of Aeroflex / Weinschel custom subsystem designs include low IM versions of medium and high power fixed attenuators and terminations. These components are supplied with specified 3rd order through and reflected intermodulation levels (IM3) measured with a passive IM analyzer. Typically, the IM3 levels for these components are -110 dBc. Standard Models with this LIM (low IM) option are models 33, 24, 49, 53, 57, 58 and the corresponding terminations, ranging in incident power ratings of 25 to 500 Watts. Features of these components include specifically designed connectors and carefully processed and trimmed thin film resistors for low IM performance.

Couplers, Cables, Switches, Connectors, etc.

For these other passive components Aeroflex / Weinschel works very closely with our suppliers, providing them pertinent design input to achieve the lowest possible IMD performance on such products.

General Information & Indexes



US Sales Representatives....

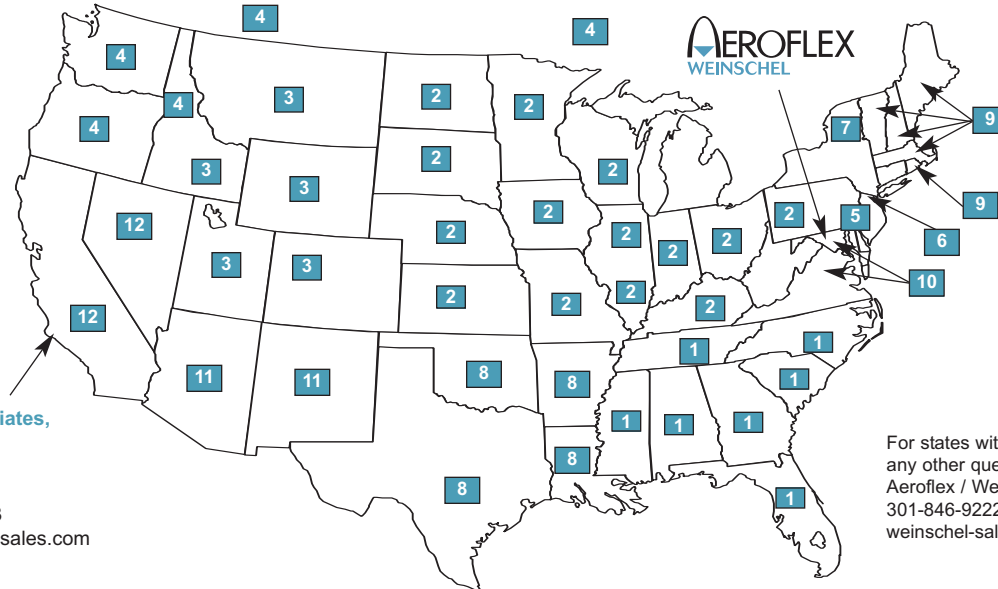

McNamara Associates,
5936 Busch Drive,
Malibu, CA 90265,
Tel: 310-428-5715
Fax: 424-644-8043
email: gary@gmacsales.com

For states with no listing or
any other questions contact
Aeroflex / Weinschel @
301-846-9222 or 800-638-2048
weinschel-sales@aeroflex.com

1. BRENNAN ASSOCIATES: 1428-A Gulf to Bay Blvd., Clearwater, FL 33755, Tel: 727-446-5006, Fax: 407-239-6229, sales@brennanassoc.net

5789 N. Apopka-Vineland Road, Orlando, FL 32818, Tel: 407-239-4399, Fax: 407-294-4906, Mike@brennanassoc.net, www.brennanassoc.net
2090 Vicarage Lane, Snellville, GA 30078, Tel: 770-736-4199, Fax: 407-294-4906, gary@brennanassoc.net

906 Retriever Ave., Seffner, FL 33584, Tel: 727-446-5006, Fax: 407-294-4906, jody@brennanassoc.net

2. CAIN-FORLAW, CO.: 510 N. Plum Grove Road, Palatine, IL 60067, Tel: 847-202-9898, Fax: 847-202-9896, rick.lapiana@cain-forlaw.com, www.cain-forlaw.com

4660 W. Jefferson, Suite 130, Fort Wayne, IN 46804, Tel: 260-436-4466, Fax: 260-436-8995, lee.klaus@cain-forlaw.com

3343 Southgate Court SW, Suite 213, Cedar Rapids, IA 52404, Tel: 319-286-9898, Fax: 319-286-9899, mark.roskopf@cain-forlaw.com

7323 E. Main Street, Suite B, Reynoldsburg, OH, 43068, Tel: 614-861-9500, Fax: 614-861-8510 tom.nelms@cain-forlaw.com

201 W. Travelers Trail, Suite 20, Burnsville, MN 55337, Tel: 952-882-4090, Fax: 952-882-4088, tom.ottoson@cain-forlaw.com

3. CAIN-POLLACK, CO.: 86 E. Estack Place, Highlands Ranch, CO 80126, Tel: 303/805-2515, Fax: 303/805-2514, s.m.pollock@world-net.att.net

4. CAIN-SWEET CO.: 13401 Bel-Red Road Ste. A5, Bellevue, WA 98005, Tel: 425-562-6028, Fax: 425-562-2680, sales@cainsweet.com, www.cainsweet.com

Express: ARGOSY COMPONENT SALES: Toll Free: (800) 575-0962 or (800) 542-4457, Toll-Free Fax: (866) 562-2271, Tel: (425) 562-6112, Fax: (425) 562-2271, sales@argosysales.com, www.argosysales.com

5. EASTERN INSTRUMENTATION OF PHILADELPHIA: 710 E. Main Street, Moorestown, NJ 08057, Tel: 856-231-0668, Fax: 856-231-9022, jerry@eiphila.com, www.eiphila.com

6. SPECTRUM SALES: 40 Underhill Blvd. 2-D, Syosset, NY 11791, Tel: 516-921-5750, Fax: 516-921-5776, sales@spectrumsales.com, www.spectrumsales.com

7. NORTHERN TECHNICAL SALES: 30 Grove Street, Pittsford, NY 14534, Tel: 585-385-6480, Fax: 585-385-7546, bfox@ntsny.com, www.ntsny.com

8. PHASECOM: 99 Trophy Club Drive, Trophy Club, TX 76262, Tel: 817-410-5790, Fax: 817-410-5791, csangalli@phasecom.com, www.phasecom.com

9. dBm TECHNICAL SALES: One Olde North Road, Chelmsford, MA 01824, TEL: 978-256-7100, Fax: 978-256-9705,

10. R. L. ENGINEERING INC.: 3752 Farmland Drive, Fairfax, VA 22033, Tel: 703-819-9498, Fax: 703-865-8335, bobrle@gmail.com

11. TECHNICAL MARKETING SPECIALISTS: 7860 E. Berry Place, Suite 110, Greenwood Village, CO 80111, 303-488-0220, Toll Free: 800-342-8408, Fax: 303-488-0080, cbadzik@tmssales.com, www.tmssales.com

455 S 48th Street, Suite 108, Tempe, AZ 85281, Tel: 480-929-0009, Fax: 480-929-0008

12. WARD / DAVIS ASSOCIATES, NORTH: 2025 Gateway Place, Suite 360, San Jose, CA 95110, Tel: 408-213-1090, Fax: 408-213-1091, norcalsales@warddavis.com, www.warddavis.com

WARD / DAVIS ASSOCIATES, SOUTH: 2623 Manhattan Beach Blvd., Redondo Beach, CA 90278-9981, Tel: 310-643-6977, Fax: 310-643-6035, sales@warddavis.com

For up-to-date sales, distributor listing and information, visit our website at www.aeroflex.com/weinschel-reps.cfm

Worldwide Sales Representatives...

ARGENTINA: DTA SA, Monseñor Pablo Cabrera 5020 , CP X5008HJP - B° Maquez de Sobremonte, Argentina, Tel: 54 351 476 0069, Fax: 54 351 476 4576, jberti@dt-sa.com, www.dta-sa.com

AUSTRALIA: VICOM Australia Pty. Limited, Melbourne Head Office: Sales, Service & Calibration, 1064 Centre Road, VICTORIA, 3167, Tel: (61) 3 9563 7844, Fax:(61) 3 9579 7255, info@vicom.com.au, www.vicom.com.au

Sydney: Sales, Service & Calibration, Silverwater Central, Level 477-79, Parramatta Road, SILVERWATER, N.S.W., 2128, Tel:(61) 2 9648 4757, Fax: (61) 2 9648 4959

AUSTRIA: MRC Components OHG, Obere Dombverggasse 1, D-85354 Freising, Germany, Tel: (49) 8161-9848-0, Fax:(49)8161-9848-20, weinschel@mrccomponents.com, www.mrccomponents.com

BELGIUM: Heynen B.V., Centrum - Zuid 3047, Houthalen (B), 3530

Belgium, Tel:(32)11-600 909 Fax: (32)11-525 777, heynen@heynen.com, www.heynen.com

BOTSWANA: Measuretest CC, 47 Elephant Road, Monument Park, Pretoria, P.O.Box 23829, Republic of, 0150, South Africa, Tel: (27)12 452 040, Fax: (27)12 452 0415, sales@measuretest.co.za, www.measuretest.co.za

BRAZIL: Boreal Communications, Rua Helder Reis Junior 137, 13106-056, Campinas S.P., Tel: 55-19-3258-2210, Fax: 55-19-3258-5109, lduque@borealtec.com.br

BULGARIA: Amtest-TM s.r.o., Svatováclavská 408, Uherské Hradite, 686 01 Czech Republic, Tel: 420-572-572-028, Fax: 420-572-544-216, Roman.Honig@amtest.com, www.amtest-tm.com

CANADA - EASTERN REGION: Cain-Sweet, Co., PO Box 1085, Uxbridge Ontario, L9P 1N4, CANADA, Phone: 416-219-0376, ian@cainsweet.com, www.cainsweet.com

CANADA - WESTERN REGION: Cain-Sweet, Co., Alberta / Saskatchewan Office, Unit 2, 4404-12th Street, N.E., PO Box 82, Calgary, Alberta T2E 6K9, Tel: 403-250-7288, Fax: 403-250-7289, wes@cainsweet.com, www.cainsweet.com

CHILE: Mmwave - Shikatronics S A DE C V, M. Felix Cabrera No. 59, Office 203, Providencia, Santiago, Chile, Tel: (56)2-231-1454 Fax: (56)2-231-2782

CROATIA & CZECH REPUBLIC: Amtest-TM s.r.o., Svatováclavská 408, Uherské Hradite, 686 01, Czech Republic, Tel: 420-572-572-028, Fax: 420-572-544-216, Roman.Honig@amtest.com, www.amtest-tm.com

DENMARK: Compomill Nordic Components AB, Vesterlundvej 6, Den-2730 Herlev, Denmark, Tel: (45) 4484 8700, Fax: (45) 4484 0069, info@compomill.se, www.compomill.se

ENGLAND: Sematron U.K. Ltd., Sandpiper House, Aviary Court, Wade Road, Basingstoke, Hampshire, RG24 8GX, Tel:(44)1256-812222, Fax:(44)1256-812666, sales@sematron.com, www.sematron.com

FINLAND: Compomill Nordic Components AB, Riihitontuntie 2, FIN-02200 Espoo, 358, FINLAND, Tel: 9 524 470358, Fax: 9 524 471, info@compomill.se, www.compomill.se

FRANCE: ACAL BFI France S.A.S, 4, Allée du Cantal , Z.I. La petite Montagne Sud, C E 1834, Evry, 91018, FRANCE, Tel: +33.1.60.79.89.22, Fax: 33.1.60.79.89.01, sales@bfioptilas.com, www.bfioptilas.com

GREECE: American Technical Enterprises, S. Aagou Konstantinou 39, Athens, Greece, Tel: (30) 210-524-0740, Fax: (30) 210-524-9995, ate2000@otenet.gr, www.amtest-tm.com

GERMANY: MRC Components OHG, Obere Dombverggasse 1, D-85354 Freising, Germany, Tel: (49)8161-9848-0, Fax: (49)8161-9848-20, weinschel@mrccomponents.com, www.mrccomponents.com

HUNGARY: Amtest-TM Kft.Jozsef u. 29., Budapest, H-1184, HUNGARY, Tel: (36) 1 294 2785, Fax: (36) 1 294 2785, Tibor.Csombordi@amtest-tm.com, www.amtest-tm.com

INDIA: Bryka Electrosystems & Software Pvt. Ltd., 201, Marine Chambers, 11, New Marine Lines, V. Thackersey Marg, Mumbai 400 020, India, Tel: (91) 22 22074891, Fax: (91)22 22002225, sales@bryka.net, www.bryka.net
New Jersey Office: Bryka LLC, 4400 Rte 9 S, Suite 1000, Freehold, NJ 07728, Tel: 732-851-9034, Fax: 732-810-0432

INDONESIA: P.T. TME, BLK 3014 A , UBI Road 1, #05-12, 408703, SINGAPORE, Tel: (65)747-7234, Fax: (65)747-7132, tmesys@singnet.com.sg, www.tmesystems.com.sg

ISRAEL: Ormic Components Ltd.: 2a Habarzel St., Tel- Aviv, 69710, ISRAEL Tel: 972-3-7657290, Fax: 972-3-5488660, ronm@ormic.co.il, www.ormic.co.il

ITALY: SEMATRON ITALIA S.R.L.Viale Marx 153/2 - 00137, Roma, ITALY, Tel: 3906-8689-5015, Fax: 3906-8680-2253, sales@sematronitalia.eu, www.sematronitalia.eu

JAPAN: Cornes Technologies Limited, Cornes House, 5-1 Shiba 3-chrome, Minato-ku, TOKYO, 105-0014. JAPAN, Tel: (81) 3-5427 -7550, Fax: (81) 3-5427-7570, sales@cornestech.co.jp, www.cornestech.co.jp

LESOTHO: Measuretest CC, 47 Elephant Road, Monument Park, Pretoria, P.O.Box 23829, Republic of, 0150, South Africa, Tel: (27)12 452 040, Fax: (27)12 452 0415, sales@measuretest.co.za, www.measuretest.co.za

LUXEMBOURG: HEYNEN, B.V.Centrum - Zuid 3047, Houthalen (B), 3530, Tel:(32)11-600 909 Fax: (32)11-525 777, heynen@heynen.com, www.heynen.com

MOZAMBIQUE & NAMIBIA: Measuretest CC, 47 Elephant Road, Monument Park, Pretoria, P.O.Box 23829, Republic of, 0150, South Africa, Tel: (27)12 452 040, Fax: (27)12 452 0415, sales@measuretest.co.za, www.measuretest.co.za

MALAYSIA: Test Measurement & Engineering, Sdn., Lot 14 Level G Hotel Equatorial, 1 Jalan Bukit Jambul, 11900 Bayan Lepas, Penang,Tel: (60) 4-642-2088, Fax (60) 4-644-1883, tmeppg@tm.net.my, www.tmesystems.com.sg

NETHERLANDS: Heynen B.V.De Groote Heeze 11n L 6598 A V Heijnen, Gennep, 6590 A A, NETHERLANDS, Tel: (31)485-550 909, Fax:(31)485-550 900, heynen@heynen.nl, www.heynen.com

NEW ZEALAND: VICOM Australia Pty., Limited, Auckland Sales, Lower Ground Floor, 60 Grafton Road, AUCKLAND, NEW ZEALAND, Tel: (64) 9 379 4596, Fax:(64) 9 379 4597, info@vicom.com.nz, www.vicom.com.au

NORWAY: Compomill Nordic Components AB, Dragonvägen 42, VASBY, SWEDEN, Tel:(46)8-594 111 50, Fax:(46)8-594 211 60, info@compomill.se, www.compomill.se

PEOPLES REPUBLIC OF CHINA: Corad Technology Ltd., Unit 1306, Nanyang Plaza , 57 Hung To Road, Kwun Tong, Kowloon, Hong Kong, P R C Tel: (852)2793-0330, Fax: (852)2793-0606, info@tnm-corad.com, www.corad.com

POLAND: Amtest PL, UL Chojnicka 57 - 1, Poznan, 60-480, POLAND, Tel: (48)618 428 171(48)618 428 171amtestpl@wp.plwww.amtest-tm.com

PORTUGAL: BFI OPTILAS SPAIN, Anabel Segura 7 - Planta Baja, Madrid, SPAIN, Tel: (34)91 453.11.60, Fax:(34)91 662.68.37, Africa.Fernandez@bfioptilas.com, www.bfioptilas.com

PORTUGAL: BFI Optilas Spain, Anabel Segura 7 - Planta Baja, Madrid, SPAIN, Tel: (34)91 453.11.60, Fax:(34)91 662.68.37, Africa.Fernandez@bfioptilas.com, www.bfioptilas.com

RUMANIA: mtest-TM s.r.o., Svatováclavská 408, Uherské Hradite, 686 01, Czech Republic, Tel: 420-572-572-028, Fax: 420-572-544-216, Roman.Honig@amtest.com, www.amtest-tm.com

RUSSIA, SLOVENIA: Amtest-TM, s.r.o. Kosiky 40, Traplice, 687 04, Czech Republic, Tel:(42)0 572 572 358, Fax: (42)0 572 572 358, Roman.Honig@amtest.com, www.amtest-tm.com

SAUDI ARABIA: EEMCO, 104 Fahada Center, Tahliya, Riyadh 11481, tel: (966) 1-279-2537 fax (966) 1-279-2536, eemco@nesma.net.sa

SINGAPORE, INDONESIA: TME SYSTEMS PTE., LTD.Blk2 Kaki Bukit Avenue 1#05-06 417938, Tel:(65) 6747 7234, Fax:(65) 6747 7132, tme@tmesystems.com.sg, www.tme.com

SOUTH AFRICA, SWAZILAND, ZAMBIA, ZIMBABWE: MEASURETEST, CC, 47 Elephant Road, Monument Park, Pretoria, P.O.Box 23829, REPUBLIC OF South Africa, 0150, Tel: (27)12 452 0400, Fax:(27)12 452 0415, sales@measuretest.co.za, www.measuretest.co.za

SOUTH KOREA: Chang Woo Inc., Keum Young Bldg.15-11 Yeoeuido-Dong, Youngdeungpo-Gu, Seoul 150-872, Korea, Tel: (82)2-782-9056, Fax: (82)2-782-9058, salescwinc@hananet.net, www.changwooinc.com

SPAIN: BFI Optilas Spain, Anabel Segura 7 - Planta Baja, Madrid, SPAIN, Tel: (34)91 453.11.60, Fax:(34)91 662.68.37, Africa.Fernandez@bfioptilas.com, www.bfioptilas.com

SWEDEN: Compomill Nordic Components AB, Dragonvägen 42, VASBY, SWEDEN, Tel:(46)8-594 111 50, Fax:(46)8-594 211 60, info@compomill.se, www.compomill.se

SWITZERLAND: MRC Components OHG, Obere Dombverggasse 7, D-85354 Freising, Germany, Tel:(49)8161-9848-0, Fax:(49)8161-9848-20, weinschel@mrccomponents.com, www.mrccomponents.com

TAIWAN: EAGLETEK CORPORATION, 10F-1, No. 190, Sec 2, Chung-Hsing Rd, Hsintien, Taipei 231, TAIWAN, Tel: (886) 2-8911-0413, Fax: (886)2-8911-1572, leochang@eagletek.com.tw, www.eagletek.com.tw

THAILAND: Aerocomm Company Ltd.89 & 89\1 Intamara 41 Sutthisarn Rd.Dindang, Bangkok, 10400, Thailand, Tel: 66)2-693-8300, Fax: (66)2-693-8304, aerocomm@aerocommthailand.com, www.aerocommthailand.com

YUGOSLAVIA: Amtest-TM, s.r.o. Kosiky 40, Traplice, 687 04, Czech Republic, Tel:(42)0 572 572 358, Fax: (42)0 572 572 358, Roman.Honig@amtest.com, www.amtest-tm.com

NOTE: For Countries NOT listed contact the Sales Department at Aeroflex / Weinschel @ weinschel-sales@aeroflex.com or 301-846-9222.

General Information & Indexes



Ordering & Service Information...

HOW TO ORDER: Please order by both catalog model number and description of the component to avoid any misunderstanding (e.g., Model 1506A Broadband Coaxial Power Divider). Special features and modifications not listed in the specifications may be available at extra cost. Please contact the factory regarding any nonstandard features.

WHERE TO ORDER: Address all purchase orders and other communications to:

Aeroflex / Weinschel, Inc.
5305 Spectrum Drive Frederick, MD 21703-7362
Phone #: 301-846-9222
Fax: 301-846-9116
email: weinschel-sales@aeroflex.com
Toll Free: 800-638-2048
Express: 800-542-4457 (Argosy Sales)

or contact your nearest Aeroflex / Weinschel Sales Representative.

Purchase orders will be accepted via phone, fax or email pending confirmation of your standard purchase order form. Determination of prices, terms and conditions of sale and final acceptance of orders are made only at Aeroflex / Weinschel.

DOMESTIC TERMS: Formal price quotations remain in effect for 60 days. Terms of payment are net 30 days for established accounts; new accounts are also net 30 days subject to credit approval. Aeroflex / Weinschel also accepts AMEX, VISA and Mastercard. If credit has not been established, payment must be received before shipment or shipment will be made C.O.D. to avoid delay. All prices are F.O.B. Frederick, Maryland and include commercial inspection and packing for shipment within the continental United States.

EXPORT TERMS: Export prices including the cost of packing are available from Aeroflex / Weinschel or from the export representatives. On orders placed directly with Aeroflex / Weinschel, payment terms are Cash in Advance or by major credit card. Irrevocable Letter of Credit through a U.S. Bank against presentation of our draft and corresponding documents will be accepted for orders valued at \$5,000 minimum. All prices are F.O.B. Frederick, Maryland.

SHIPPING INSTRUCTIONS: Unless specific instructions accompany the order, we shall use our judgment as to the best method of shipment. Shipments can be made by either air or surface transportation.

MINIMUM ORDER VALUE: Purchase orders amounting to \$500.00 net or less, will be billed at \$500.00 plus shipping costs.

SOURCE INSPECTION SURCHARGE: If customer or Government Source inspection is required, add \$350.00 or 5% of the purchase order value, whichever is greater.

CERTIFICATE OF COMPLIANCE: A Certificate of Compliance is shipped with every order along with the packing slip. Extra copies are available upon request at any time. The certificate states:

Aeroflex / Weinschel certifies that all items/materials are inspected and tested as applicable, and are in accordance with the purchase agreement, drawings, OEM specifications, and other applicable documentation. Calibration and equipment standards as applicable are traceable to the National Institute of Standards and Technology. Supporting documentation is on file at this facility.

WARRANTY: Aeroflex / Weinschel warrants each product it manufactures to be free from defects in material and workmanship under normal use and service anywhere in the world. Weinschel's only obligation under this Warranty is to repair or replace, at its plant, any product or part thereof that is returned with transportation charges prepaid to Aeroflex / Weinschel by the original purchaser within ONE YEAR from the date of shipment.

The foregoing Warranty does not apply to, and in Aeroflex / Weinschel's sole opinion, products that have been subject to improper or inadequate maintenance, unauthorized modifications, misuse, or operation outside the environmental specifications for the product.

Aeroflex / Weinschel software products are supplied without representation or Warranty of any kind. Aeroflex / Weinschel, therefore, assumes no responsibility and will not accept liability (consequential or otherwise) arising from the use of program materials, disk, or tape.

IN-WARRANTY REPAIRS: When returning a component back to our factory, a Return Materials Authorization (RMA) number must be obtained from Aeroflex / Weinschel. When contacting us for an RMA number, please indicate the model number, serial number, and date of the original purchase order. Also include as much information as possible pertaining to nature of the malfunction or reason for return. The items returned should be accompanied with this information and include your company name, your name, and a phone number where you can be reached.

OUT-OF-WARRANTY REPAIR: Should it become necessary to return a component for repair, follow the procedure described in the preceding paragraph prior to shipping. Within one week after receipt at the factory, the unit will be evaluated and a formal quotation will be supplied. Repair will begin when authorization is received in the form of a Purchase Order. Weinschel gives a 90-day warranty on all out-of-warranty repairs.

CANCELLATION AND RETURNS: Orders placed with Aeroflex / Weinschel may be cancelled only after authorization by Weinschel. Any authorized cancellation is subject to cancellation charges as determined by Weinschel. A component returned for credit will be subject to a restocking charge. If more than 6 months has elapsed since original purchase, the item may not be accepted for credit. Nonstandard components cannot be returned for credit.

TEST & SERVICE: Aeroflex / Weinschel is committed to providing fast, professional customer service and support worldwide. You have the assurance of knowing our staff of highly trained professionals is available using approved procedures and instrumentation. Aeroflex / Weinschel Test and Service is always committed to quality as defined by the customer. Full lines of repair and test services are available.

Aeroflex / Weinschel does not provide calibration for any product or provide Certificates of Calibration in accordance with the requirements of Mil-Std 45662, ISO 9001, ISO 9002, ISO 10012-1, ANSI/NCSL-Z540, or ANSI/ISO/IEC 17025-2000 requirements. Aeroflex / Weinschel will assist our customers as following in obtaining Calibration of Product in accordance with the requirements of Mil-Std 45662, ISO 9001, ISO 9002, ISO 10012-1, ANSI/NCSL-Z540, or ANSI/ISO/IEC 17025-2000.

Aeroflex / Weinschel will provide Certificates of Conformance, Certificates of Test and Test Data Reports for products as required or as requested by a customer. These forms state that product has been tested to published specifications using equipment whose accuracies are traceable to the National Institute of Standards and Technology (NIST).

Test Data: Special and/or additional test data is available at a nominal charge.

Repair work: Accomplished repairs will return the item to its published specification. Aeroflex / Weinschel provides a 90-day warranty on repair services performed, with fixed price repairs on most products.

Telephone/E-mail Consultations: Our test and Service Department will gladly provide informal consultation over the telephone or through e-mail (service@weinschel.com) with testing and or service questions.

Alphabetical Index...

A dapters, Coaxial	177-184	2.92mm (SMK)	201, 233-234
Frequency Asked Questions	179	3.5mm	201, 224-232
General Information	177	Digital & MMIC	235-240, 247
High Performance Coaxial Adapter, N to SMA	183	General Information	199
Index, Precision Adapters (dc-26.5 GHz)	178	Frequently Ask Questions	203-205
OEM Precision Coaxial Panel Mount, SMA	180	Ethernet Control	248-253
Precision N to N	182	GaAS Switched	202,243-246, 252-254
Precision N to SMA	184	High Power, Hot Switching	255-257
Precision SMA to SMA	181	Index, Relay Switched, Basic Models, dc-6 GHz	200
Aeroflex / Weinschel	2-3	Index, Relay Switched w/built-in Microprocessor	200
Amplifier / Switch Units	268-270	Driver, dc-6 GHz	
Attenuation Matrices	263	Index, Relay Switched, Basic Models, dc-40 GHz	201
Attenuators, Variable (Step & Continuous)	133-150	Index, Relay Switched w/built-in Microprocessor	201
General Information	133	Driver, dc-26.5 GHz	
Frequency Asked Questions	135	Index, Solid-State & Digital	202
Index, Continuous Variable, dc-4.2 GHz	134	Intermodulation Distortion in Programmable	
Index, Manual Step Attenuators, dc-26.5 GHz	134	Attenuators	206-208
Manual Step, 2.92mm (SMK)	149-150	N	203, 248-257
Manual Step, N	146-148	Pin Switched	202, 241-242, 247, 252-254
Manual Step, RF	138	Programmable Attenuator Units	248-257
Manual Step, SMA	143-145	Relay Switched	209-223, 252-254
Precision Continuous Variable, N & SMA	136-137	RS-232 Control	209-223, 252-254
Attenuators, Coaxial Fixed	15-80	Solid-State	235-248, 252-254
2.4mm	32	SMA	200, 202, 209-232, 252-254
2.92mm (SMK)	31, 33, 39, 43, 44, 48, 49, 51, 55, 58, 59,	USB Control	239-240, 252-254
.....	62, 63, 73, 76-80		
3.5mm	30, 40, 52, 53, 56, 57, 60, 61, 66	B lind-Mate Connectors	185-194
7/16	50, 54, 64	2.92mm	186, 188-194
Bi-Directional	45, 49, 51, 52, 55, 56, 67, 73-75	Applications	187
Conductive Cooled	20, 65, 70, 71, 73-80	Attenuators, Example	192
Convection Cooled	45-72	Custom Examples	192-194
Forced Cooled	69	Description	185
Frequently Ask Questions	21-22	Features	185
General Information	15	Front Locking	186, 190
General Purpose	28, 34	General Information	187
Hex Body	29	Index, Blind-Mate Connectors	186
High Power	58-80	Frequency Asked Questions	179
High Reliability & Space	12, 41	Microstrip, Example	192
Index, Conduction Cooled, dc-40 GHz, 5-550 Watts	20	Pressurized	188
Index, Medium Power, dc-40 GHz, 10-50 Watts	17	Rear Locking	189, 191
Index, High Power, dc-18 GHz, 100-1,000 Watts	18	SMA	192-193
Index, High Reliability & Space, dc-40 GHz, 2 Watts	16	C onnectors, Blind-Mate	185-194
Index, Low Power, dc-40 GHz, 1-5 Watts	16	Connectors, Planar Crown	195-198
Index, Low IM, dc-26.5 GHz, 25-550 Watts	19	Complex Multi-Channel Attenuator	262, 277
Lab Standard	37	D C Blocks	171-176
Low IM	19, 50-52, 54-56, 60,62, 64, 65, 68, 70	General Information	171
Low Power, dc-40 GHz, 1-5 Watts	16, 26-444, 42-44, 73	Index, dc Blocks, dc to 18 GHz	171
Medium Power, dc-40 GHz, 10-50 Watts	17, 45-57	Inside	171-175
N	34, 36, 37, 40-41, 46, 47, 49, 51, 52, 55-72, 74, 76-80	Inside/Outside	176
Precision Sets	40	Planar Bulkhead	175
Selection Matrix	23	N	172
SMA	26-29, 38, 41, 42, 45	SMA	173-176
TNC	35	Directions to Weinschel	288
Understanding Temperature & Power	24-25	Dividers, Power	151-164
Coefficient in Attenuators		E xpress Overnight Shipment Service	9-11
Attenuator / Switch Units	267-268	F ixed Coaxial Attenuators	15-80
Attenuator/Switch Controllers	203, 216, 225, 258-260	H igh Power Programmable Attenuator	255-257
Attenuator, Manual Step	133-135, 138-150	High Power Programmable Switch	271-272
2.92mm	149-150	L ow Intermodulation Subsystems & Signal	280
General Information	133	Conditioning Networks	
Frequency Asked Questions	135	M anual Step Attenuators	133-150
Index, Manual Step Attenuators, dc-26.5 GHz	134	Mobile Unit Fading Simulators	262, 276
N	136, 146	Model Number Index	4-6
RF	138	O pen / Short / Load	82, 132
SMA	138-148	Ordering & Service Information	285
Attenuators, Programmable	199		

Phase Shifters	165-170	Switch Matrices & RF Distribution Systems	264
2.92mm (SMK)	166, 169	Subsystem Product Overview	262
3.5mm	166, 170	WLAN Roaming Simulator	265-266
General Information	165	Splitters, Power	152, 154-158
Index, dc to 20 GHz	166	Solid-State & Digital Attenuators	235-247, 252-254
SMA	166-168	Switch Matrices & RF Distribution Systems	264
Miniature In-Line	169	T able of Contents	1
Planar Crown Connector System	195-198	Terminations & Loads	81-132
Pin Switched Programmables	241-242, 247, 252-254	2.4mm	82, 96
Power Splitters & Dividers	151-164	2.92mm (SMK)	82-87, 95, 99, 104, 106, 111, 114, 117-119, 121, 125, 126, 128-131
2.92mm (SMK)	154, 158, 163	3.5mm	82-85, 94, 107, 108, 112, 113, 116, 117, 127
3.5mm	155, 157, 162	7/16	105, 110, 120
4-Way	164	BNC	109
Dividers	151, 152, 159-164	Conduction Cooled	119, 121, 125-132
Frequently Ask Questions	153	Convection Cooled	85, 86, 111-124
General Information	151	Frequently Ask Questions	88-89
Index, Splitters	151-158	General Information	81
Index, Dividers	152	General Purpose	93
N	156, 161	High Power	84
Splitters, Matching	154-156	Index, High Power, dc-18 GHz, 100-1,000 Watts	84
SMA	152, 159, 160	Index, Low Power, dc-50 GHz, 1-5 Watts	82
Product Index	6-8	Index, Medium Power, dc-26.5 GHz, 10-50 Watts	83
Programmable Attenuators	199-257	Index, Low IM, dc-18 GHz, 25-550 Watts	85
R elay Switched Programmable Attenuators	199-201, 209-234	Lab Standard	91
RoHS Compliance	286	Low IM Options	85, 105-107, 110, 112, 117, 119-123
S ubsystems & Accessories	261-282	Low Power	83, 90-99
Application Specific Subsystems	278-279	Medium Power	82, 100-113
Attenuation Matrices	263	N	83-87, 91, 93, 97, 101-104, 106, 107, 109, 111-119, 121-124, 126, 128-131
Amplifier / Switch Units	269-270	Open / Short / Load	86, 132
Cellular & Wireless Test Solutions	273	Section Guide	87
Complex Multichannel Attenuator	277	SMA	82-83, 90, 92, 98, 100, 109
Custom Mechanical Packaging & Modular Design	279	Subminiature	92, 98
General Information	261	TNC	132
High Power Programmable Switch	271-272	U S Sales Representatives	283
L-Band 8X8 Switch Matrix	274-275	W LAN Roaming Simulator	265-266
Low Intermodulation Subsystems & Signal Conditioning Networks	280	Worldwide Sales Representatives	284
Mobile Unit Fading Simulators	276		
Programmable Attenuator / Switch Unit	267-268		

RoHS

Statement of Compliance on Directive 2002/95/EC of the European Parliament and of the Council on the restriction of the use of certain hazardous substances in electrical and electronic equipment (RoHS)

Aeroflex / Weinschel products are classified as Monitoring and Control Equipment (Category 9 of the WEEE Directive, which includes measuring, weighing, or adjusting appliances for household or as laboratory equipment) which is excluded from the RoHS Directive. However, Aeroflex / Weinschel is in the process of evaluating materials and processes to achieve RoHS compliance while maintaining our performance and quality standards.

RoHS compliance of products may be by exemption as stated in the Directive's annex, Point 6 (lead as an alloying element in steel containing up to 0.35% lead by weight, aluminum containing up to 0.4% lead by weight, and as a copper alloy containing up to 4% lead by weight); and/or Point 7 (lead in electronic ceramic parts); and/or Point 8 modified by Commission Decision of 21 October 2005 (Cadmium and its compounds in electrical contacts).

Throughout this catalog products that can be manufactured as RoHS Compliant products will contain the  RoHS symbol located at the upper right corner of the individual data sheet. Please inquire or specify RoHS compliant materials are required when ordering.

Directions to Aeroflex / Weinschel...

FROM DULLES/NATIONAL AIRPORTS: Take Dulles Access Road to Capitol Beltway/Route 495. Continue to exit for Route 270 North toward Frederick, Maryland. Travel approximately 37 miles on Rt 270, and you will get off at Exit 31A--Route 85/North. Proceed to stoplight and turn right into Francis Scott Key Mall entrance. Stay in left lane, going past the mall on right, various restaurants on left (Pargo's, ...Golden Corral--caution just past here for four-way stop signs!--continue past Pizza Hut). You are now on Spectrum Drive; continue on until you see cul-de-sac area with mailboxes on right; bear left into "Spectrum Place." Aeroflex / Weinschel building, 5305, is to the right. Visitor parking in front of building. Or take the SCENIC ROUTE (BACK WAY): Leaving Dulles Airport, watch immediately for the "Dulles Greenway," get on the Greenway and follow it all the way to the end (toll road-pay toll before exiting); The Greenway actually ends at Route 15 North (sign will say Frederick); stay on Route 15N, crossing bridge into Maryland--Rt 15N will merge with Route 340 West; continue on 340W to exit for Route 70 East toward Baltimore.

Coming off exit, you can either:

Stay in right lane of exit ramp, take 270 South to exit 31A (Rt 85 North). Proceed to stop light and turn right into Francis Scott Key Mall entrance. Stay in left lane, going past the mall on right, various restaurants on left (Pargo's, Golden Corral--caution just past here for four-way stop signs!--continue past Pizza Hut and Sleep Inn). You are now on Spectrum Drive; continue on until you see cul-de-sac area with mailboxes on right; bear left into "Spectrum Place." Aeroflex / Weinschel building, 5305, is to the right. Visitor parking in front of building.

NOTE: This is a long 2-lane exit; if it is backed up--and it often is at rush hours--it is better to proceed to next exit as follows.

Come off left lane of exit ramp onto 70E, go ~ one mile to very next Exit 54/Market Street/Rts 355S & 85. At top of exit ramp, turn left at the second traffic light (RT355). Go through next three traffic lights down Rt 355S, continue on past Home Depot...Target... Wickes Lumber on left/large red brick NorWest Mortgage building on right, to the entrance to 270 Tech Park/New Technology Way on right. Follow New Technology Way to STOP sign, turn left on Spectrum Drive and almost immediately--at cul-de-sac--turn left again into "Spectrum Place." Aeroflex / Weinschel building, 5305, is to the right. Visitor parking in front.

NATIONAL: Take George Washington Memorial Parkway North to Beltway/Rte 495. Continue on Rte 495 toward Maryland, then same as above.

FROM BALTIMORE/BWI AIRPORT: Take 195 out of airport, to 95 North (695 Exit)*; get on 95 North and move to far left lane. Exit onto 695 North (towards Catonsville/Towson). Stay on 695N until signs show 70 West/Frederick (~ 8-10 mls). Exit onto 70 West, and stay on 70W for ~ 35 mls; you will get off at Exit 54/Market Street/Rte 355. At top of exit ramp, turn right at the first traffic light and right at the

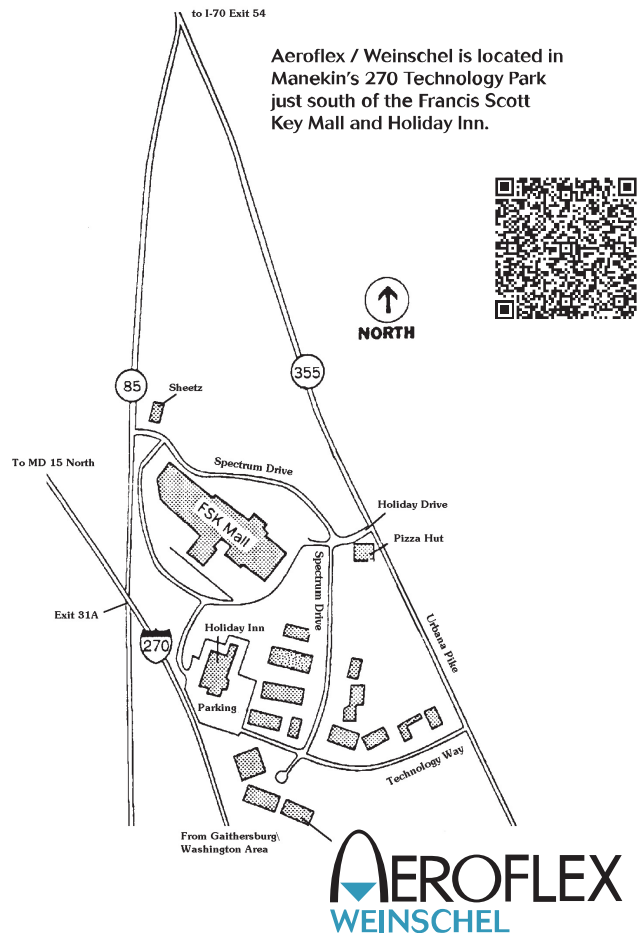

second light and stay in the left lane (RT355). Go through four traffic lights on 355 South, continue ~ 1.5 miles past Home Depot...Target...Wickes Lumber on left/large red brick NorWest Mortgage building on right, to the entrance to 270 Tech Park/New Technology Way on right. Follow New Technology Way to STOP sign, turn left on Spectrum Drive and almost immediately--at cul-de-sac--turn left again into "Spectrum Place." Aeroflex / Weinschel building, 5305, is to the right. Visitor parking in front.

*NOTE: Do not take 95 North (Harbor Tunnel) exit; proceed to second 95 North entrance.

FROM NEW YORK/NEW JERSEY: Take I-95 toward Baltimore; Exit onto Baltimore Beltway, Rt 695 West towards Towson; Exit from the Beltway onto I-70 toward Frederick. You will travel approximately 55 miles and come off at Exit 54 (Market Street)/Rte 355. At top of exit ramp, turn right at the first traffic light and right at the second light and stay in the left lane (RT355). Go through four traffic lights on 355 South, continue ~ 1.5 miles past Home Depot...Target...Wickes Lumber on left/large red brick NorWest Mortgage building on right, to the entrance to 270 Tech Park/New Technology Way on right. Follow New Technology Way to STOP sign, turn left on Spectrum Drive and almost immediately--at cul-de-sac--turn left again into "Spectrum Place." Aeroflex / Weinschel building, 5305, is to the right. Visitor parking in front.



Certificate No. 289j



AEROFLEX / WEINSCHEL

5305 Spectrum Drive
Frederick, MD 21703-7362
Tel: 800-638-2048, 301-846-9222
Express: 800-542-4457 (US & Canada Only)
Order online @ www.argosysales.com (US & Canada Only)
Fax: 301-846-9116
www.aeroflex-weinschel.com
weinschel-sales@aeroflex.com



AEROFLEX
A passion for performance.



Our passion for performance is defined by three attributes represented by these three icons: solution-minded, performance-driven and customer-focused.